

OPERATING MANUAL

**POWER CONTROLLED
WINCHES
W3A and W3.5B**

**THIS MANUAL MUST BE WITH THE VEHICLE
ON WHICH THIS WINCH IS INSTALLED**

Winch Model _____

Serial Number _____

Delivered _____

Installed _____

Special Equipment or Attachments

Allied Systems
COMPANY
WINCH DIVISION



 Trademark under license from Hyster Company

12/95 (6/90) AP Litho in USA

FOREWORD

The safe and efficient operation of a winch requires skill and alertness on the part of the operator. To develop the skill required, the operator must:

- receive training in the proper operation of the winch and the machine on which it is mounted.
- understand the capabilities and limitations of the winch and the machine on which it is mounted.
- become familiar with the winch and the machine on which it is mounted and see that they are maintained in good condition.
- read and understand the WARNINGS and OPERATION PROCEDURES contained in this **Operating Manual**.

In addition, a qualified person experienced in the operation of the winch, must guide a new operator through several load handling applications before the new operator attempts to operate the equipment alone.

It is the employer's responsibility to make sure that the operator can see, hear, and has the physical and mental ability to operate the equipment safely.

This **Operating Manual** contains basic information necessary for the operation and maintenance of a winch. Optional equipment is sometimes installed that can change the characteristics described in this manual. Make sure the necessary instructions are available and understood before operating the winch.

Some of the components described in this Operating Manual will NOT be installed on your winch. If you have questions about any item on your winch or described in this **Operating Manual**, contact your Hyster winch dealer.

NOTE: For repairs and overhaul, contact your Hyster winch dealer. If you maintain your own equipment, a service manual is available for your specific winch.



CONTENTS

FOREWORD	i	OPERATING PROCEDURES	9
CONTENTS	ii	POWER OPERATION	10
WARNING	iv	FREESPOOL OPERATIONS	10
INTRODUCTION	1	FREESPOOL ADJUSTMENT	11
GENERAL	1	CHECKS BEFORE OPERATION	12
How The Winch Operates	1	CHECKS DURING OPERATION	12
Nameplate	3	W3A/W3.5B TROUBLESHOOTING CHART	13
Cable Selection	4	OPERATING TECHNIQUES	14
W3A AND W3.5B WINCH	5	Skidder Or Tractor Operation	14
DESCRIPTION	5	How To Move A Disabled Vehicle	17
Optional Equipment	7	MAINTENANCE	19
		MAINTENANCE SCHEDULE	20
		Control Cable Adjustments	21
		Approved Oil List	23

 **WARNING**

FAILURE TO FOLLOW THESE INSTRUCTIONS CAN CAUSE SERIOUS INJURY OR DEATH

AUTHORIZED, TRAINED OPERATOR ONLY.

KNOW THE EQUIPMENT: Know the operating, inspection, and maintenance instructions in this **Operating Manual**. Do not operate the winch unless the vehicle is equipped with a screen to protect the operator if the cable breaks.

INSPECT THE WINCH BEFORE USE: Make sure that the controls and instruments operate correctly. Report the need for repairs immediately. Do not work with a damaged or worn cable. Do not use a winch that needs repairs. If the cable and ferrule must be removed from the drum, make sure the end of the cable and ferrule are controlled when the ferrule is released. The end of the cable can suddenly move from the drum like a compressed spring when the ferrule is released and cause an injury.

PROTECT YOURSELF: Do not use the control levers for hand holds when entering or leaving the vehicle. Do not permit other people near the control area when you inspect or repair a machine. Never inspect, repair, or do maintenance on a machine that is in motion. Stay in the

operator's seat. Do not stand on the vehicle when operating the winch.

KEEP A CLEAR WORK AREA: Avoid winch operation near people or other machines. Never stand nor permit others to stand in the bight (loop) of a cable. Do not stand nor permit others to be near the winch or cable when there is tension on the cable. Observe jobsite rules. Be in complete control at all times.

USE COMMON SENSE: Do not use the control levers as hangers for clothes, water bags, grease guns, lunch pails, etc. Do not leave the vehicle when the winch cable is under tension. Do not permit riders on the vehicle or load. Do not use the winch as an anchor for a double or two-part line. Do not pull the hook through the throat or over the drum and cause damage. When the winch is not in use, make sure the control lever is in **BRAKE ON** position and the winch brake is applied.

 **WARNING**

Indicates a condition that can cause personal injury!

 **CAUTION**

Indicates a condition that can cause property damage!

INTRODUCTION

GENERAL

This **Operating Manual** is divided into separate sections to describe several models of Hyster winches. Models that have similar operating characteristics are described in the same section.

How The Winch Operates

A winch is normally installed on a skidder or tractor:

- to increase the pulling power of the skidder or tractor
- to reach into an area where a skidder or tractor can not go
- to make lift functions available when special attachments are installed

The winch has hydraulic clutches that are similar to a hydraulic (powershift) transmission. Most tractors and skidders have a power take-off (PTO) that is used to

connect the power from the engine to the winch. The **SCH** (Self Contained Hydraulics) on the winch label indicates that the hydraulic system for control of the winch is inside of the winch case. When the PTO is operating, a hydraulic pump in the winch case takes hydraulic oil from the winch sump and sends it to the hydraulic control valve. The hydraulic control valve controls the operation of the winch. Removable covers on the winch case permit access for repairs and adjustments. The design of the winch cases permit a variation in the arrangements of PTO assemblies to fit the different tractors and skidders that can use these winches.

The PTO is connected to the pinion assembly in the winch. When the pinion rotates, a spur gear turns the hydraulic pump and the pinion turns the ring gear (bevel gear). The bevel gear is connected to an oil clutch for the **LINE IN** (power forward) operation and another oil clutch for the **LINE OUT** (power reverse) direction.

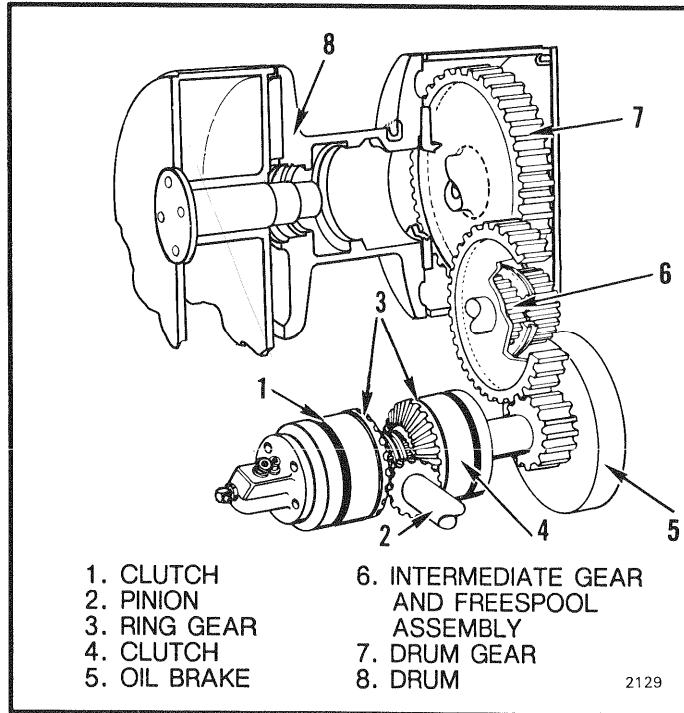

FIGURE 1. WINCH, TYPICAL GEAR TRAIN

The power through the winch to the drum for the cable is controlled by a **LINE IN** and a **LINE OUT** clutch. When the **LINE IN** clutch is applied, the drum rotates to pull the cable into the winch. When the **LINE OUT** clutch is applied, the drum rotates to permit the cable to be pulled from the winch at the speed controlled by the engine rpm.

NOTE: The W3A/W3.5B winch has only a **LINE IN** clutch.

When the control lever is in the **BRAKE ON** position, an oil brake is automatically applied by a spring to hold the drum in its position. If the control lever is moved to apply one of the clutches, the brake is released by the same oil pressure that applies the clutch.

The winches have an intermediate gear assembly that gives a gear reduction and increases the available torque at the winch drum. A sliding sleeve with splines engages the drum pinion gear and the intermediate gear. The operator can disengage the sliding sleeve with a control lever for the **FREESPOOL** operation when there is no load on the cable. When the control lever is in the **FREESPOOL** position, the sliding sleeve disengages the drum pinion gear from the intermediate gear. The gear train is disengaged from the clutch and brake shaft so that the cable can be pulled from the drum by hand. Only

the drum and drum pinion gear rotate when the cable is pulled from the drum during a **FREESPOOL** operation.

A drum gear is connected to the drum and engages the drum pinion gear. When power is applied to the gear train, the drum will rotate in the **LINE IN** or **LINE OUT** direction. One side of the winch case has a bearing support for the tapered roller bearings that hold the drum adaptor. The drum adaptor connects the drum to the drum gear. The other side of the drum runs on roller bearings held by a drum shaft. The drum shaft is connected to the winch case.

Nameplate

The rated capacity for the winch, as it is equipped, must be shown on the nameplate. Each winch is shipped from the factory with a nameplate as shown in FIGURE 2. If the nameplate is missing, or the cable does not match the information on the nameplate, do not operate the winch

until its capacity is known and a new nameplate is installed. Each winch must be operated within its rated capacity as shown on the nameplate.

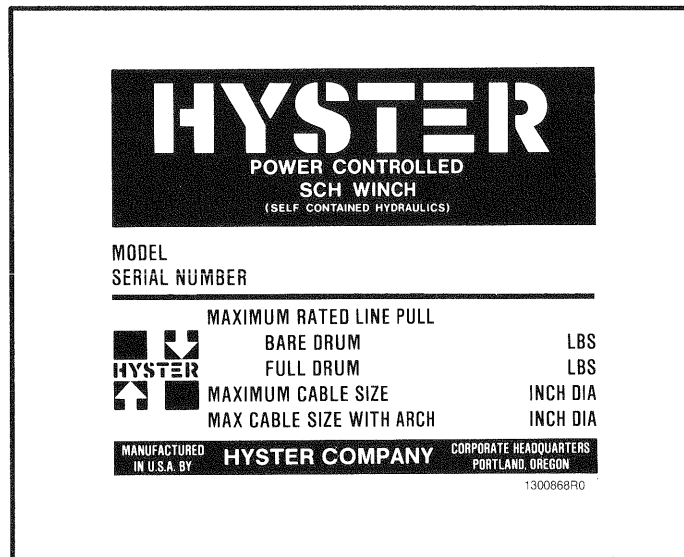

FIGURE 2. NAMEPLATE

Cable Selection

Each model of winch can have a variation of cable (wire rope) sizes installed by the user. The maximum cable size is shown on the nameplate. When a larger diameter cable is used, the less length of cable can be installed on the drum. The winch can create a tension in the cable that is greater than the strength of the cable. The user must be careful to select a cable that has enough strength and length for the job.

WARNING

During operation of the winch, the operator must know or estimate the line pull and make sure that the line pull is within the capacity of the winch and the specifications of the cable installed on the drum. A broken cable under high tension can return suddenly in the direction of the winch and cause injury and damage.

W3A AND W3.5B WINCH

DESCRIPTION

The W3A winch is the first model of the W3 series of winches and was manufactured from 1982 to 1988. The W3.5B winch is a later model of the same design manufactured after August 1988. The operation of both models of winches is the same.

The W3A and W3.5B winches have a power forward (**LINE IN**) function only and is used on skidders and tractors with a constant running PTO. The **BRAKE OFF** and **FREESPOOL** functions permit the cable to be pulled from the drum. The **SCH** (Self Contained Hydraulics) indicates that the hydraulic system for winch operation is inside the winch case. A hydraulic pump is connected by a

gear drive to the constant running pinion. Access covers on both sides of the winch case permit service repairs and adjustments. The design of the winch case permits different arrangements of PTO assemblies to fit the different skidders and tractors that use this winch.

The W3A winch has a maximum line pull capacity of 133 440 N (30 000 lbf) when there is one layer or less of cable on the drum.

The W3.5B winch has a maximum line pull capacity of 155 680 N (35 000 lbf) when there is one layer or less of cable on the drum. When there is more than one layer of cable on the drum, the maximum line pull capacity is reduced to 133 440 N (30 000 lbf).

1. DRUM SHAFT
2. ACCESS COVER, STRAINER
3. ACCESS COVER, HYDRAULIC SYSTEM
4. DRAIN PLUG
5. PLUG, OIL LEVEL CHECK
6. ACCESS COVER, HYDRAULIC VALVE
7. FILL PLUG
8. SUPPORT BRACKET, FREESPOOL SHIFTER FORK
9. ACCESS COVER, DRUM GEAR
10. BEARING RETAINER, INTERMEDIATE SHAFT
11. COVER, OIL BRAKE
12. ACCESS COVER, CLUTCH AND PINION
13. FERRULE POCKET

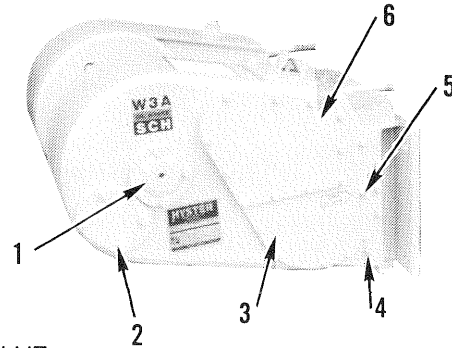

10758

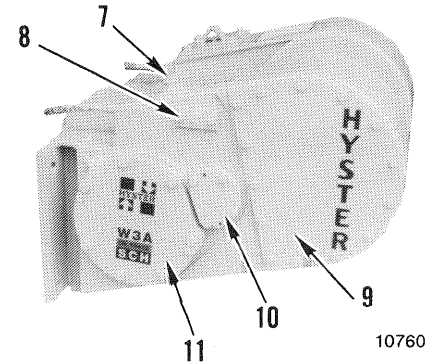

10760

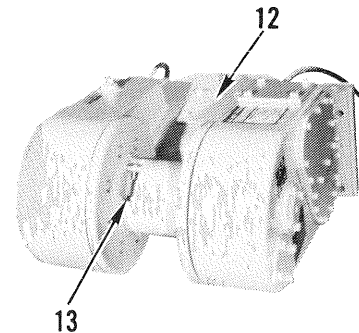

10759

W3A WINCH IS SHOWN.
W3.5B WINCH HAS SIMILAR COMPONENTS

FIGURE 3. W3A TOWING WINCH

Optional Equipment

(All of the optional equipment is not available for each model of tractor or skidder.) The W3.5B winch can have the following optional equipment:

- integral arch
- fairlead assembly
- drawbar
- alternate gear ratio
- alternate drum size

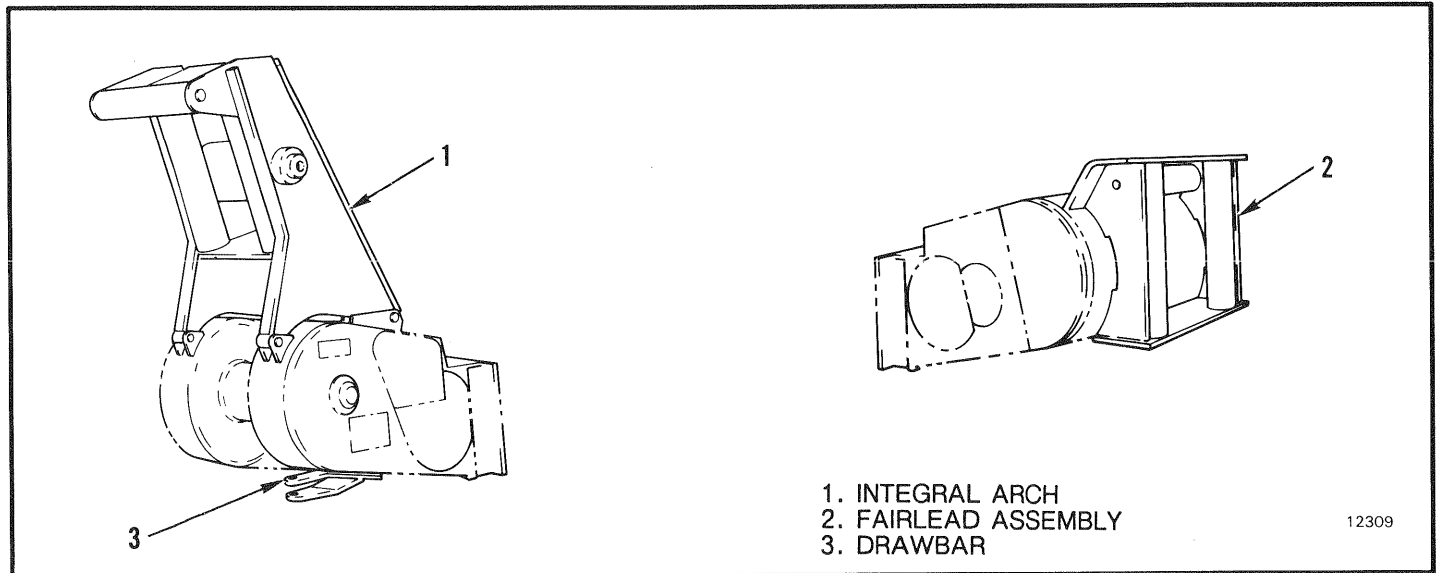

FIGURE 4. W3.5B TOWING WINCH, OPTIONAL EQUIPMENT

W3A AND W3.5B WINCH



SERIAL NUMBER CODES

The nameplate with the serial number code is found below the drum shaft on the right side of the winch case. A serial number indicates the following information:

W3.5B P 3 A 1565 C12
 1 2 3 4 5 6

where:

- 1 = Winch Model
- 2 = Type of winch drive:
(P = Power Controlled Winch)
- 3 = Gear ratio code (see TABLE 1.)
- 4 = A = LINE IN Only with FREESPOOL
- 5 = Sequence number of manufacture
- 6 = Application code for the model of tractor or skidder (see TABLE 1.)

	FIATALLIS	CATERPILLAR	TIMBERJACK	JOHN DEERE	IHC/DRESSER	KOMATSU	CASE	
APPL. CODE	A	C	D	E	H	K	R	GEAR RATIO CODE
11	FD5, FL5 FL5, FL7 *2, #1	D3B *1, #2		450E, 550B 455E, 555B *5, #2	TD7E (Note 3) *1, #2	D31 D37 *2	450B *1, #2	1 = 29.7:1 2 = 49.8:1 3 = 19.8:1
12		518 (Note 1) *3	350/380/450 *4	450G/650G *5, #2	TD8E *1, #2		850B (Note 4) *1, #2	4 = 26.2:1 5 = 39.4:1
13		518 (Note 2) *3	(Note 1) CAT 518 S/N 50S3202 & 55U662 TO 94U1298 & 95U1185 (Note 2) CAT 518 S/N 94U1298 & 95U1185 & UP (Note 3) IHC TD7E beginning with S/N Prefix 4410019 (Note 4) IHC TD8E beginning with S/N Prefix 4420012					
	* Indicates standard gear ratio # Indicates optional gear ratio							

TABLE 1. TRACTOR OR SKIDDER APPLICATION CODES

CABLE DIAMETER	DRUM CAPACITY	
	Drum Diameter = 178 mm (7 in)	Drum Diameter = 216 mm (8.5 in)
16 mm (5/8 in)	65 m (212 ft)	56 m (184 ft)
19 mm (3/4 in)	45 m (147 ft)	39 m (128 ft)

TABLE 2. DRUM LINE CAPACITIES

OPERATING PROCEDURES

Two control levers are used for winch control. See FIGURE 5. The power control lever is used to select one of the following operations:

- LINE IN
- BRAKE ON
- BRAKE OFF (brake release inching)
- BRAKE OFF (DETENT)

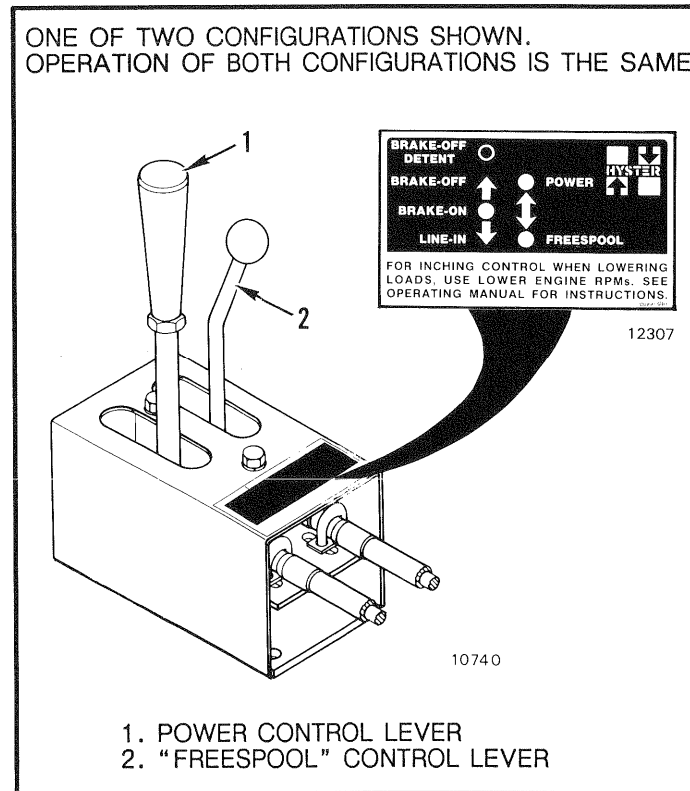

FIGURE 5. OPERATOR CONTROLS

Except for the **BRAKE OFF (DETENT)** position, the power control lever will return to the **BRAKE ON** position when the control lever is released. A spring arrangement on the spool of the control valve returns the spool and control lever to the **BRAKE ON** position. A ball and detent will hold the spool and control lever in the **BRAKE OFF (DETENT)** position. The operator must pull the control lever from the DETENT position.

The **FREESPOOL** control lever has two positions: **POWER** and **FREESPOOL**. The **FREESPOOL** control lever disengages the gear train so that the cable can be pulled from the winch by hand.

POWER OPERATION

The **BRAKE ON** position is a neutral position. The clutch is not applied. The springs in the brake fully apply the brake. The winch drum will not turn.

The **LINE IN** position applies the **LINE IN** clutch and releases the brake. The winch will wind the cable at a speed controlled by the engine rpm or the output of the torque converter of the vehicle.

BRAKE OFF (brake release inching) occurs when the operator moves the control lever towards the **BRAKE OFF** position. The winch must have a load on the cable. This action will slowly release the brake and permit the cable to slowly unwind against the partial brake friction. The brake friction is controlled by the distance that the operator pushes the control lever toward the **BRAKE OFF** position. The engine of the tractor or skidder must be at low idle for best control.

The **BRAKE OFF (DETENT)** position completely releases the brake and does not apply hydraulic pressure to the clutch. The winch must have a load on the cable. This position will permit the cable to unwind from the drum against the friction of the clutch, brake, and gear train. The speed that the cable unwinds is not controlled by the operator, but by the movement of the load or the travel speed of the vehicle.

FREESPOOL OPERATIONS



WARNING

The control lever normally can not be moved to the **FREESPOOL** position if there is a load on the cable. If

enough force were used to disengage the gear train for the FREESPOOL operation, an uncontrolled release of the load will occur. Loss of the load can result in injury and damage.

When the FREESPOOL control lever is moved to the FREESPOOL position, the winch drum is disengaged from the gear train. The FREESPOOL operation permits the cable to be pulled from the winch drum by hand.

FREESPOOL ADJUSTMENT

There are two adjustments for the preload that controls the resistance to rotation of the drum during the FREESPOOL operation. The resistance to rotation (drag) is correct when the drum can be rotated by hand, but will not rotate more than one-half revolution after the hand is removed.

A. Bearing Preload. The addition or removal of shims for the preload on the bearings for the drum adaptor re-

quires the removal of the drum gear and disassembly of the bearing assembly. This adjustment is normally only necessary if the “drag” shoe adjustment is not effective. See the **Service Manual** if this adjustment is required. This adjustment must be done by a trained service person.

NOTE: Early production W3A winches do not have a “drag” shoe adjustment and the bearing preload is the only adjustment available.

B. Drag Shoe Adjustment. See FIGURE 6. Loosen the 3/4 inch lock nut (1) on the setscrew (2). Use a 3/8 inch Allen wrench to turn the setscrew 1/4 turn. Turn the setscrew to the right (clockwise) to increase the “drag” or turn the setscrew 1/4 turn to the left (counterclockwise) to decrease the “drag”. Tighten the lock nut. Test the “drag” on the drum. Make additional adjustments as necessary.

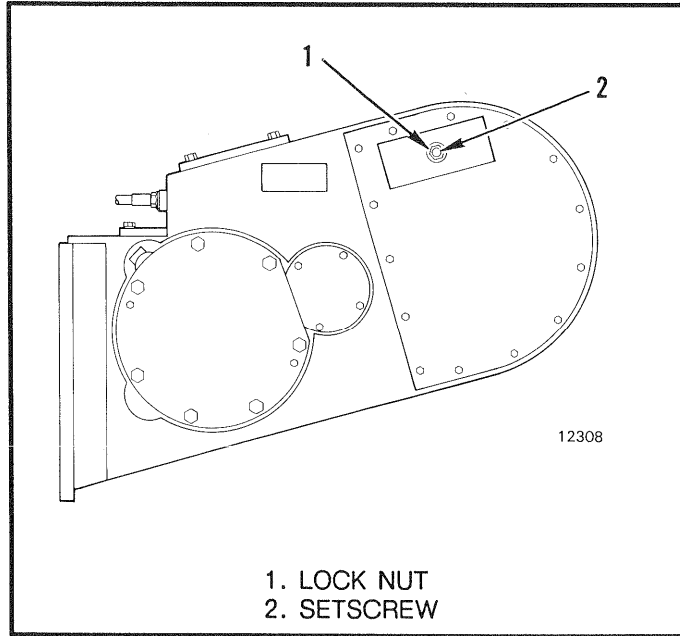

FIGURE 6. "DRAG" SHOE ADJUSTMENT

CHECKS BEFORE OPERATION

Check that the cable and hook are not worn or damaged. Check that the periodic inspection and maintenance has been done at the recommended operating hours. See The **Maintenance Schedule** for the W3A or W3.5B winch.

CHECKS DURING OPERATION

The following Troubleshooting Chart can be used by the operator to identify a problem with the winch operation. A trained service person is needed for additional troubleshooting and repair that requires disassembly of parts of the winch.

W3A/W3.5B TROUBLESHOOTING CHART

PROBLEM	POSSIBLE CAUSE	CORRECTION
Operation is rough or not regular	Hydraulic oil is too cold	Put the control lever in the BRAKE OFF position. Run the engine at 1000 rpm to warm the oil before operating the winch.
	Low oil level	Add hydraulic oil to the correct level.
	Control cables need adjustment	Check for correct adjustment. Make sure the ends of the cables are fastened correctly.
	Low oil pressure	See the SERVICE MANUAL for additional Troubleshooting.
Hydraulic oil becomes too hot	Winch is operated in the BRAKE OFF position for long periods	Use the BRAKE OFF position less. When the BRAKE OFF position is used, the hydraulic oil flows continuously through the relief valve. See the SERVICE MANUAL for additional Troubleshooting.
Winch brake does not apply or release correctly		See the SERVICE MANUAL for Troubleshooting.
LINE IN clutch does not apply correctly		See the SERVICE MANUAL for Troubleshooting.
FREESPOOL does not operate correctly		See the SERVICE MANUAL for Troubleshooting, checks and adjustments.

W3A AND W3.5B WINCH

OPERATING TECHNIQUES

Skidder Or Tractor Operation

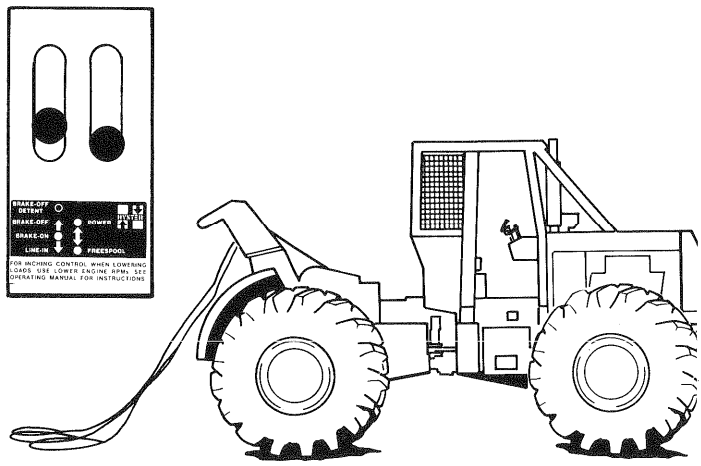

12306

STEP 1. The skidder or tractor is moved to an area where a load will be connected. The operator moves the control lever to the **FREESPOOL** position so that the cable can be pulled from the winch drum.

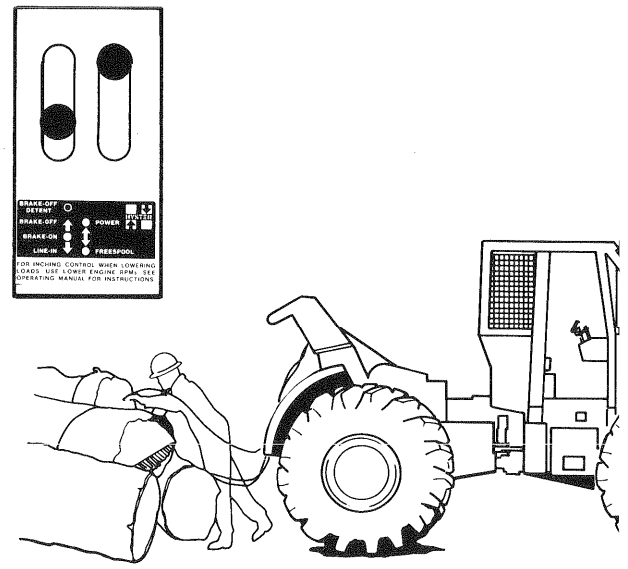

12306

STEP 2. A load (logs) is connected to the cable. The operator moves the **FREESPOOL** control lever to the **POWER** position.

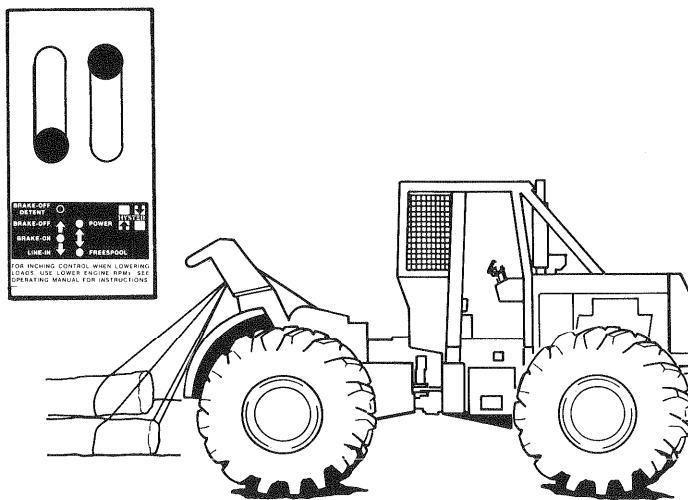

12306

STEP 3. The operator can move the control lever to the **LINE IN** position. If the load is less than approximately 75% of the maximum line pull, the operator can begin traveling with the vehicle at the same time. The winch will wind the load toward the vehicle as it travels. If the load is nearly the capacity of the line pull, the operator must move the load close to the vehicle before beginning to travel.

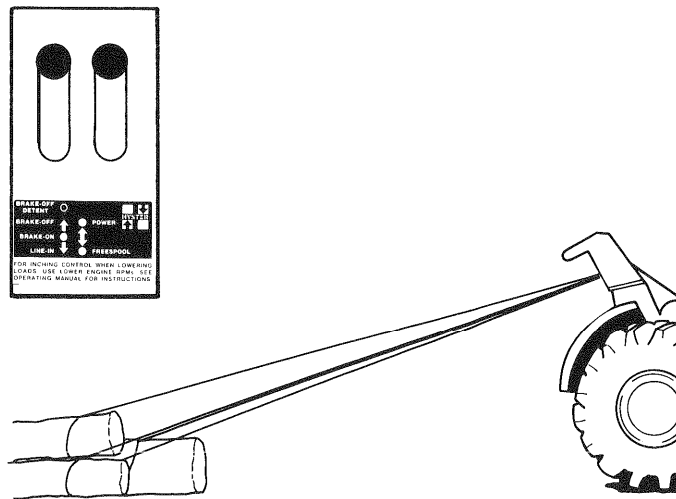

12306

STEP 4. If the vehicle must travel through an area with bad traction conditions, the operator can move the control lever to the **BRAKE OFF (DETENT)** position. This procedure will permit the vehicle to move through the bad traction area without pulling the load at the same time.

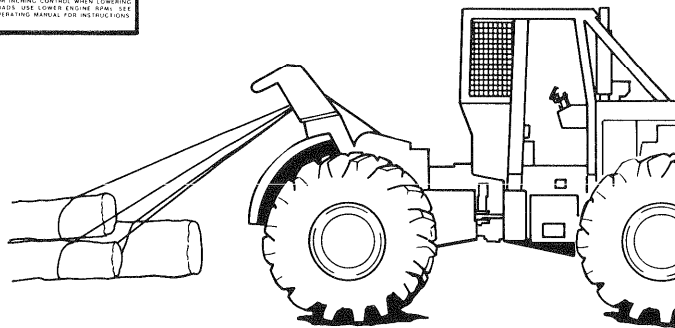
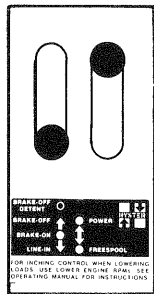

12306

STEP 5. When the vehicle is on firm ground, the operator can move the control lever to **LINE IN** to pull the load toward the vehicle.

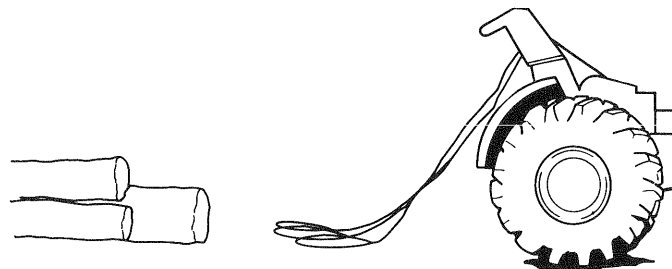
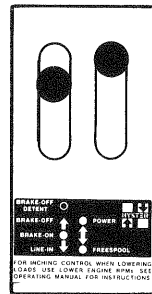

12306

STEP 6. When the operator wants to disconnect from the load, the vehicle is stopped and the control lever is moved to the **BRAKE OFF** position to lower the load. Move the vehicle in reverse as necessary to loosen the cable. The cable is then disconnected from the load.

HOW TO MOVE A DISABLED VEHICLE

A. A skidder or tractor often travels in areas where traction conditions are bad. A skidder or tractor equipped with a winch can be used to remove itself from mud or other area where it can not move using only the drive wheels or tracks. See FIGURE 7. Use the following procedure:

1. Fasten the winch cable to a structure, tow bar of another vehicle, or a tree that has enough strength for the line pull. The cable must be in a direction that is approximately parallel to the direction of travel of the vehicle.
2. Use the throttle to set the engine speed at a power level to operate both the winch and the tracks or drive wheels. (Operator experience is required, because the winch can use most of the engine power in some vehicles.)
3. Use the **LINE IN** control lever to tighten the winch cable. When the winch cable is tight, put the vehicle transmission in **REVERSE** and engage the tracks or drive wheels. Use the power from the engine to the

winch and tracks together to remove the vehicle from the bad area.

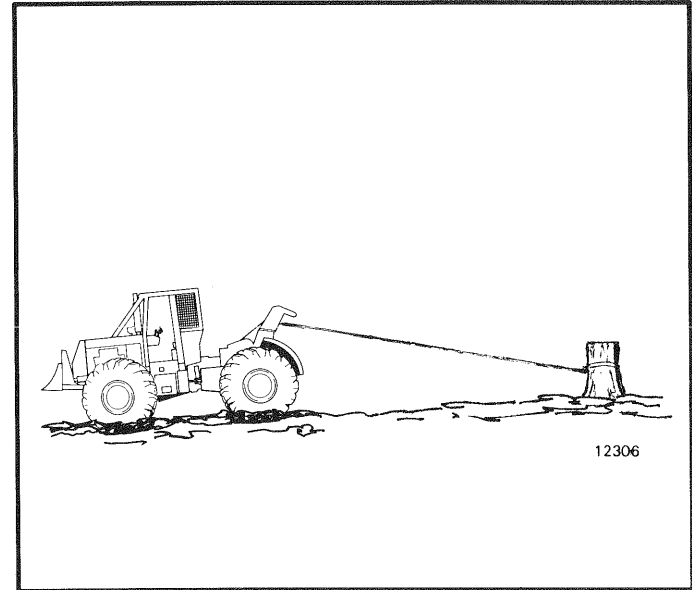

FIGURE 7. MOVE A DISABLED VEHICLE (STEP A)

4. If the tractor travels faster than the winch winds the cable, disengage the transmission until the winch cable is tightened again.

NOTE: If the tracks or drive wheels on the vehicle stop turning, the torque converter in the transmission has stalled and the winch will stop also.

B. A skidder or tractor equipped with a winch can be used to pull another vehicle from mud or other area where it can not move using only the drive wheels or tracks. See FIGURE 8. Use the following procedure:

1. Fasten the winch cable to the tow bar of the other vehicle. The cable must be in a direction that is approximately parallel to the direction of travel of the vehicle. Apply the brakes on the towing vehicle. Use the throttle to set the engine speed at a power level to operate the winch. (Operator experience is required, because the winch can use most of the engine power in some vehicles.)



WARNING

Use extra care if the traction conditions are bad or if the vehicles are on a slope. Bad traction conditions can cause the disabled vehicle or the towing vehicle to slide. A slope can require additional distance to stop the vehicles.

Make sure the cable and tow chain has the capacity to do the job. If the disabled vehicle does not have a tow pin or other equipment for towing, carefully fasten the tow chain around the axle of the disabled vehicle. Make sure the tow chain is fastened so that the chain will not cause injury to people or damage to the vehicle.

An operator must be on the disabled vehicle to operate the steering and brakes when it is towed.

2. Use the **LINE IN** control lever to tighten the winch cable. When the winch cable is tight, use the power from the engine to the winch to pull the vehicle from the bad area. If the disabled vehicle moves under its own power, keep the towing cable tight so that the cable does not pass under the drive wheels or tracks of the vehicle being towed.

MAINTENANCE

The Maintenance Schedule is a program that includes periodic inspection and lubrication. Use the operating time on the hour meter of the tractor to find the maintenance time for the winch.

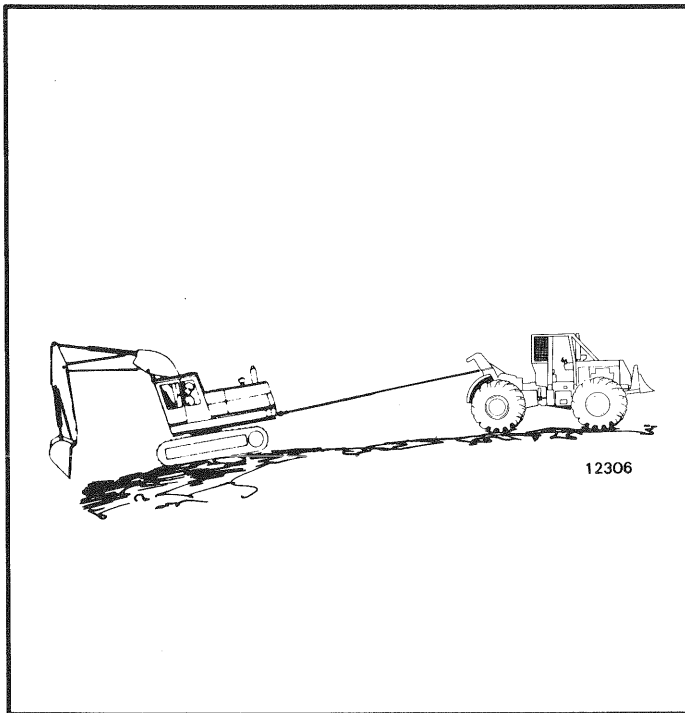

FIGURE 8. MOVE A DISABLED VEHICLE (STEP B)

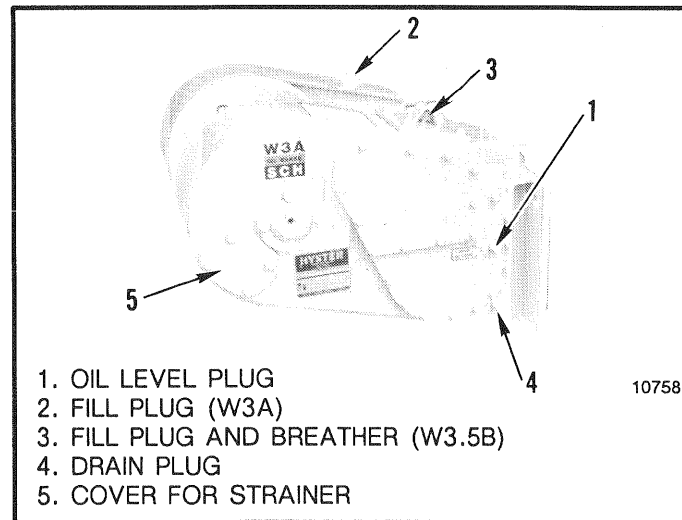

FIGURE 9. MAINTENANCE POINTS (W3A SHOWN)



MAINTENANCE SCHEDULE

INTERVAL	PROCEDURE OR QUANTITY	SPECIFICATION
50 hours or weekly	<p>Check oil level at plug 1. Add oil as necessary at fill plug. (Do not operate the tractor when checking the oil level.)</p> <p>Lubricate the winch control lever and the FREESPOOL control lever.</p> <p>Clean the breather in the fill plug.</p> <p>Lubricate the rollers on the integral arch or the fairlead assembly if the winch is equipped with this optional equipment.</p>	<p>See TABLE 1.</p> <p>Use SAE 30 oil on the linkage as needed. Check that the control cable and control housing are fastened correctly. Tighten the U-bolts as necessary.</p> <p>Clean the breather with solvent.</p> <p>Use multi-purpose grease with 2-4% molybdenum disulphide.</p>
500 hours or 3 months	Clean the oil strainer.* Use a new gasket between the cover and suction tube.	See parts manual for strainer element.
2000 hours or 12 months	Change the hydraulic oil. Drain oil from plug C. Clean the strainer. Add 24 litres (25 qt) through fill plug. Check the oil level at plug 1.	See TABLE 1.

*NOTE: Clean the oil strainer after the first 50 hours on new and rebuilt winches.

Control Cable Adjustments

There are two configurations of operator controls normally used with the W3A/W3.5B winches. Check the operation of the power control lever to make sure it moves smoothly and will return to the **BRAKE ON** position. The power control lever will stay in **BRAKE OFF** when pushed into the **DETENT** position. **Make sure the control lever does not hit the housing at the end of its travel.** Adjustments for both configurations are described in the following paragraphs.

A. See FIGURE 10. Check that the positions of the power control lever are the same as the position indicators on the control housing. Remove the two capscrews and raise the cover. Loosen the U-bolt that holds the control cable in the housing to adjust the hand lever. Install the cover when the adjustments are complete.

Check that the positions of the **FREESPOOL** lever are the same as the position indicators on the control housing. See FIGURE 10. Loosen the U-bolt that holds the control cable in the housing to adjust the control lever. The linkage and cable must be adjusted so that the **FREESPOOL** shifter mechanism will slide the drum pinion gear to both positions. Both positions have a detent.

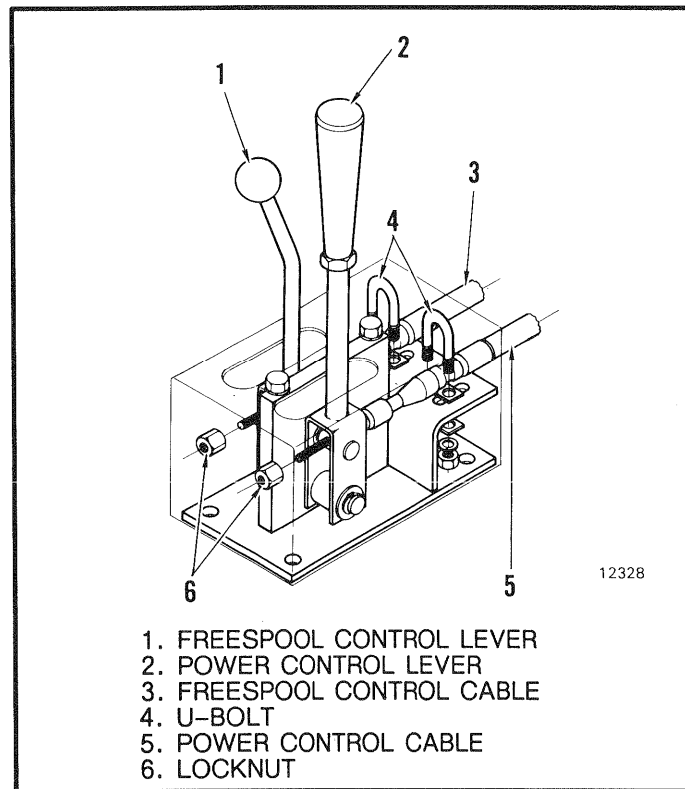
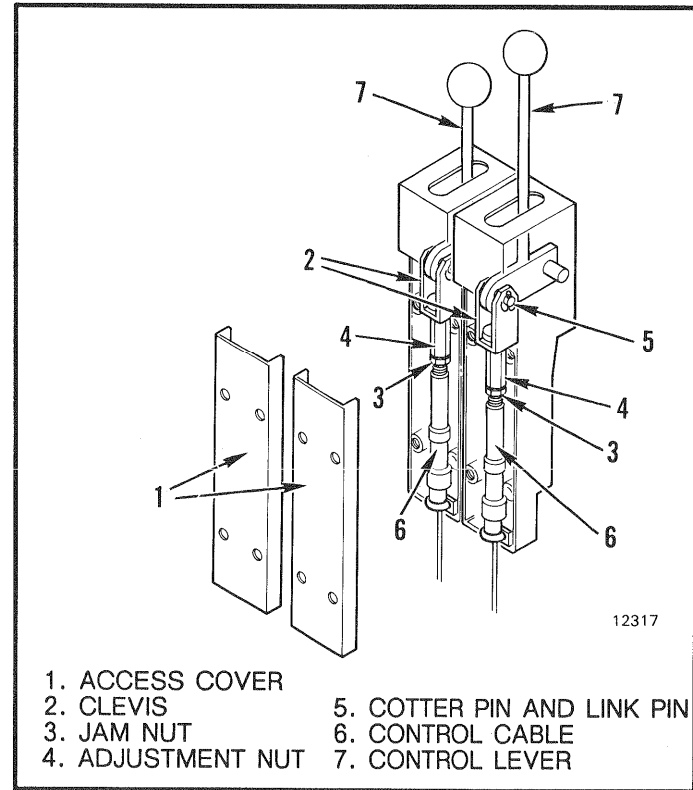

FIGURE 10. CONTROL CABLE ADJUSTMENTS

B. See FIGURE 11. Check that the positions of the power control lever are the same as the position indicators on the control housing. Remove the access cover on the housing to make adjustments. Loosen the jam nut that keeps the adjustment nut and clevis from turning. Remove the cotter pin and link pin from the clevis. Turn the adjustment nut and clevis to adjust the length of the the control cable. Use the link pin and cotter pin to connect the clevis to the control handle again and check the operation. When the adjustment is complete, install the access cover.

Check that the positions of the **FREESPOOL** lever are the same as the position indicators on the control housing. See FIGURE 11. Remove the access cover on the housing. Loosen the jam nut that keeps the adjustment nut and clevis from turning. Remove the cotter pin and link pin from the clevis. Turn the adjustment nut and clevis to adjust the length of the the control cable. Use the link pin and cotter pin to connect the clevis to the control handle again and check the operation. When the adjustment is complete, install the cover. The linkage and cable must be adjusted so that the **FREESPOOL** shifter mechanism will slide the drum pinion gear to both positions. Both positions have a detent.



- | | |
|-------------------|----------------------------|
| 1. ACCESS COVER | 5. COTTER PIN AND LINK PIN |
| 2. CLEVIS | 6. CONTROL CABLE |
| 3. JAM NUT | 7. CONTROL LEVER |
| 4. ADJUSTMENT NUT | |

FIGURE 11. CONTROL CABLE ADJUSTMENTS

The type of oil used in current Hyster winches affects the line control. Use ONLY the following oils in the W3A and W3.5B winches:

COMPANY	BRAND NAME
Amoco Oil Company	Amoco 1000 Fluid
Exxon Company	Torque Fluid 56
John Deere	Hy-Gard Transmission & Hydraulic Oil
Sun Oil Company	Sunfleet TH Universal Tractor Fluid

TABLE 1. APPROVED OIL LIST

NOTES

NO MATTER HOW YOU SAY IT . . .

La Prudence Paye
La Seguridad Paga
Betriebsicherheit Macht Sich Bezahlt
Passaa Olla Huolellinen
Veiligheid Voor Alles
Säkerhet Först
Essere Sicuro Paga
Segurança Paga
Sikkerhet Først
Pinter Be Awas

सावधान और बिन्दा रहौ ।

في التاني السلامة

安全
第一

**SAFETY
PAYS!**

OPERATING MANUAL

**POWER CONTROLLED
WINCHES
W3A and W3.5B**

**THIS MANUAL MUST BE WITH THE VEHICLE
ON WHICH THIS WINCH IS INSTALLED**



Trademark under license from Hyundai Company

P/N 599001W