

Operating Manual

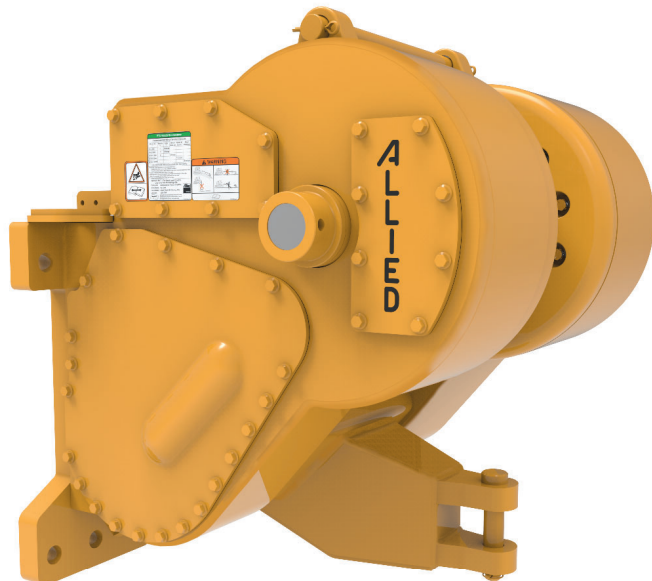

W12E

Towing Winch

for Caterpillar Dozers

This manual must be with the vehicle on which this winch is installed.

Please check the Allied Systems website regularly for updates to this manual.
www.alliedsystems.com

Applicable to winches with serial number AW12E**1749**** and later.

A Product of
Allied Systems
COMPANY
Sherwood, OR USA

P/N 599012W-CAT

Printed in U.S.A.

01/29/2024

Winch Model W12E

Serial Number _____

Date Delivered _____

Date Installed _____

Special Equipment or Attachments



A Product of Allied Systems Company
Sherwood, Oregon
U.S.A.



01/29/2024
Printed in U.S.A.

Foreword

The safe and efficient operation of a winch requires skill and alertness on the part of the operator. To develop the skills required, the operator must:

- Receive training in the proper operation of the winch and the machine on which it is mounted.
- Understand the capabilities and limitations of the winch and the machine on which it is mounted.
- Become familiar with the winch and the machine on which it is mounted and see that they are maintained in good condition.
- Read and understand the SAFETY SUMMARY and OPERATING PROCEDURES contained in this Operating Manual.

In addition, a qualified person experienced in the operation of the winch must guide a new operator through several load handling applications before the new operator attempts to operate the equipment alone. It is the employer's responsibility to make sure that the operator can see, hear, and has the physical and mental ability to operate the equipment safely.

This Operating Manual contains basic information necessary for the operation and maintenance of a winch. Optional equipment is sometimes installed that can change the characteristics described in this manual. Make sure the necessary instructions are available and understood before operating the winch.

Some of the components described in this Operating Manual will NOT be installed on your winch. If you have questions about any item on your winch or described in this Operating Manual, contact your local winch dealer, or contact Allied Systems Company:

Allied Systems Company
21433 SW Oregon Street
Sherwood, OR 97140
U.S.A.

Phone: 503-625-2560

Fax: 503-625-7269

E-Mail: marketing@alliedsystems.com

Also visit our website, www.alliedsystems.com, where the most current copy of this manual is always available.

Note: For repairs and overhaul, contact your Allied winch dealer. If you maintain your own equipment, a service manual is available for your specific winch.

Note: This publication may be translated to different languages for sole purpose of easy reference in non-English speaking locations. Should there be differences in interpretations to the text, please refer to the English language edition published by Allied Systems Company as the controlling document.

Contents

Foreword	i
Contents	iii
Safety Summary	iv

General

Introduction	1
How The Winch Operates	1
Nameplate	2
Wire Rope Selection	3
Recommended Oil List & Oil Capacity	4
W12E Winch Description	5
Optional Equipment	6
Serial Number Codes	7
Caterpillar Vehicle Codes	8

Operation

Checks Before Operation	9
Checks During Operation	9
Operating Procedures	10
Operation	13
Inching	14
Troubleshooting Chart	15

Maintenance

Maintenance	19
Maintenance Points	20
Maintenance Schedule	21

Operating Techniques

Dozer or Skidder Operation	23
How To Move A Disabled Vehicle	25
Working on A Steep Slope	27
Tractor Is Down The Slope	27
Other Equipment Is Down The Slope	28

Operational Differences, Optional Equipment

Fairlead	30
Drawbar	30
Optional Gear Ratios	30

Safety Summary

General Safety Notices

The following pages contain general safety warnings which supplement specific warnings and cautions appearing elsewhere in this manual. All electrical and hydraulic equipment is dangerous. You must thoroughly review and understand the Safety Summary before attempting to operate, troubleshoot or service this winch.

The following symbols/terms are used to emphasize safety precautions and notices in this manual:



DANGER

The “**DANGER**” symbol indicates a hazardous situation which, if not avoided, will result in death or serious injury. Carefully read the message that follows to prevent serious injury or death.



WARNING

The “**WARNING**” symbol appears wherever incorrect operating procedures or practices could cause serious injury or death. Carefully read the message that follows to prevent serious injury or death.



CAUTION

The “**CAUTION**” symbol appears where a hazardous situation which, if not avoided, could result in minor to moderate injury and equipment damage.

NOTICE

This signal word alerts to a situation that is not related to personal injury but may cause equipment damage.

NOTE: ...

The term “NOTE” highlights operating procedures or practices that may improve equipment reliability and/or personnel performance.

Safety Regulations

Each country has its own safety legislation. It is in the operator’s own interest to be conversant with these regulations and to comply with them in full. This also applies to local bylaws and regulations in force on a particular worksite.

Should the recommendations in this manual deviate from those in the user’s country, the national regulations should be followed.

NOTE: All possible safety hazards cannot be foreseen so as to be included in this manual. Therefore, you must always be alert to potential hazards that could endanger personnel and/or damage the equipment.

Operation, Inspection, and Maintenance Warnings

WARNING

The winch shall not be used for hoisting.

WARNING

Use hearing protection when operating winches.



Obey the following cautions and warnings before using your winch to avoid equipment damage, personal injury or death.

- Do not operate the winch unless you are authorized and trained to do so.
- Do not operate the winch unless the vehicle is equipped with a screen to protect the operator if the wire rope breaks.
- Read, understand, and follow the operating, inspection, and maintenance instructions in this Operating Manual.
- Do not use the control levers for hand holds when entering or leaving the vehicle.
- Do not permit other people near the control area when you inspect or repair a machine.
- Never inspect, repair, or perform maintenance on a machine that is in motion.
- Inspect the winch before each use:
 - » Make sure that the controls and instruments operate correctly.
 - » Report the need for repairs immediately.
- » Do not work with a damaged or worn wire rope.
- » Do not use a winch that needs repairs.
- » If the wire rope and ferrule must be removed from the drum, make sure the end of the wire rope and ferrule are controlled when the ferrule is released. The end of the wire rope can suddenly move from the drum like a compressed spring when the ferrule is released and cause an injury.

- Stay in the operator's seat when operating the winch.
- Do not stand on the vehicle when operating the winch.
- Avoid winch operation near people or other machines.
- Never stand nor permit others to stand in the bight (loop) of a wire rope.
- Do not stand nor permit others to be near the winch or wire rope when there is tension on the wire rope.
- Observe jobsite rules.
- Be in complete control at all times.
- Do not use the control levers as hangers for clothes, water bags, grease guns, lunch pails, etc.

Safety Summary

- Do not leave the vehicle when the winch wire rope is under tension.
- Do not permit riders on the vehicle or load.
- Do not use the winch as an anchor for a double or two-part line.
- Do not pull the hook through the throat or over the drum, which will cause damage.
- When the winch is not in use, make sure the control lever is in **BRAKE-ON** position and the winch brake is applied.
- Do not use winch as a hoist. Tractor and skidder mounted winches are designed for towing.

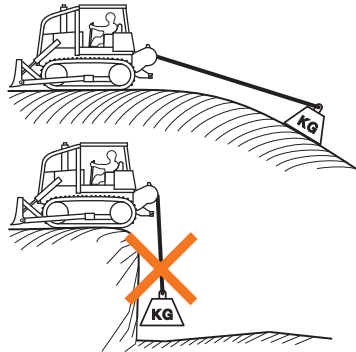

- Always inspect wire rope, tail chain and other rigging components for wear, damage, broken strands or abuse before use.
- Never use wire rope, tail chain or other rigging that is worn-out, damaged or abused.
- Never overload wire rope, tail chain or rigging.
- Wire rope and tail chain will fail if worn-out, overloaded, misused, damaged, improperly maintained or abused. Wire rope or tail chain failure may cause serious injury or death!



- Do not terminate wire rope to tail chain by the use of a knot.



- Do not handle wire rope if the hook end is not free. A load could break away, suddenly tensioning the wire rope, resulting in serious injury or death.
- Stay clear of wire rope entry areas (fairlead or arch rollers, winch drum etc).
- Make sure ground personnel are in plain view of the operator, and at a distance of at least 1½ times the working length of the wire rope.
- Make sure that any hand signals used by ground personnel are clearly defined and understood by everyone involved.
- Do not attempt to “jerk” or “shock” a load free. Doing so can cause loads in excess of the rated capacity of the wire rope, winch, or mounting hardware.
- Replace any parts only with genuine Allied Winch parts. Refer to W8L Parts Manual (P/N 599781W).
- Maintain **a minimum of three (3) complete wraps of wire rope** on the drum for normal operation. It may help to paint the last five wraps of wire rope a contrasting color, to serve as a visual indicator.
- Do not handle wire rope with bare hands. Wear leather gloves at all times.
- Align the tractor with the load to prevent side loading the winch, and to maintain even spooling of the wire rope.
- If applying tension to the wire rope manually during spooling:
 - » ensure that the operator is winching in slowly,
 - » keep your hands and clothing well clear of any rollers or the winch drum,
 - » do not maintain tension by letting the wire rope to slip through your hands,
 - » use a hand-over-hand technique to maintain tension.
- Be aware of the ground conditions, and make sure the ground and tractor are stable enough to pull the intended load.
- Do not attempt to pull loads in excess of the rated capacity of the winch.
- Keep yourself informed of any applicable codes, regulations and standards for the job.
- Your winch may have temperature shut-off system for protection of tractor and winch. Manual override of high temperature shut-off will cause damage to tractor and winch.

Safety Summary

- This winch is neither intended, designed, nor rated for any application involved in the lifting or moving of personnel.
- Use only the lubricants listed in the Recommended Oil List. See Page 5.
- Do not weld on any part of the winch. Contact Allied Systems if weld repairs are needed.
- The hydraulic system must be kept clean and free of contamination at all times.
- Be aware of the hazards of pressurized hydraulics:
 - » Wear personal protective equipment, such as gloves and safety glasses, whenever servicing or checking a hydraulic system.
 - » Assume that all hydraulic hoses and components are pressurized. Relieve all hydraulic pressure before disconnecting any hydraulic line.
 - » Never try to stop or check for a hydraulic leak with any part of your body; use a piece of cardboard to check for hydraulic leaks.
 - » Small hydraulic hose leaks are extremely dangerous, and can inject hydraulic oil under the skin, even through gloves.

- » Infection and gangrene are possible when hydraulic oil penetrates the skin. See a doctor immediately to prevent loss of limb or death.



Product Modifications

- Any alterations to the winch that have not been approved by Allied Systems Company, or use of any non-OEM replacement parts, will void the warranty, and may introduce serious safety hazards.
- Any non-OEM parts used, or any alterations made are done so at your own risk to personnel safety. This includes the addition of accessories and attachments not manufactured or approved by Allied Systems Company.



Intentionally Blank

General

Introduction

This Operating Manual contains basic information necessary for the operation and maintenance of the W12E winch.

How the Winch Operates

A winch is normally installed on a skidder or dozer:

- to increase the pulling power of the skidder or dozer.
- to reach into an area where a skidder or dozer cannot go.
- to make lift functions available when special attachments are installed.

The winch has hydraulic clutches that are similar to a hydraulic (powershift) transmission. The dozer or skidder has a power take-off (PTO) that is used to connect the power from the engine to the winch. The **SCH** (Self Contained Hydraulics) on the winch label indicates that the hydraulic system for control of the winch is inside of the winch case. When the PTO is operating, a hydraulic pump in the winch case takes hydraulic oil from the winch sump and sends it to the hydraulic control valve. The hydraulic valve controls the operation of the winch.

Removable covers on the winch case allow access for repairs and adjustments.

When PTO is rotating, the hydraulic pump shaft is also rotating. Oil from the hydraulic pump is used to cool and lubricate the winch components. The pressure is connected via gears to an oil clutch for the **LINE-IN** (power forward) operation and another oil clutch for the **LINE-OUT** (power reverse) direction.

The power through the winch to the drum for the wire rope is controlled by a **LINE-IN** and a **LINE-OUT** clutch. When the **LINE-IN** clutch is applied, the drum rotates to pull the wire rope into the winch. When the **LINE-OUT** clutch is applied, the drum rotates to reel the wire rope from the winch at the speed controlled by the engine rpm.

When the control lever is in the **BRAKE-ON** position, the oil brake is automatically applied by a spring to hold the drum in its position. If the control lever is moved to apply one of the clutches, the brake is released by the same oil pressure that applies the clutch. In the event that hydraulic power is lost, the brake remains applied and the winch will not turn.



Nameplate

Each winch is shipped from the factory with a nameplate as shown in Figure 1. The nameplate is stamped with:

- winch model
- winch serial number
- maximum rated bare drum line pull
- maximum wire rope diameter

DO NOT operate the winch with larger diameter wire rope. If the nameplate is missing, DO NOT operate the winch until its capacity is known.

The serial number for the winch is also stamped into the frame next to the nameplate.

Wire Rope Selection

Each winch model can have a variety of wire rope sizes, lengths, or grades installed by the user. The maximum wire rope size is shown on the nameplate. The maximum rated line pull stamped into the nameplate is based on the maximum wire rope size, EEIPS grade. When a smaller diameter wire rope, or a different grade is installed, the line pull is limited by the capacity of the wire rope.

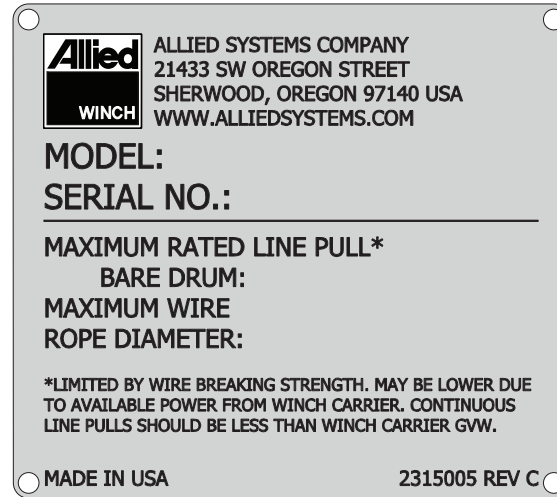

Figure 1 Nameplate

See Figure 2 for approved wire rope sizes, drum capacities and maximum rated line pulls. When a larger diameter wire rope is used, the length of wire rope installed on the drum will be shorter. Be aware that the winch can create a tension in the wire rope that is greater than the strength of the wire rope. The user must be careful to select a wire rope that has enough strength and length for the job.

WARNING

Load loss hazard.

A wire rope that breaks under high tension can suddenly whip back towards the winch, causing injury or product damage.

Be sure the operator knows the capacity of the wire rope and the winch.

WARNING

Load loss hazard.

A loaded wire rope with fewer than three complete wraps on the drum could disengage from the ferrule pocket, causing load loss and possible injury. Paint the last five wraps of wire rope a contrasting color to alert the operator that end of the wire rope has been reached.

Wire Rope Diameter in (mm)	Capacity for Full Drum Fill ft (m)	Capacity for 2/3 Drum Fill ft (m)	EIPS Maximum Rated Line Pull Lbs (N)	EEIPS Maximum Rated Line Pull Lbs (N)
1 (25)	286 (87)	188 (57)	73,800 (328,200)	81,200 (361,100)
1 1/8 (28)	229 (70)	150 (46)	92,800 (412,700)	102,100 (454,100)
1 1/4 (32)	182 (55)	119 (36)	114,100 (507,500)	125,500 (558,200)
NOTE:				
1. Loosely or unevenly spooled line will reduce capacities.				
2. Use flexible wire rope with independent wire rope center.				
3. Ferrule size: 2 1/4 inches diameter, 2 3/8 inches long.				

Figure 2 Wire Rope Sizes and Capacities

Wire Rope Reel

When the wire rope is transferred from a reel to the drum, or from the drum back onto a reel, it must go from “top to top” for overwind winches, or “bottom to bottom” for underwind winches, as shown in Figure 3, to avoid putting a reverse bend into the wire rope.

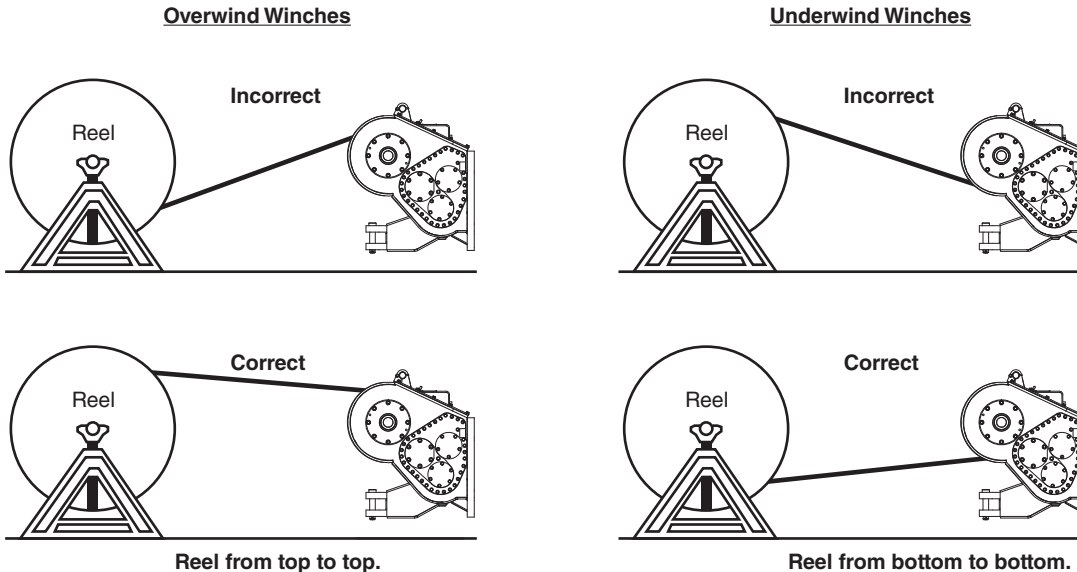

Figure 3 Transferring Wire Rope from or to Reel

Wire Rope Installation



WARNING

Gloves should be worn when working with or near wire rope to prevent cuts and abrasions.

NOTE: The illustrations in this section show a winch with an “overwind” configuration, which is standard. Some winches are configured for “underwind”, with the wire rope spooling onto the bottom of the drum instead of the top. The procedures for installation are the same.

Seat the ferrule on the drum end of the wire rope in the ferrule pocket in the drum. See Figure 4. Use the keeper and related hardware to secure the ferrule. Torque the capscrew to 115 ft-lbs.

Once the ferrule is properly secured in the pocket, the wire rope may be spooled slowly onto the drum. Apply enough tension to the wire rope as it is being spooled to ensure that it spools neatly and tightly on the drum.

Tension may be created by a variety of methods. The methods described here are not exclusive.

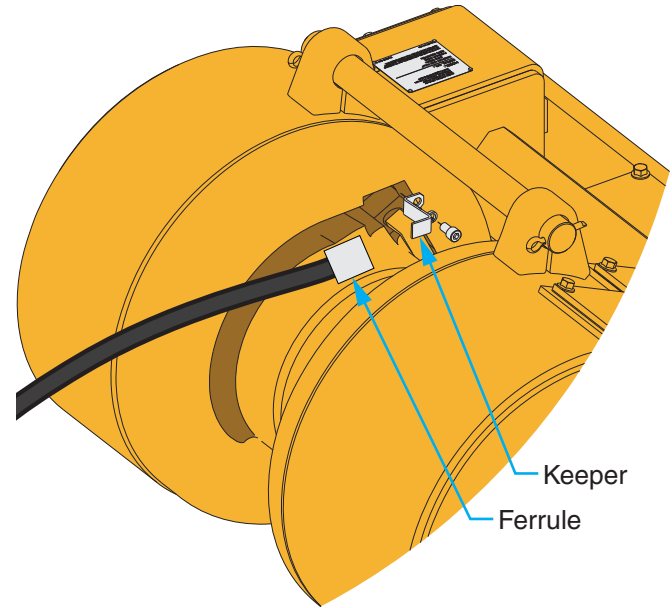

Figure 4 Secure Ferrule in Pocket with Keeper

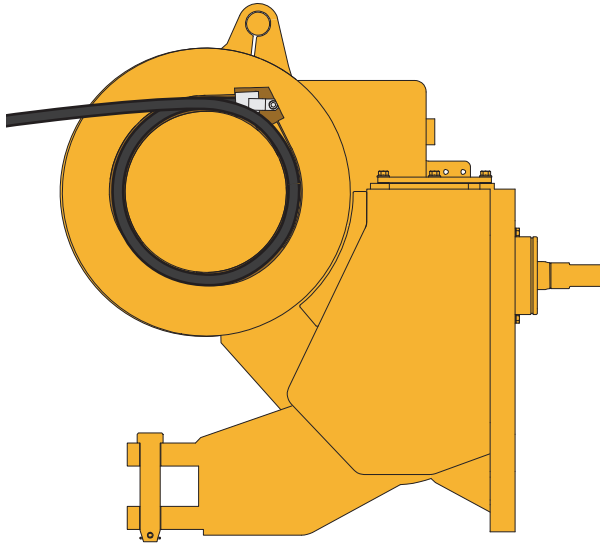

Figure 5 First Layer, Overwind Configuration

One method is to create a wooden plank lever, as shown in Figure 6 to apply pressure to the reel flange(s). The friction between the wooden plank and the reel flange(s) will create resistance to rotation of the reel, which will create tension in the wire rope as it is slowly spooled onto the winch drum.

Another method is to use the tines of a forklift to bear against the reel flange(s). Again, the friction generated between the tines and the flange(s) will create tension in the wire rope.

Finally, the end of the wire rope may be fastened to a forklift. The forklift may be driven away from the winch drum as the wire rope is paid out, and the forklift operator may use the brake on the forklift to provide tension on wire rope as the wire rope is spooled back onto the winch drum. The movement of the forklift and the paying out or spooling back onto the winch drum shall be coordinated to prevent the wire rope from contacting the ground.

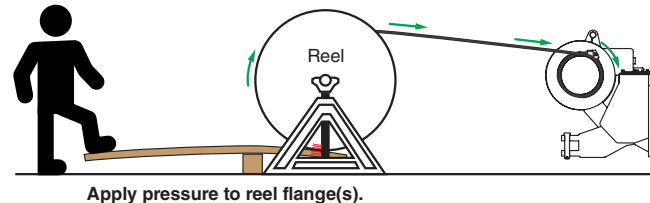

Figure 6 Create Tension

Recommended Oil List and Oil Capacity

The type of oil used in Allied winches affects the line control. Use the following oils in the W12E winch:

Recommended Oils* - General Conditions			
Manufacturer	Oil Type	Ambient Temperature Range	
		°F	°C
ExxonMobil	Mobil Fluid 424 (Factory fill)	-13 to 104	-25 to 40
John Deere	Hy-Gard™	-13 to 122	-25 to 50
Chevron	1000 THF	-13 to 104	-25 to 40
Caterpillar	Multipurpose Tractor Oil (MTO)	-13 to 104	-25 to 40
Case	Hy-Tran Ultra	-20 to 122	-29 to 50
Recommended Oils* - Low Temperature Conditions			
Manufacturer	Oil Type	Ambient Temperature Range	
		°F	°C
ExxonMobil	Mobil Fluid LT	-40 to 86	-40 to 30
John Deere	Low Viscosity Hy-Gard	-40 to 86	-40 to 30
Chevron	THF W	-40 to 86	-40 to 30

* Note: Use of non-recommended oils may void warranty.

Figure 7 Recommended Oil List

Oil Capacity	
W12E Winch Frame	29 Gallons (110 L)
Gear Box	1 Gallon (3.8 L)

Figure 8 Oil Capacity

W12E Winch Description

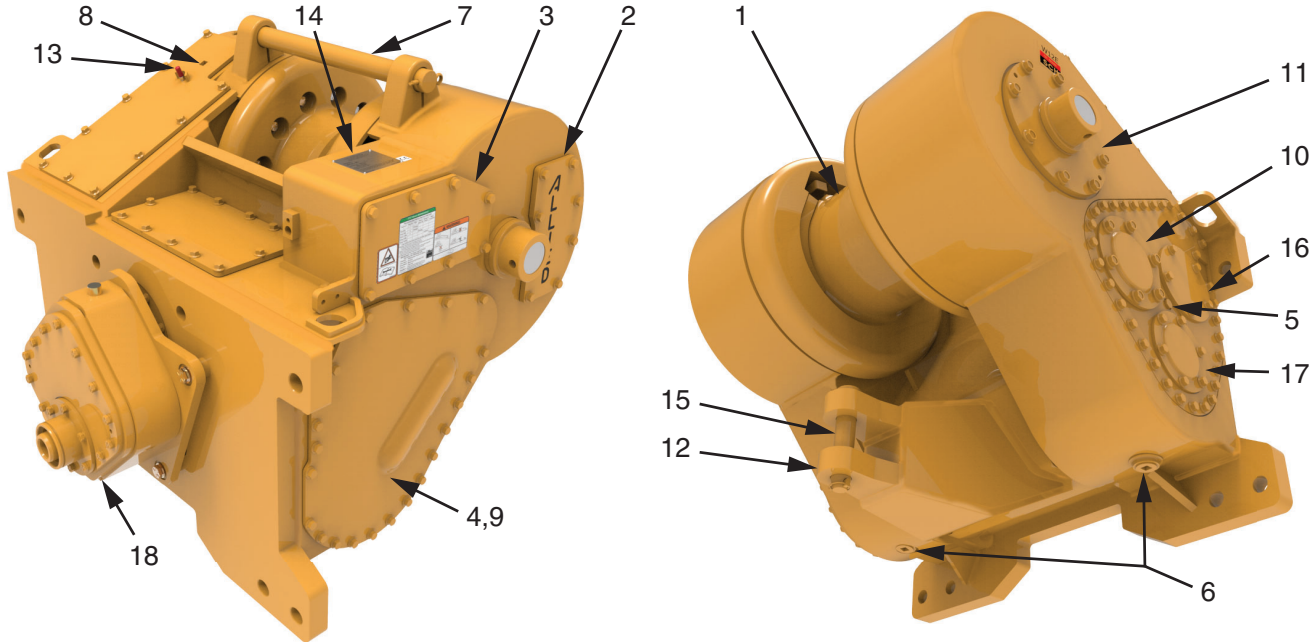

- 1. Drum
- 2. Access Cover for Filter
- 3. Access Cover to Hydraulic Valve
- 4. Access Cover to Hydraulic System
- 5. Plug to Check Oil Level
- 6. Plug to Drain Oil

- 7. Tie Rod
- 8. Fill Plug
- 9. Cover for Oil Brake
- 10. Intermediate Shaft Bearing Retainer
- 11. Drum Shaft Bearing Retainer
- 12. Drawbar

- 13. Breather
- 14. Nameplate
- 15. Drawbar Pin
- 16. Bevel Gear Shaft Cover
- 17. Brake Shaft Retainer
- 18. Gearbox

Figure 9 W12E Winch

Optional Equipment (See also Page 32 for details)

The W12E winch may be equipped with the following options:

- Fairlead assembly - To protect wire rope and frame from damage at odd pull angles;

- Alternate gear ratio - To allow better line speed control;
- Extreme duty seals - To allow operation in the most extreme environments;

NOTE: Not all optional equipment listed is available for each model of dozer.

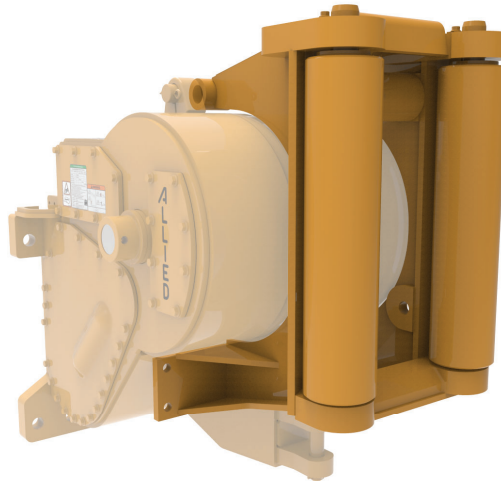
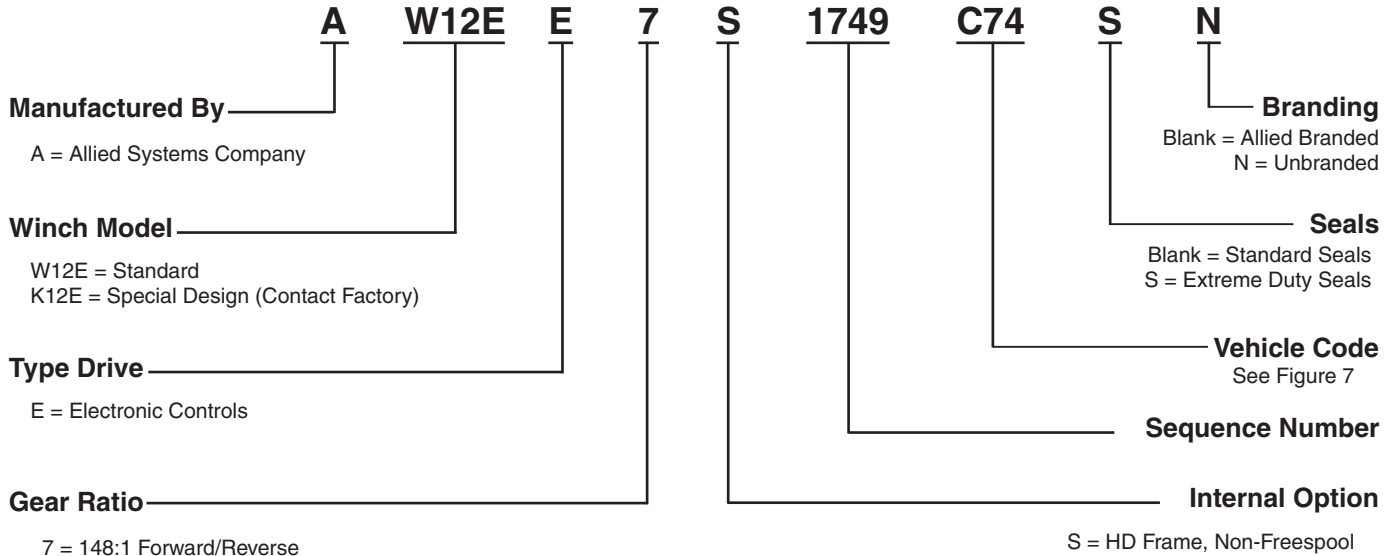

Figure 10 Fairlead (3-Roller Fairlead Shown)

Serial Number Codes

The nameplate with the serial number code is found on the left front corner of the winch case. A serial number indicates the following information:



Note: In Addition to the serial number plate, the serial number is stamped on to the left hand side of the frame.

Vehicle Code	Caterpillar Model and Serial Number Prefix, Where Applicable
C74	D8T, PL83, PL87
C75	D9T
C76	D10T, D10R
C79	587T

Figure 11 Caterpillar Vehicle Codes

Operation

Checks Before Operation

- Check that the wire rope and hook are not worn or damaged.
- Check that the periodic inspection and maintenance have been done at the recommended operating hours. (See Figure 17, Maintenance Schedule.)
- Turn activation switch ON, and check the winch indication light:
 - Light off means winch is ready to work;
 - See Figure 13 for error codes.

Note: The winch oil should be warm (approximately 80°F) prior to operating a winch with a suspended load.

Checks During Operation

- Check the winch indication light:
 - Any blinking indicates a problem.

The Error Codes Chart (Figure 13) identifies issues that may be communicated via the winch indication light. The Troubleshooting Chart (Figure 15) may be used by the operator to identify a problem if the Error Codes chart does not accurately communicate the problem. A trained service person is needed for additional troubleshooting and repair that requires disassembly of parts of the winch.

Operating Procedures

The electronic control lever is connected to the winch through electrical wiring, an electronic control module, and a solenoid actuated control valve. A winch activation switch is installed on the faceplate of the control lever.

When the activation switch is turned **OFF**, the LED will illuminate continuously, and the control lever is disabled. This prevents inadvertent winch operation if the control lever is bumped. The activation switch should be in the **OFF** position unless the winch is being used. When the activation switch is turned **ON**, the LED should be off. If it is blinking, this indicates an error that should be addressed. If there are errors important to winch safety, the winch will remain in the off state even when the switch is in the **ON** position. Refer to error codes in Figure 13 to determine the cause of the error.

This control lever is used to select one of the following operations:

- **BRAKE-OFF**
- **LINE-OUT**
- **BRAKE-ON**
- **LINE-IN**

The **BRAKE-OFF** positions are detented. To return to the **BRAKE-ON** (neutral) position the control lever must be moved back. When using the **LINE-IN** and **LINE-OUT** functions, the control lever will return to the **BRAKE-ON** position when released.



WARNING

Moving the control lever with the engine OFF and the keyswitch ON may result in accumulator discharge and brake release, which will cause loss of load.

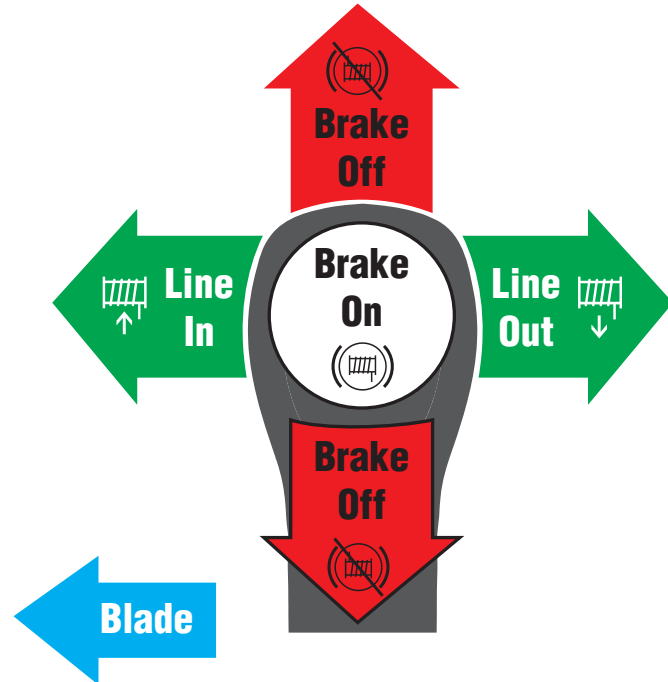
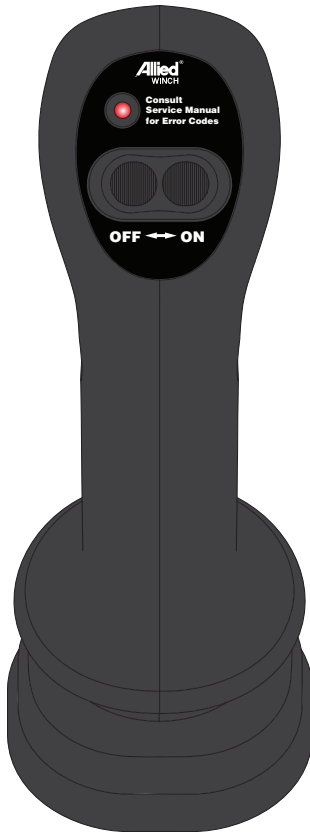

Figure 12 Control Lever

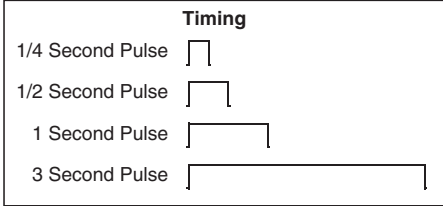
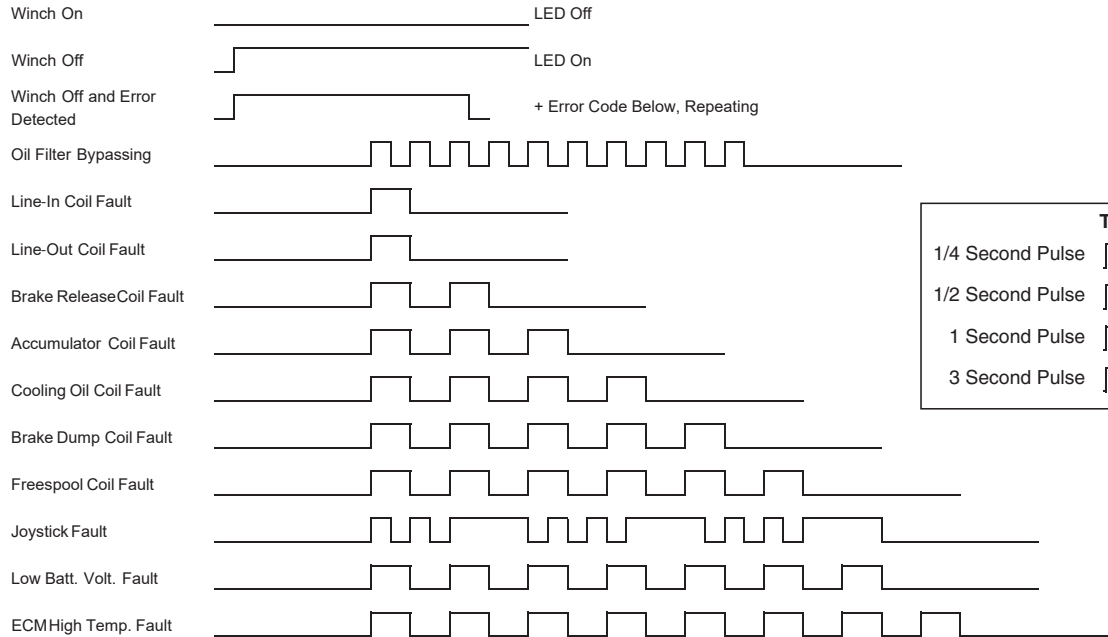
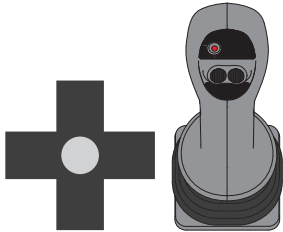

Figure 13 Error Codes

Operation



BRAKE-ON is a neutral position. Neither clutch is applied. The brake is fully applied.

Note: Grey dots represent the positions of the control lever.

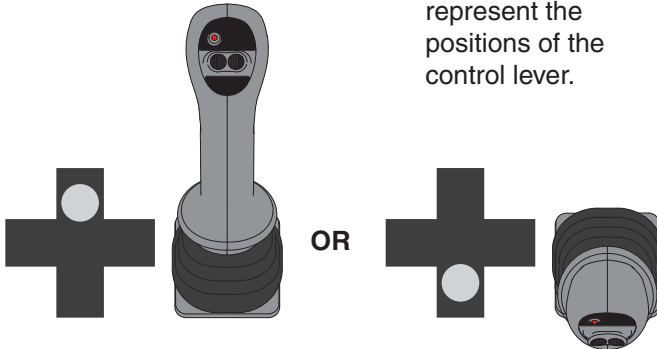

BRAKE-OFF is engaged at two detented positions. Oil pressure has released the brake, but the wire rope cannot be pulled from the winch by hand because of friction in the clutches, brake and gear train. **BRAKE-OFF** is used to move the dozer away from the load while keeping the wire rope tight.

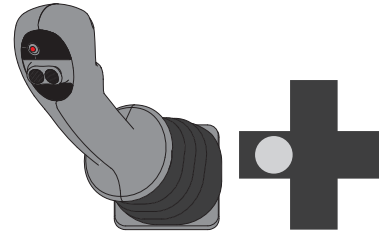

LINE-IN position applies the forward clutch and releases the brake. The winch will wind the wire rope at a speed controlled by the PTO rpm of the dozer and the weight of the load.

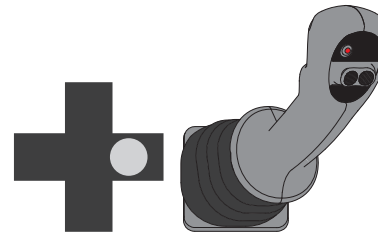

LINE-OUT position applies the reverse clutch and releases the brake. The winch will unwind the wire rope at a speed controlled by the PTO rpm of the dozer and the weight of the load.

Inching is used for fine control of the winch speed. When the control lever is slowly moved to a position between **BRAKE-ON** and **LINE-IN** or between **BRAKE-ON** and **LINE-OUT**, inching occurs. The following paragraphs describe the normal procedures for inching.



CAUTION

Excessive inching will accelerate clutch and brake wear, and cause winch overheating.

Inching (LINE-OUT). This operation is used to slowly move a load away from the dozer. The control valve will cause the oil pressure to slowly release the brake and slowly apply the reverse clutch. As the brake is released, the clutch takes control and begins to move the load.

Inching (LINE-IN). This operation is used to slowly move a load toward the dozer. The control valve will cause the oil pressure to slowly release the brake and slowly apply the forward clutch. As the brake is released, the clutch takes control and begins to move the load.

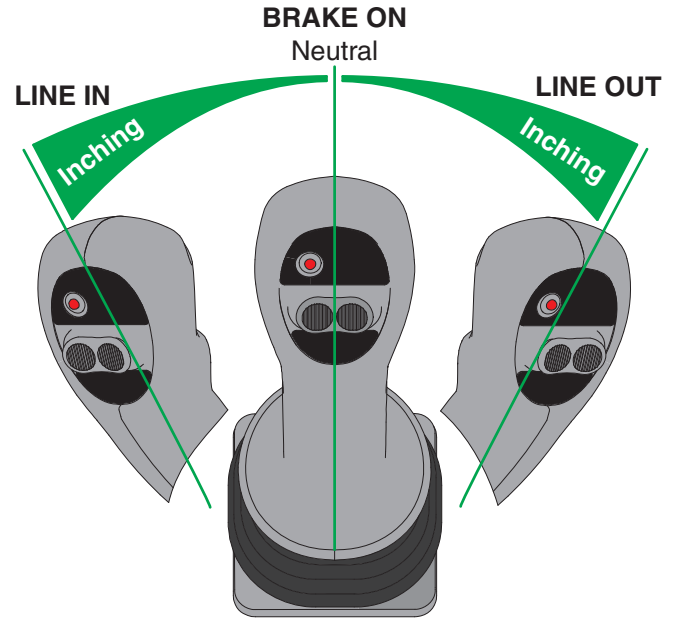

Figure 14 Inching

Troubleshooting Chart

PROBLEM	POSSIBLE CAUSE	CORRECTION
Operation is rough or irregular.	Hydraulic oil is too cold.	Put the control lever in the BRAKE-OFF position. Run the engine at 1000 rpm to warm the oil before operating the winch.
	Low oil level.	Add hydraulic oil to the correct level.
	Low oil pressure.	See the Service Manual for additional troubleshooting.
	Wrong oil.	Drain oil and replace with correct grade. Refer to Figure 7, Recommended Oil List.
Hydraulic oil becomes too hot.	Winch is operated in the BRAKE-OFF position for long periods.	Use the BRAKE-OFF position less. When the BRAKE-OFF position is used, the hydraulic oil flows continuously through the relief valve. See the Service Manual for additional troubleshooting.
	Low oil level.	Add oil.
	Clogged suction strainer/filter.	Check and clean or replace the suction strainer.
	Clutches are dragging.	Check the clutch pressure.
	Defective or improperly adjusted oil relief valve.	See the Service Manual for additional troubleshooting.

Figure 15 Troubleshooting Analysis Chart

PROBLEM	POSSIBLE CAUSE	CORRECTION
Brake begins to release before clutch is applied.	Brake is worn.	See the Service Manual for additional troubleshooting.
Winch brake does not apply or release correctly.	Brake is worn.	See the Service Manual for additional troubleshooting.
	Low oil pressure.	
Clutch does not apply correctly.	Worn or damaged clutch.	See the Service Manual for additional troubleshooting, checks and adjustments.
	Control valve failure.	
	Low oil pressure.	
Clutch does not apply correctly at low PTO rpm.	Accumulator not charged.	Check accumulator.
	PTO stalled (0 rpm).	Increase dozer rpm.
Control lever does not return to BRAKE-ON position when released.	Defective return spring, worn detent parts, or lubricant evacuation.	See the Service Manual for additional troubleshooting.
	Control lever is in detented position (BRAKE-OFF).	Move control lever out of detent.
Winch stalls dozer engine during winch shift when dozer RPM is low.	Not enough engine torque.	Increase engine rpm.
	Low accumulator pressure.	See the Service Manual for additional troubleshooting, checks and adjustments.

Figure 15 Troubleshooting Analysis Chart

PROBLEM	POSSIBLE CAUSE	CORRECTION
Winch will not operate in any function.	Control module not powered.	Check fuse & replace if necessary.
	Control module fault.	Consult error codes in Figure 13.
	Coil open or shorted.	Error code on joystick indicates open or shorted circuit. Check wiring harness continuity. Replace faulty coil. Note: A working coil will have 5 to 35Ω resistance and will be magnetized when energized.
	Cartridge valve plugged.	Replace cartridge if pressure at appropriate gage port is not close to relief pressure with coil energized.
	Loose or worn connector.	Check and replace as needed.
	Relief pressure not being reached.	Check cooling coil & cartridge—replace faulty parts.
	Activation switch off.	Check the switch and turn it on.

Figure 15 Troubleshooting Analysis Chart

PROBLEM	POSSIBLE CAUSE	CORRECTION
Noisy buzz emanating from winch.	Air in relief cartridge.	This is not a detrimental condition. Noise may be intermittent.
Control lever will not detent in BRAKE-OFF .	Detent pin, plate, or spring worn or broken.	Replace control lever.
Winch does not engage and dozer engine draws down in LINE-IN or LINE-OUT .	Plugged brake cartridge.	Replace cartridge.
	Faulty brake coil.	Replace coil.
	Open or shorted brake circuit.	Check wiring harness. See “winch will not operate...” above.
Winch does not engage and/or load rolls out in LINE-IN or LINE-OUT .	Plugged LINE-IN or LINE-OUT cartridge.	Replace cartridge.
	Faulty LINE-IN or LINE-OUT coil.	Replace coil.
	Open or shorted LINE-IN/LINE-OUT circuit.	Check wiring harness. See “winch will not operate...” above.

Figure 15 Troubleshooting Analysis Chart



Maintenance

The Maintenance Schedule is a program that includes periodic inspection and lubrication. Use the operating

time on the hour meter of the dozer to determine the maintenance time for the winch.

Maintenance Points

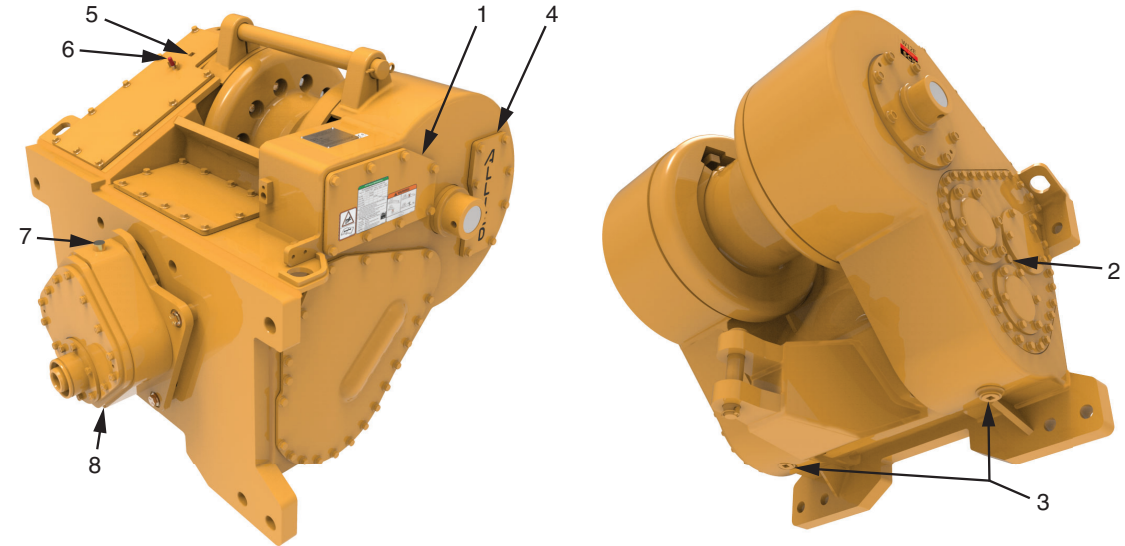

- | | |
|-----------------------------------|--------------------------|
| 1. Access Cover for Control Valve | 5. Fill Plug |
| 2. Plug to Check Oil Level | 6. Breather |
| 3. Plug to Drain Oil | 7. Plug to Fill Gearbox |
| 4. Cover for Filter & Strainer | 8. Plug to Drain Gearbox |

Figure 16 W12E Winch Maintenance Points

Maintenance Schedule

INTERVAL	PROCEDURE OR QUANTITY	SPECIFICATION
50 hours or weekly.	Check oil level at plug (item 2). Add oil as necessary through fill plug (item 5). Do not operate dozer when checking the oil level.	See Figure 7 – Recommended Oil List.
	Check Error Codes for oil filter bypassing. If error code is present with winch warm, replace filter.	Replace the filter.*
	Clean the breather (item 6).	Remove debris around breather.
	Lubricate the rollers on the fairlead assembly, if the winch is so equipped.	Use multi-purpose grease with 2-4% molybdenum disulfide.
500 hours or every 3 months.	Clean the oil suction screen and magnets.*	Use a new gasket between the cover and the suction tube.
	Replace the filter.*	See the Parts Manual for filter element and cover gasket. When replacing, be sure to lubricate filter seal ring between element and filter head.
1000 hours or every 6 months.	Change the hydraulic oil. Drain oil from plug (item 3). Clean the oil strainer. Through fill plug (item 5), add 29 gallons (110 liters) [†] . Check the oil level at item 2.	See Figure 7 – Recommended Oil List.
<p>* NOTE: Clean the oil strainer screen and change the oil filter after the first 250 hours on new and rebuilt winches. [†] Amount of oil may vary slightly with dozer.</p>		

Figure 17 Maintenance Schedule

Operating Techniques

Dozer or Skidder Operation

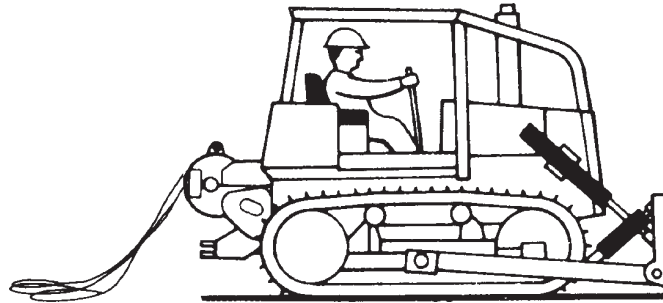
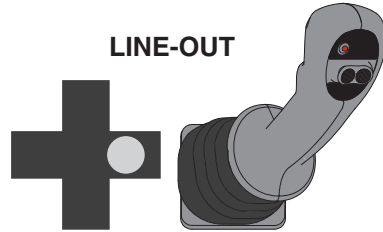

Step 1. The dozer or skidder is moved to an area where a load will be connected. The operator turns on the activation switch, and moves the control lever to the **LINE-OUT** position so that the wire rope can be pulled from the winch drum.

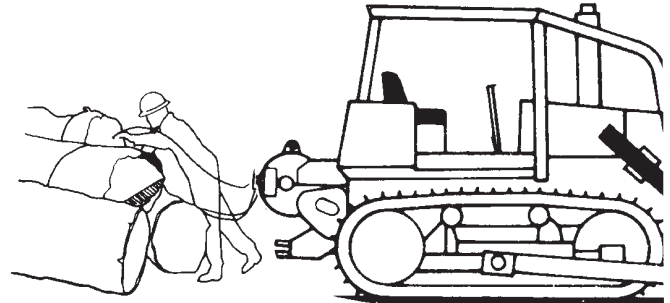
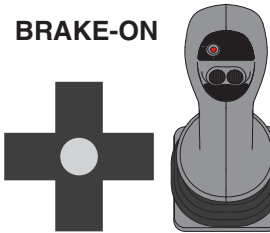

Step 2. A load (logs) is connected to the wire rope. The operator moves the control lever to the **BRAKE-ON** position.

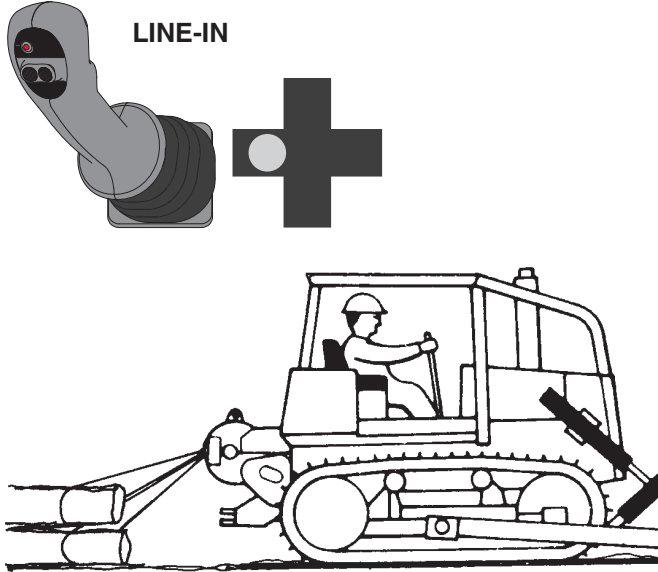

Step 3. The operator can move the control lever to the **LINE-IN** position. If the load is less than approximately 75% of the maximum line pull, the operator can begin traveling with the vehicle at the same time. The winch will wind the load toward the vehicle as it travels. If the load is nearly the capacity of the line pull, the operator must move the load close to the vehicle before beginning to travel.

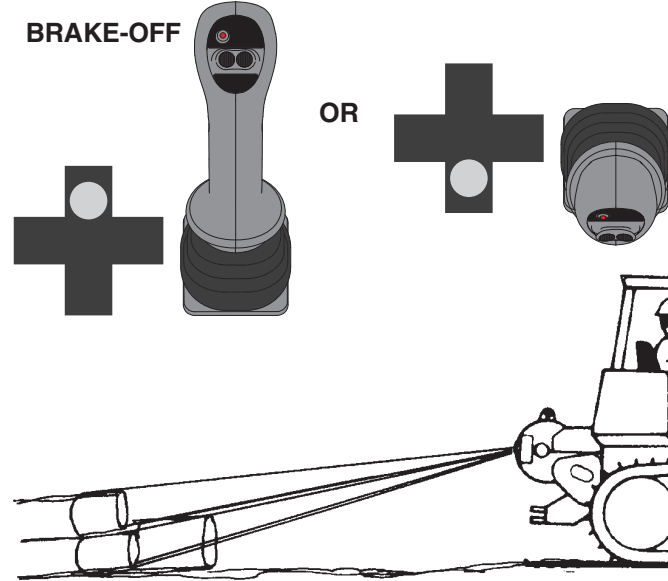

Step 4. If the dozer or skidder must travel through an area with bad traction conditions, the operator can move the control lever to either of the **BRAKE-OFF (DETENT)** positions. This procedure will permit the vehicle to move through the bad traction area while keeping the wire rope tight, but without pulling the load at the same time.

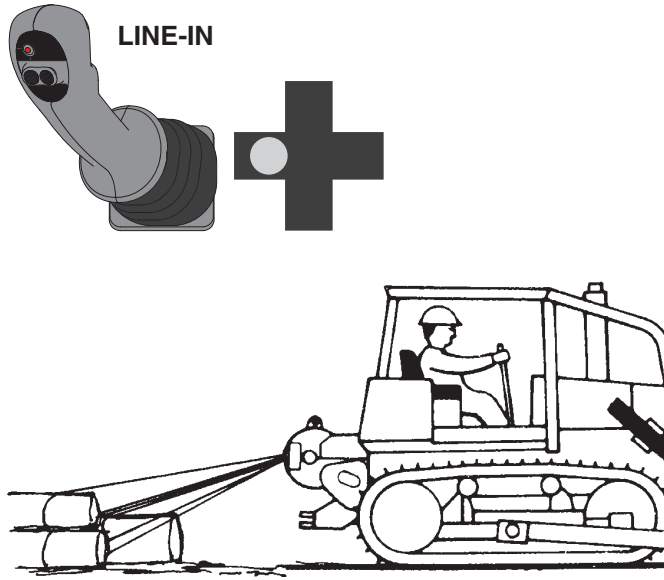

Step 5. When the vehicle is on firm ground, the operator can move the control lever to **LINE-IN** position to pull the load toward the vehicle.

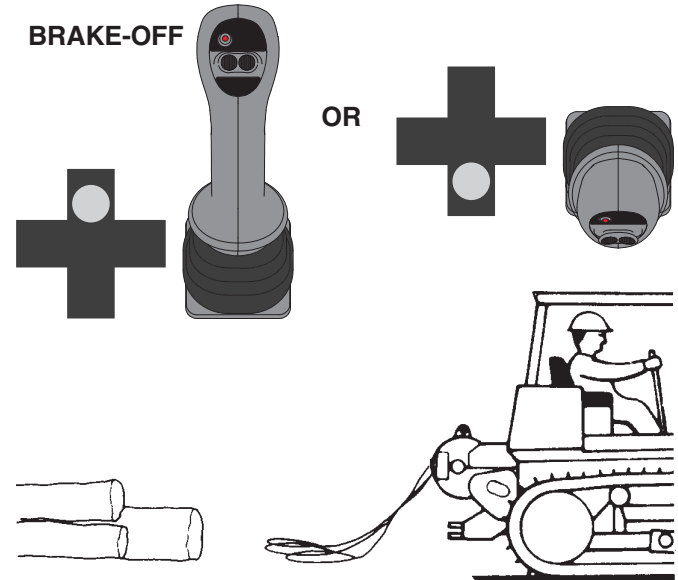

Step 6. When the operator wants to disconnect from the load, the vehicle is stopped and the control lever is moved to the **BRAKE-OFF (DETENT)** position to loosen the wire rope. The wire rope is then disconnected from the load. At the end of the winch usage period, turn off the activation switch.

How to Move a Disabled Vehicle

A. A vehicle equipped with a winch can be used to remove itself from mud or other areas where it cannot move using only the drive wheels or tracks. See Figure 18. Use the following procedure:

1. Fasten the winch wire rope to a structure, tow bar of another vehicle, or a tree that has enough strength for the line pull. The wire rope must be in a direction that is approximately parallel to the direction of travel of the vehicle.
2. Use the throttle to set the engine speed at a power level to operate both the winch and the tracks or drive wheels. (Operator experience is required, because the winch can use most of the engine power in some vehicles.)
3. Put the control lever in the **LINE-IN** position to tighten the winch wire rope. When the winch wire rope is tight, put the vehicle transmission in **REVERSE*** and engage the tracks or drive wheels. Use the power from the engine to the winch and tracks together to remove the vehicle from the bad area.

4. If the vehicle travels faster than the winch winds the wire rope, disengage the transmission until the winch wire rope is tightened again.

*** NOTE: If the tracks or drive wheels on the vehicle stop turning, the torque converter in the transmission has stalled and the winch will stop also. If this happens, put the vehicle in neutral to operate the winch.**

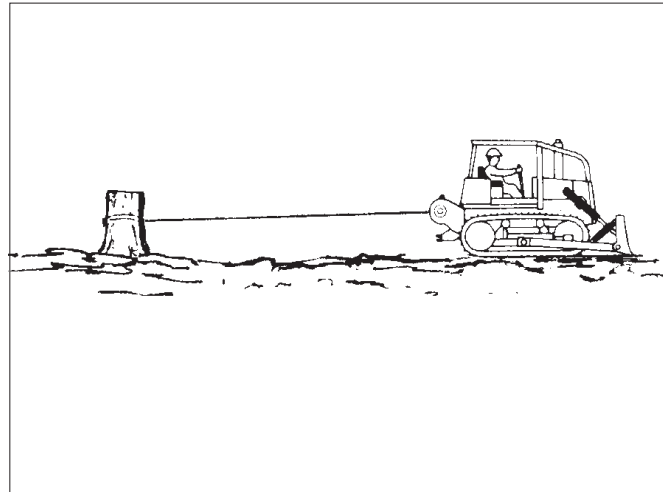

Figure 18 Moving a Disabled Vehicle (Step A)

B. A dozer or skidder equipped with a winch can be used to pull another vehicle from mud or other areas where it cannot move using only the drive wheels or tracks. See Figure 19. Use the following procedure:



WARNING

Use extra care if the traction conditions are bad or if the vehicles are on a slope. Bad traction can cause the disabled vehicle or the dozer to slide. A slope can require additional distance to stop the vehicles.

Make sure the wire rope and tow chain have the capacity to do the job. If the disabled vehicle does not have a tow pin or other equipment for towing, carefully fasten the tow chain around the axle of the disabled vehicle. Make sure the tow chain is fastened so that the chain will not cause injury to people or damage the vehicle.

An operator must be on the disabled vehicle to operate the steering and brakes as it is towed.

1. Fasten the winch wire rope to the tow bar of the other vehicle. The wire rope must be in a direction that is approximately parallel to the direction of travel of the vehicle. Apply the brakes on the dozer or skidder. Use the throttle to set the engine speed at a power level to operate the winch. (Operator experience is required, because the winch can use most of the engine power in some vehicles.)
2. Put the control lever in the **LINE-IN** position to tighten the winch wire rope. When the winch wire rope is tight, use the power from the engine to the winch to pull the vehicle from the bad area. If the disabled vehicle moves under its own power, keep the towing wire rope tight so that the wire rope does not pass under the drive wheels or tracks of the vehicle being towed.

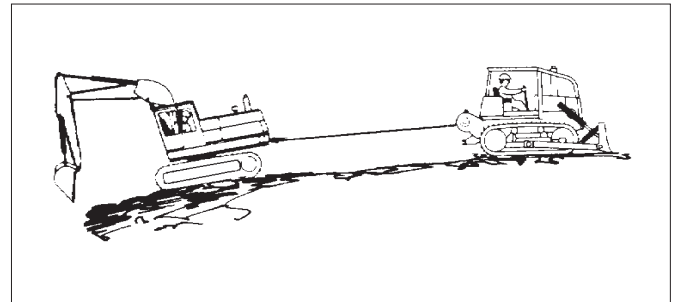

Figure 19 Moving a Disabled Vehicle (Step B)

Working on a Steep Slope



WARNING

Death or equipment loss hazard.

A failure of the dozer, winch, wire rope, or anchor system while working on a steep slope can cause death or personal injury and loss of equipment.

Make sure the winch and the dozer are in good condition for the following procedures, and that all required maintenance has been done. Use only a wire rope that is in good condition. Make sure the wire rope and winch have enough capacity for the load. Make sure the anchor for the wire rope has enough capacity for the load.

Dozer is Down the Slope (See Figure 20).

Sometimes a dozer must work on a steep slope and can use a winch to give assistance when moving on the slope. Fasten the winch wire rope to the drawbar of another

dozer, a structure or a tree that has enough strength to hold the dozer on the slope.

A. Moving down the slope:

1. Set the throttle on the dozer for the required engine speed.
2. Put the dozer in **FORWARD**. At the same time, move the winch control lever to a position between **BRAKE-ON** and **LINE-OUT** (inching) to control the speed of the dozer down the slope.

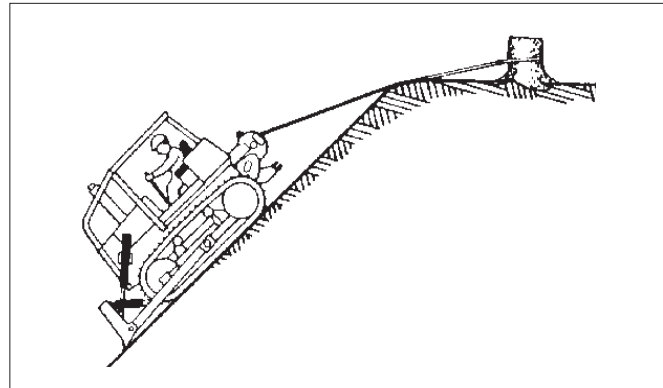

Figure 20 Working on a Steep Slope

Operating Techniques, General

B. Moving up the slope:

1. Set the throttle on the dozer for the required engine speed.
2. Use the **LINE-IN** control lever to tighten the winch wire rope. When the winch wire rope is tight, put the dozer transmission in the **FIRST** speed range and **REVERSE** and engage the tracks or drive wheels. At the same time, move the control lever on the winch to **LINE-IN** position.
3. Use the steering on the dozer to keep the travel of the dozer in line with the winch wire rope.
4. Fully engage the **LINE-IN** clutch as necessary, and use minimal inching to prevent additional heat and wear. Do not permit the winch wire rope to loosen and pass under the drive wheels or tracks of the dozer.

Other Equipment is Down the Slope (See Figure 21).

In this operation, the dozer and winch are on stable ground and other equipment is working on a steep slope. The winch is used to give additional control to the equipment working on the steep slope. A winch with a fairlead option is recommended for this operation if alignment of the other equipment with the winch and dozer is a problem.

Make sure the dozer and winch are on stable ground and will not slide when the load is applied. Align the dozer and winch with the load. Apply the parking brake on the dozer.

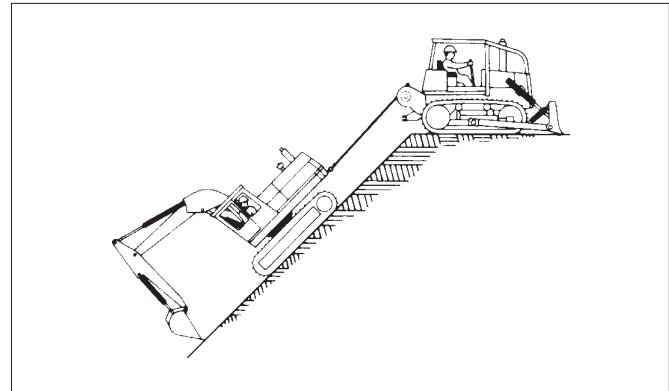

Figure 21 Other Equipment on a Steep Slope



A. Lowering the equipment on the slope:

1. Set the throttle on the dozer for the required engine speed. Operator experience is required for this operation so that the load is carefully controlled.
2. Keep the winch wire rope tightened between the dozer and the equipment being lowered down the slope. Use the control lever in the **LINE-OUT** position to control the lowering of the equipment down the slope.
3. Move the control lever between **LINE-OUT** and **BRAKE-ON** positions if inching is required. Use minimum inching to prevent additional heat and wear.

B. Raising the equipment on the slope:

1. Set the throttle on the dozer for the required engine speed. Operator experience is required for this operation so that the load is carefully controlled.
2. Keep the winch wire rope tightened between the dozer and the equipment being raised up the slope. Use the control lever in the **LINE-IN** position to control the raising of the equipment up the slope.
3. Move the control lever between **LINE-IN** and **BRAKE-ON** positions if inching is required. Use minimal inching to prevent additional heat and wear.
4. Keep the equipment being raised in alignment with the winch and dozer. Do not permit the winch wire rope to loosen and pass under the drive wheels or tracks of the dozer.

Operational Differences, Optional Equipment

Operational Differences, Optional Equipment

Fairlead

A fairlead consists of a set of top and bottom horizontal rollers and side rollers that the wire rope is fed through. With this attachment, if the direction of line pull is not within the small window of the fairlead, then the wire rope is pulled across one of the fairlead rollers instead of across the frame, thus protecting both the frame and the wire rope from excessive wear.

Stability of the dozer is affected somewhat by the fact that the fairlead rollers are more rearward than the drum, thus putting slightly more moment on the dozer during side pulls. The operator must take care to assure stability on slopes.

Drawbar

Do not use the drawbar as an anchor point for a two-part line from the winch. Loads applied to the drawbar are transmitted to the bolts holding the winch to the dozer. Drawbars are designed to handle pulls of 66% of winch rated capacity.

Optional Gear Ratios

Lower speed ratios allow better operator control of line speed. They may also allow the winch to pull in excess of wire rope or winch rated capacity. They do not increase the durability or damaging load limit of the winch. Line pulls in excess of rated capacity will dramatically reduce the life of winch components.



Notes

NO MATTER HOW YOU SAY IT ...

La Prudence Paye
La Seguridad Paga
Betriebssicherheit Macht Sich Bezahlt
Passaa Olla Huolellinen
Veiligheid Voor Alles
Säkerhet Först
Essere Sicuro Paga
Segurança Paga
Sikkerhet Først
Pinter Be Awas

सावधान और रिहा रहौ ।

في التآني السومة

安全第一



SAFETY PAYS!

SAFETY PAYS!



® To find a dealer in your area,
Call: 503.625.2560,
Fax: 503.625.7269, or
Email: marketing@alliedsystems.com, or
Visit our website: www.alliedsystems.com



599012W-CAT 01/29/2024 Printed in U.S.A.