

Operating Manual



H5C

Hydraulic Winch

This manual must be with the vehicle
on which this winch is installed.

Please check the Allied Systems website
regularly for updates to this manual.
www.alliedsystems.com

A Product of
Allied Systems
COMPANY
Sherwood, OR USA

P/N 599070W

Printed in U.S.A.

08/19/2024

Foreword

The safe and efficient operation of a winch requires skill and alertness on the part of the operator. To develop the skills required, the operator must:

- Receive training in the proper operation of the winch and the machine on which it is mounted.
- Understand the capabilities and limitations of the winch and the machine on which it is mounted.
- Become familiar with the winch and the machine on which it is mounted and see that they are maintained in good condition.
- Read and understand the SAFETY SUMMARY and OPERATING PROCEDURES contained in this Operating Manual.

In addition, a qualified person experienced in the operation of the winch must guide a new operator through several load handling applications before the new operator attempts to operate the equipment alone. It is the employer's responsibility to make sure that the operator can see, hear, and has the physical and mental ability to operate the equipment safely.

This operating manual contains basic information necessary for the operation and maintenance of a winch. Optional equipment is sometimes installed that can change the characteristics described in this manual. Make sure the necessary instructions are available and understood before operating the winch.

Some of the components described in this Operating Manual will NOT be installed on your winch. If you have questions about any item on your winch or described in this operating manual, contact your local winch dealer, or contact Allied Systems Company:

Allied Systems Company
21433 SW Oregon Street
Sherwood, OR 97140 USA

Phone: 503-625-2560

Fax: 503-625-7269

E-Mail: marketing@alliedsystems.com

Also visit our website, www.alliedsystems.com, where the most current copy of this manual is always available.

Note: For repairs and overhaul, contact your Allied winch dealer. If you maintain your own equipment, a service manual is available for your specific winch.

Note: This publication may be translated to different languages for sole purpose of easy reference in non-English speaking locations. Should there be differences in interpretations to the text, please refer to the English language edition published by Allied Systems Company as the controlling document.

Contents

Foreword	i
Contents	iii
Safety Summary	v
GENERAL	
Introduction.....	1
How Winches Operate.....	1
Nameplate	3
Wire Rope Selection.....	4
Wire Rope Reel.....	6
Wire Rope Installation	7
Oil Selection	9
Oil Capacity	9
H5C Winch Descriptions	10
Optional Equipment.....	11
Serial Number Codes.....	12

OPERATION	
Checks Before Operation	14
Checks During Operation.....	14
Operating Procedures.....	15
LINE-IN.....	15
LINE-OUT.....	15
SWITCHES (All except Y46)	16
FREESPOOL.....	16
HI-SPEED.....	17
SWITCHES (Y46 installations).....	18
WINCH OFF / WINCH ON / FREESPOOL.....	18
BRAKE-OFF	19
HI-SPEED.....	20
FREESPOOL Drag Adjustment.....	21

MAINTENANCE	
Maintenance Points	22
Maintenance Schedule.....	23
Troubleshooting Chart	24

Contents (Continued)

OPERATING TECHNIQUES

Dozer or Skidder Operation	25
How to Move a Disabled Vehicle.....	28
Working on a Steep Slope	30
Dozer is Down the Slope	30
Other Equipment is Down the Slope	31

OPERATIONAL DIFFERENCES, OPTIONAL EQUIPMENT

Integral Arch	33
Fairlead.....	33
Drawbar	34
Optional Gear Ratios.....	34

Safety Summary

General Safety Notices

The following pages contain general safety warnings which supplement specific warnings and cautions appearing elsewhere in this manual. All electrical and hydraulic equipment is dangerous. You must thoroughly review and understand the Safety Summary before attempting to operate, troubleshoot or service this winch.

The following symbols/terms are used to emphasize safety precautions and notices in this manual:

 **DANGER**

The “DANGER” symbol indicates a hazardous situation which, if not avoided, will result in death or serious injury. Carefully read the message that follows to prevent serious injury or death.

 **WARNING**

The “WARNING” symbol appears wherever incorrect operating procedures or practices could cause serious injury or death. Carefully read the message that follows to prevent serious injury or death.

 **CAUTION**

The “CAUTION” symbol appears where a hazardous situation which, if not avoided, could result in minor to moderate injury and equipment damage.

NOTICE

This signal word alerts to a situation that is not related to personal injury but may cause equipment damage.

NOTE: ...

The term “NOTE” highlights operating procedures or practices that may improve equipment reliability and/or personnel performance.

Safety Regulations

Each country has its own safety legislation. Know and understand these regulations and comply with them in full. This also applies to local bylaws and regulations in force on a particular worksite.

Should the recommendations in this manual deviate from those in the users’ country, the national regulations should be followed.

NOTE: All possible safety hazards cannot be foreseen so as to be included in this manual. Therefore, you must always be alert to potential hazards that could endanger personnel and/or damage the equipment.



WARNING

The winch shall not be used for hoisting.



WARNING

Use hearing protection when operating winches.



WARNING

Maximum winch system permissible pressure and flow:

650 PSI - Control Pressure

3,500 PSI / 55 GPM - Working Pressure.

Operation, Inspection, and Maintenance Warnings



Obey the following cautions and warnings before using your winch, to avoid equipment damage, personal injury or death.

- Do not operate the winch unless you are authorized and trained to do so.
 - Do not operate the winch unless the vehicle is equipped with a screen to protect the operator if the wire rope breaks.
 - Read, understand, and follow the operating, inspection, and maintenance instructions in this Operating Manual.
 - Do not use the control levers for hand holds when entering or leaving the vehicle.
 - Do not permit other people near the control area when you inspect or repair a machine.
 - Never inspect, repair, or perform maintenance on a machine that is in motion.
- Inspect the winch before each use:
 - » Make sure that the controls and instruments operate correctly.
 - » Report the need for repairs immediately.
 - » Do not work with a damaged or worn wire rope.
 - » Do not use a winch that needs repairs.
 - » If the wire rope and ferrule must be removed from the drum, make sure the end of the wire rope and ferrule are controlled when the ferrule is released. The end of the wire rope can suddenly move from the drum like a compressed spring when the ferrule is released and cause an injury.
 - Stay in the operator's seat when operating the winch.
 - Do not stand on the vehicle when operating the winch.
 - Avoid winch operation near people or other machines.

- Never stand nor permit others to stand in the bight (loop) of a wire rope.
- Do not stand nor permit others to be near the winch or wire rope when there is tension on the wire rope.
- Observe jobsite rules.
- Be in complete control at all times.
- Do not use the control levers as hangers for clothes, water bags, grease guns, lunch pails, etc.
- Do not leave the vehicle when the winch wire rope is under tension.
- Do not permit riders on the vehicle or load.
- Do not use the winch as an anchor for a double or two-part line.
- Do not pull the hook through the throat or over the drum, which will cause damage.
- When the winch is not in use, make sure the control lever is in **BRAKE-ON** position and the winch brake is applied.

- Do not use winch as a hoist. Dozer and skidder mounted winches are designed for towing.

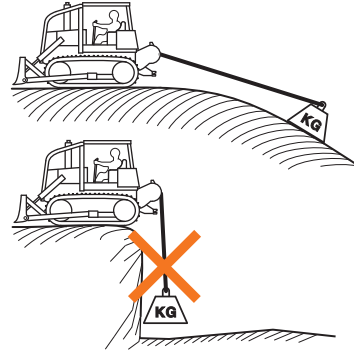

- Always inspect wire rope, tail chain and other rigging components for wear, damage, broken strands or abuse before use.
- Never use wire rope, tail chain or other rigging that is worn-out, damaged or abused.
- Never overload wire rope, tail chain or rigging.

Safety Summary

- Wire rope and tail chain will fail if worn-out, overloaded, misused, damaged, improperly maintained or abused. Wire rope or tail chain failure may cause serious injury or death!



- Do not terminate wire rope to tail chain by the use of a knot.
- Do not handle wire rope if the hook end is not free. A load could break away, suddenly tensioning the wire rope, resulting in serious injury or death.
- Stay clear of wire rope entry areas (fairlead or arch rollers, winch drum etc).

- Make sure ground personnel are in plain view of the operator, and at a distance of at least 1½ times the working length of the wire rope.
- Make sure that any hand signals used by ground personnel are clearly defined and understood by everyone involved.
- Do not attempt to “jerk” or “shock” a load free. Doing so can cause loads in excess of the rated capacity of the wire rope, winch, or mounting hardware.
- Replace any parts only with genuine Allied Winch parts. Refer to Parts Manual 599029W.
- Maintain **a minimum of three (3) complete wraps of wire rope** on the drum for normal operation. It may help to paint the last five wraps of wire rope a contrasting color, to serve as a visual indicator.
- Do not handle wire rope with bare hands. Wear leather gloves at all times.
- Align the dozer with the load to prevent side loading the winch, and to maintain even spooling of the wire rope.

- If applying tension to the wire rope manually during spooling:
 - » ensure that the operator is winching in slowly,
 - » keep your hands and clothing well clear of any rollers or the winch drum,
 - » do not maintain tension by letting the wire rope to slip through your hands,
 - » use a hand-over-hand technique to maintain tension.
- Be aware of the ground conditions, and make sure the ground and dozer are stable enough to pull the intended load.
- Do not attempt to pull loads in excess of the rated capacity of the winch.
- Keep yourself informed of any applicable codes, regulations and standards for the job.
- Your winch may have temperature shut-off system for protection of dozer and winch. Manual override of high temperature shut-off will cause damage to dozer and winch.
- This winch is neither intended, designed, nor rated for any application involved in the lifting or moving of personnel.
- Use only the lubricants listed in the Oil Specifications. See Page 9.
- Do not weld on any part of the winch. Contact Allied Systems if weld repairs are needed.
- The hydraulic system must be kept clean and free of contamination at all times.

Safety Summary

- Be aware of the hazards of pressurized hydraulics:
 - » Wear personal protective equipment, such as gloves and safety glasses, whenever servicing or checking a hydraulic system.
 - » Assume that all hydraulic hoses and components are pressurized. Relieve all hydraulic pressure before disconnecting any hydraulic line.
 - » Never try to stop or check for a hydraulic leak with any part of your body; use a piece of cardboard to check for hydraulic leaks.
 - » Small hydraulic hose leaks are extremely dangerous, and can inject hydraulic oil under the skin, even through gloves.
 - » Infection and gangrene are possible when hydraulic oil penetrates the skin. See a doctor immediately to prevent loss of limb or death.



Product Modifications

- Any alterations to the winch that have not been approved by Allied Systems Company, or use of any non-OEM replacement parts, will void the warranty, and may introduce serious safety hazards.
- Any non-OEM parts used, or any alterations made are done so at your own risk to personnel safety. This includes the addition of accessories and attachments not manufactured or approved by Allied Systems Company.

Notes

General

Introduction

This operating manual contains basic information necessary for the operation and maintenance of the H5C winch.

How Winches Operate

Operating Principles

A winch is normally installed on a skidder or dozer to:

- increase the pulling power of the skidder or dozer.
- reach into an area where a skidder or dozer cannot go.
- make lift functions available when special attachments are installed.

The winch is powered by an internal hydraulic motor connected to the dozer hydraulic system. Oil flow and pressure are converted to rotational energy by the winch motor. Torque is transmitted through a holding brake, and

three gear reductions to the drum. Hydraulic oil is supplied by the dozer mounted pump. The winch utilizes oil, filtration and cooling provided by the dozer circuit. Power to the winch is controlled by a control lever and electrical switches located at the dozer's control station.

The dozer must be running, and the auxiliary hydraulic function switch, if equipped, must be on. **LINE-IN, LINE-OUT** and **BRAKE-ON** are controlled by a proportional control lever. When the control lever is in the **BRAKE-ON** or centered position, the holding brake is automatically applied. Pushing the lever away from the operator releases the brake and reels wire rope off the drum (**LINE-OUT**). Pulling the lever towards the operator releases the brake and reels wire rope onto the drum (**LINE-IN**). Releasing the lever causes it to return to the **BRAKE-ON** position, which stops the drum rotation and applies the holding brake. Moving the lever a small amount results in slow wire rope movement for inching control. Line speed increases proportionally as the lever is moved farther.

The switch panel may contain up to three rocker switches to control **FREESPOOL**, **BRAKE-OFF**, and **HI-SPEED**. Not every winch is equipped with all three. See page 16 and page 18 for detailed views of these switches and descriptions of their operation.

The dozer must be running to supply hydraulic power to operate these functions.



WARNING

FREESPOOL should not be used if there is a load on the wire rope. An uncontrolled release of the load will occur. Loss of the load can result in injury and/or equipment damage.

When **FREESPOOL** is selected, a hydraulically-actuated sleeve disengages the drum pinion from the intermediate shaft. The drum is now disconnected from the brake, and the winch cannot support a load. On some installations, the control lever will still operate the winch motor, but the drum will not turn.

When the **BRAKE-OFF** switch is depressed, the brake-off clutch is disengaged, allowing the dozer to move away from a towed load.

Pushing the **HI-SPEED** switch towards the operator allows the winch to operate at low speed, while pushing the switch away from the operator activates **HI-SPEED**. When in **HI-SPEED** mode, the winch will automatically shift to low speed when the load exceeds a certain percentage of the rated load. For heavy loads or when better control is desired, the winch should be operated in the normal speed. For light loads and faster wire rope speed, operate the winch in **HI-SPEED** mode.

Nameplate

Each winch is shipped from the factory with a nameplate as shown in Figure 1. The nameplate is stamped with:

- winch model
- winch serial number
- maximum rated bare drum line pull
- maximum wire rope diameter

DO NOT operate the winch with larger diameter wire rope. If the nameplate is missing, DO NOT operate the winch until its capacity is known.

The serial number for the winch is also stamped into the frame next to the nameplate.

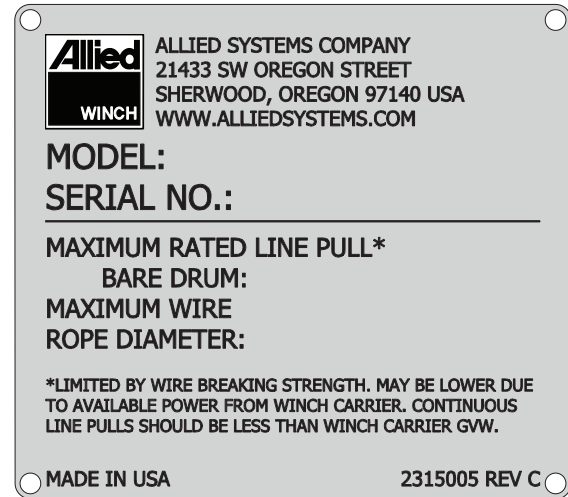

Figure 1 Nameplate

Wire Rope Selection

Each winch model can have a variety of wire rope sizes, lengths, or grades installed by the user. The maximum wire rope size is shown on the nameplate. The maximum rated line pull stamped into the nameplate is based on the maximum wire rope size, EEIPS grade. When a smaller diameter wire rope, or a different grade is installed, the line pull is limited by the capacity of the wire rope.

See Figure 2 for approved wire rope sizes, drum capacities and maximum rated line pulls. When a larger diameter wire rope is used, the length of wire rope installed on the drum will be shorter. Be aware that the winch can create a tension in the wire rope that is greater than the strength of the wire rope. The user must be careful to select a wire rope that has enough strength and length for the job.

WARNING

Load loss hazard.

A wire rope that breaks under high tension can suddenly whip back towards the winch, causing injury or product damage.

Be sure the operator knows the capacity of the wire rope and the winch.

WARNING

Load loss hazard.

A loaded wire rope with fewer than three complete wraps on the drum could disengage from the ferrule pocket, causing load loss and possible injury.

Paint the last five wraps of wire rope a contrasting color to alert the operator that end of the wire rope has been reached.

Wire Rope Diameter in (mm)	Capacity for Full Drum Fill ft (m)	Capacity for 2/3 Drum Fill ft (m)	EIPS Maximum Rated Line Pull Lbs (N)	EEIPS Maximum Rated Line Pull Lbs (N)
5/8 (16)	423 (129)	279 (85)	29,400 (130,700)	32,400 (144,100)
3/4 (19)	298 (91)	197 (60)	42,000 (186,800)	46,200 (205,500)
7/8 (22) ^{*4}	215 (66)	142 (43)	56,800 (252,600)	62,500 (278,000)
<p>NOTE:</p> <ol style="list-style-type: none"> Loosely or unevenly spooled line will reduce capacities. Use flexible wire rope with independent wire rope center. Ferule size: 2 inches diameter, 2 1/4 inches long. If your winch is equipped with the optional arch, the largest wire rope diameter approved for use is 3/4 inch. 				

Figure 2 Wire Rope Sizes and Capacities

Wire Rope Reel

When the wire rope is transferred from a reel to the drum, or from the drum back onto a reel, it must go from “top to top” for overwind winches, or “bottom to bottom” for underwind winches, as shown in Figure 3, to avoid putting a reverse bend into the wire rope.

Overwind Winches

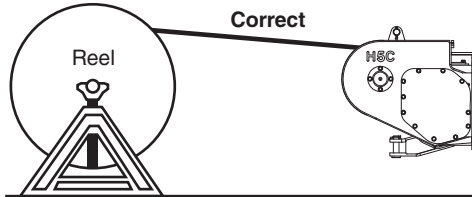
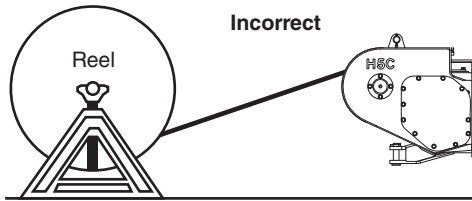

Reel from top to top.

Underwind Winches

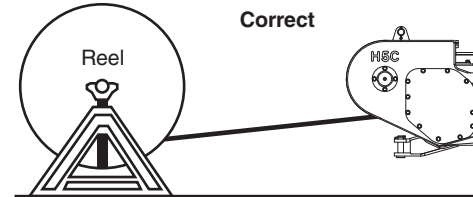
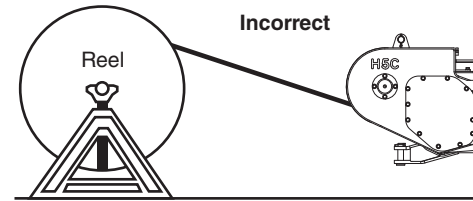

Reel from bottom to bottom.

Figure 3 Transferring Wire Rope from or to Reel

Wire Rope Installation



WARNING

Gloves should be worn when working with or near wire rope to prevent cuts and abrasions.

NOTE: The illustrations in this section show a winch with an “overwind” configuration, which is standard. Some winches are configured for “underwind”, with the wire rope spooling onto the bottom of the drum instead of the top. The procedures for installation are the same.

Seat the ferrule on the drum end of the wire rope in the ferrule pocket in the drum. See Figure 4. Use the keeper and related hardware to secure the ferrule. Torque the capscrew to 28-29 ft-lbs.

Once the ferrule is properly secured in the pocket, the wire rope may be spooled slowly onto the drum. Apply enough tension to the wire rope as it is being spooled to ensure that it spools neatly and tightly on the drum.

Tension may be created by a variety of methods. The methods described here are not exclusive.

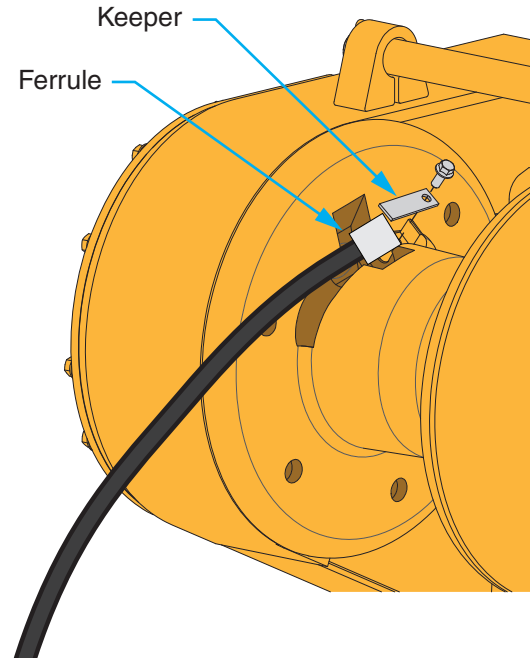

Figure 4 Secure Ferrule in Pocket with Keeper

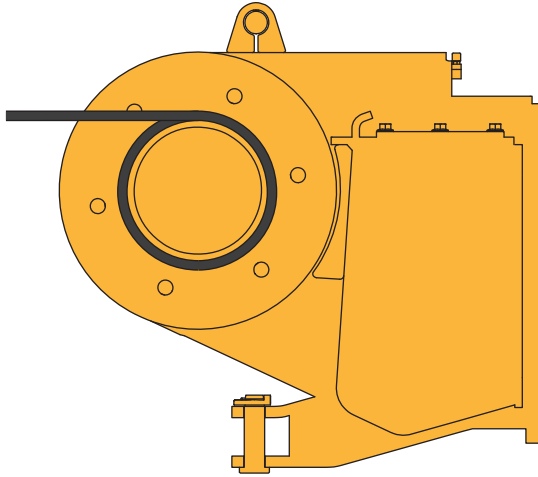
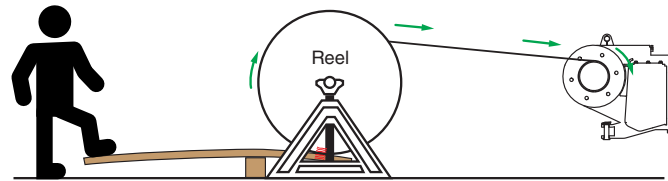

Figure 5 First Layer, Overwind Configuration

One method is to create a wooden plank lever, as shown in Figure 6 to apply pressure to the reel flange(s). The friction between the wooden plank and the reel flange(s) will create resistance to rotation of the reel, which will create tension in the wire rope as it is slowly spooled onto the winch drum.

Another method is to use the tines of a forklift to bear against the reel flange(s). Again, the friction generated between the tines and the flange(s) will create tension in the wire rope.

Finally, the end of the wire rope may be fastened to a forklift. The forklift may be driven away from the winch drum as the wire rope is paid out, and the forklift operator may use the brake on the forklift to provide tension on wire rope as the wire rope is spooled back onto the winch drum. The movement of the forklift and the paying out or spooling back onto the winch drum shall be coordinated to prevent the wire rope from contacting the ground.



Apply pressure to reel flange(s).

Figure 6 Create Tension

Oil Selection

The main consideration while selecting hydraulic fluid is the estimated oil temperature extremes that will be experienced during service so the most suitable temperature-viscosity characteristics are obtained.

Oil Capacity

The oil capacity for H5C winch is 17 quarts (16 liters).

Recommended Oils* - General Conditions			
Manufacturer	Oil Type	Ambient Temperature Range	
		°F	°C
ExxonMobil	Mobil Fluid 424 (Factory fill)	-13 to 104	-25 to 40
John Deere	Hy-Gard™	-13 to 122	-25 to 50
Chevron	1000 THF	-13 to 104	-25 to 40
Caterpillar	Multipurpose Tractor Oil (MTO)	-13 to 104	-25 to 40
Case	Hy-Tran Ultra	-20 to 122	-29 to 50

Recommended Oils* - Low Temperature Conditions			
Manufacturer	Oil Type	Ambient Temperature Range	
		°F	°C
ExxonMobil	Mobil Fluid LT	-40 to 86	-40 to 30
John Deere	Low Viscosity Hy-Gard	-40 to 86	-40 to 30
Chevron	THF W	-40 to 86	-40 to 30

* Note: Use of a non-recommended oil may void warranty.

** For winches using tractor-supplied hydraulics for winch operation, recommended oil is used only in the winch gear case.

Figure 7 Recommended Oil List

H5C Winch Descriptions

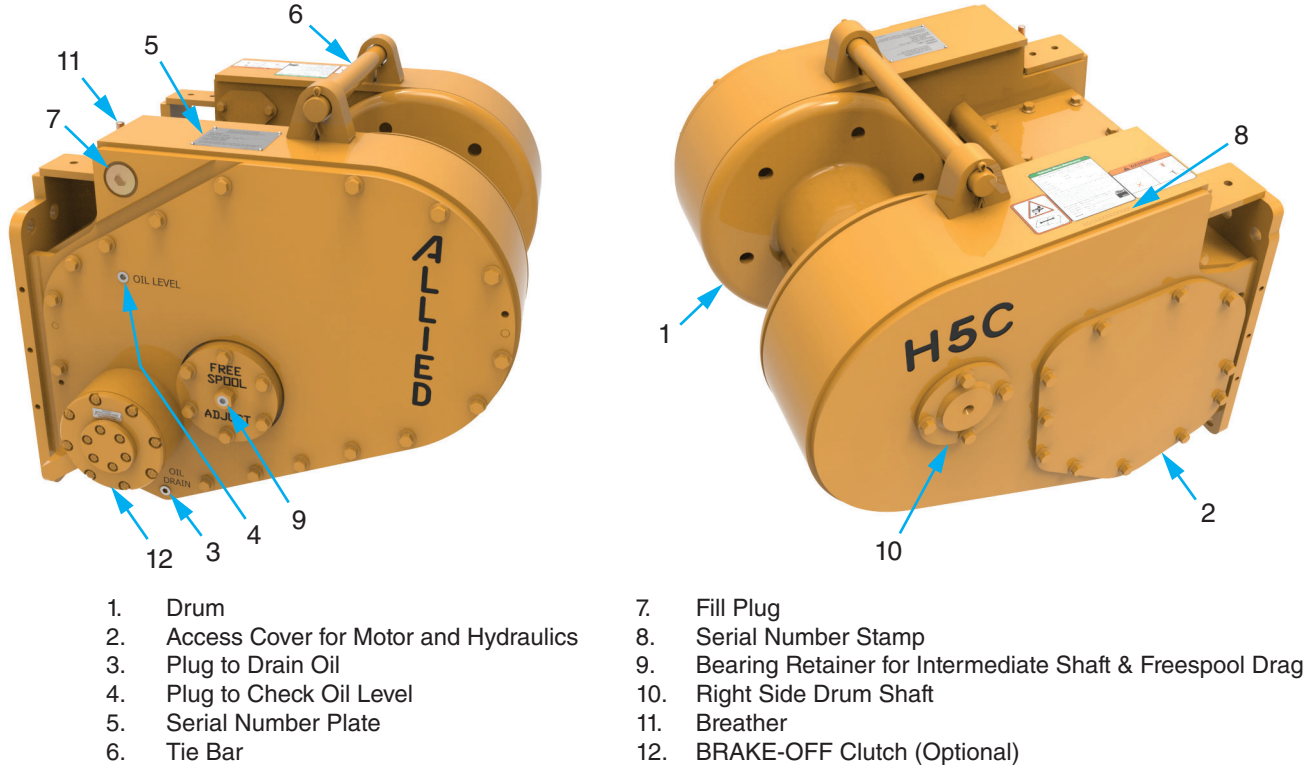

Figure 8 H5C Hydraulic Winch

Optional Equipment

The H5C winch may be equipped with the following options:

- Integral arch*
- Fairlead
- Heavy duty extended drawbar

NOTE: Not all optional equipment listed is available for each model of dozer.

* When the winch is fitted with an arch, wire rope diameter shall be reduced one size from maximum recommended wire rope diameter.

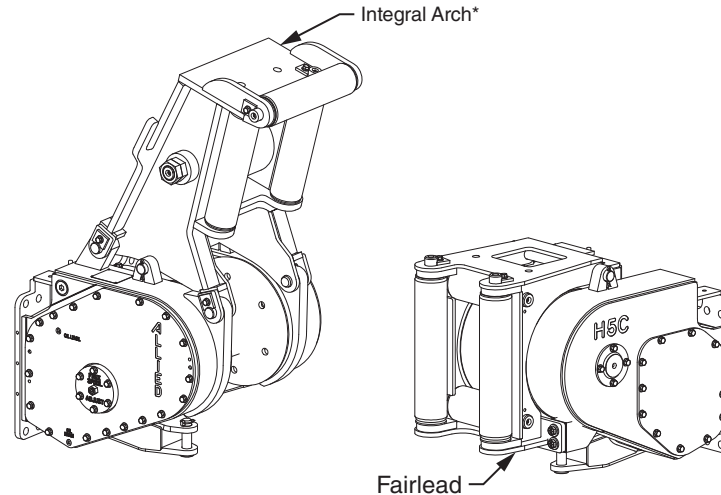
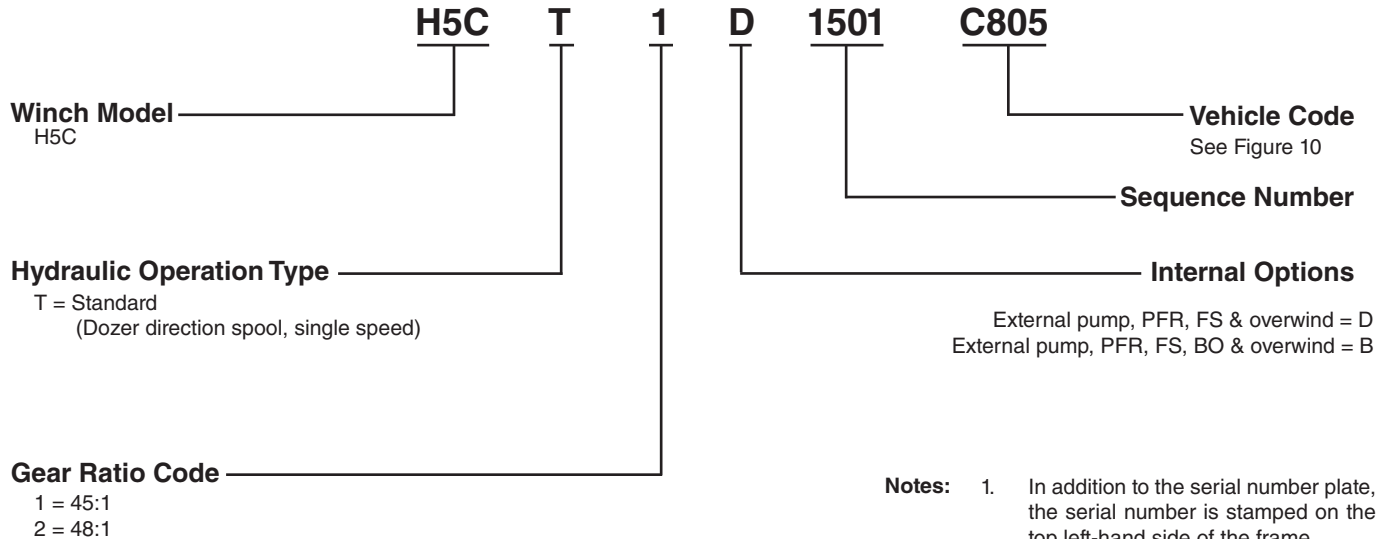

Figure 9 Optional Equipment



Serial Number Codes

The nameplate with the serial number code is found on the left front corner of the winch case. A serial number indicates the following information:



- Notes:**
1. In addition to the serial number plate, the serial number is stamped on the top left-hand side of the frame.
 2. Circled numbers in Figure 10 indicate possible gear ratios.

Dozer Make Model

C O D E	C Caterpillar	K Komatsu	L Liebherr	R Case	Y TCi
371		D51-24 ②		1150M ②	
39			PR716 ②		
42				1650M ②	
46					920 ②
805	D6K2 T4F ①				
806	D4 BUILD 16A ①				

Figure 10 Dozer or Skidder Identification Codes and Available Gear Ratios for H5C Winch

Operation

Checks Before Operation

Check the wire rope and hook for wear or damage. Check that the periodic inspection and maintenance have been done at the recommended operating hours. See the Maintenance Schedule, Figure 16 on page 23.

Checks During Operation

The Troubleshooting Chart, Figure 17 on page 24 can be used by the operator to identify a problem with the winch operation. A trained service person is needed for additional troubleshooting and repair that requires disassembly of parts of the winch.

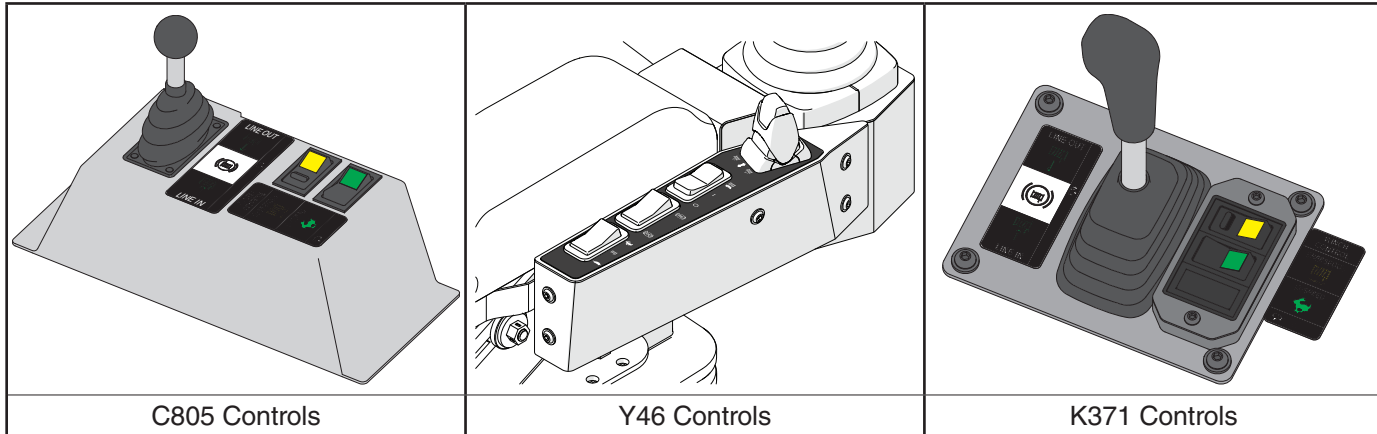

Figure 11 H5C Hydraulic Winch Operator Controls (Typical...Your Installation May Vary)

Operating Procedures

The H5C winch is designed to operate on a load sense, pilot-operated hydraulic system. When the dozer is running, the winch is ready to operate but no oil is flowing to the winch. Pilot pressure is present at the winch.

The control lever and electrical switches are used to select the following operations (not all winches are equipped with all options):

- **BRAKE-ON** (spring-centered position)
- **LINE-IN**
- **LINE-OUT**
- **FREESPOOL**
- **HI-SPEED** (either **LINE-IN** or **LINE-OUT**) (optional)
- **BRAKE-OFF** (optional)

The dozer-mounted lever controls **LINE-IN**, **LINE-OUT** and **BRAKE-ON** functions. When the lever is in the neutral or spring-centered position, the winch is in **BRAKE-ON** mode. In the **BRAKE-ON** position, no oil is directed to the motor and the spring-applied holding brake prevents drum movement, unless **BRAKE-OFF** or **FREESPOOL** are selected.

LINE-IN

Moving the lever directs a pilot signal to the directional control valve, which in turn controls oil flow to the hydraulic winch motor. Pilot pressure is sequenced to release the holding brake as the directional valve begins supplying flow to the motor. Moving the lever toward the operator causes the drum to begin turning and reeling in wire rope.

The lever is a proportional controller: the amount of flow is proportional to the amount of lever movement. Moving the lever a small amount turns the drum slowly; the speed increases as the lever is moved further. Gradually releasing the lever slows the line speed until the drum stops. When the drum stops, the brake is automatically set. Inching control of the line can be achieved by small movements of the lever.

LINE-OUT

LINE-OUT is controlled in the same manner as **LINE-IN**, except the lever is moved away from the operator. **LINE-OUT** speed is also proportional to lever movement. When the lever is returned to the **BRAKE-ON** position, the brake is automatically applied.

SWITCHES (All installations except Y46)

FREESPOOL and **HI-SPEED** are controlled by illuminated switches (see Figure 12) on all installations except for Y46. See page 18 for details of Y46 installation.

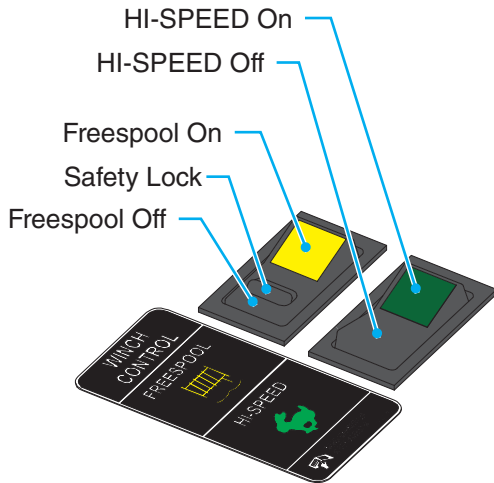

Figure 12 Typical Illuminated Switches Detail

FREESPOOL Operation

WARNING

The winch motor will activate if the lever is moved but the drum will not be in control.

WARNING

Do not use **FREESPOOL** if there is a load on the wire rope. An uncontrolled release of the load will occur. Loss of the load can result in injury and/or equipment damage.

FREESPOOL is controlled by the rocker switch with a yellow indicator. A safety lock prevents the switch from being accidentally turned on. To operate the switch, slide the locking tab first, then push the rocker switch.

FREESPOOL mechanically disengages the winch drum from the drive train, so wire rope can be pulled from the winch by hand. It also releases the brake to allow re-engagement of the gear train when **FREESPOOL** is turned off. When the **FREESPOOL** switch is turned on, the yellow indicator will light.

FREESPOOL must be disengaged by the operator or it will stay on. Turn the switch off to disengage.

HI-SPEED Operation

On two-speed winches, a second rocker switch selects the **HI-SPEED** mode. When activated, a green indicator will be lit. To achieve high speed, the hydraulic winch motor operates at reduced displacement and the same pump flow turns the motor faster, producing higher line speed. **HI-SPEED** approximately doubles the line speed. Note that while operating in **HI-SPEED**, the amount of force the winch can pull is reduced.

The winch speed can be switched from low to high speed or back to low speed while the winch is moving. The operator may notice a momentary increase in motor noise during the transition. This is normal. If line pull exceeds a certain percentage of the rated load, the winch will automatically shift to low speed.

When in **HI-SPEED**, the motor will exhibit an increased level of noise than when used in low speed.

SWITCHES (Y46 Installations)

FREESPOOL, BRAKE-OFF, and HI-SPEED are controlled by three switches mounted on the right armrest. See Figure 13.

WINCH OFF / WINCH ON / FREESPOOL

The top switch is a 3 position, detented switch. When in the **WINCH-OFF** position, no winch functions will operate and the display screen will show the winch as off.

When in the **WINCH-ON** (center) position, the winch is on and may be operated normally.

When in the **FREESPOOL** position, the winch will go into **FREESPOOL** operation. Freespool can only be activated when the machine is at a stop.

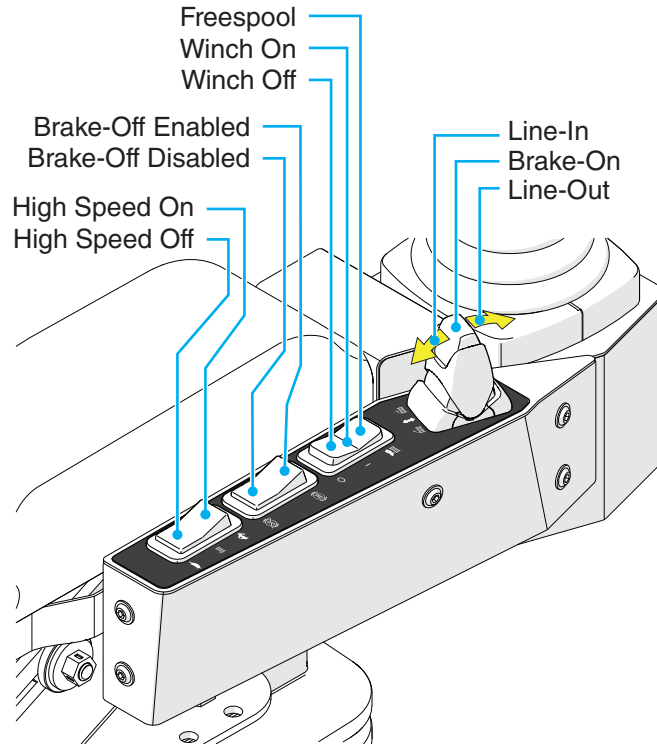

Figure 13 Y46 Controls Detail



WARNING

Do not use FREESPOOL if there is a load on the wire rope. An uncontrolled release of the load will occur. Loss of the load can result in injury and/or equipment damage.

FREESPOOL mechanically disengages the winch drum from the drive train, so wire rope can be pulled from the winch by hand. It also releases the brake to allow re-engagement of the gear train when **FREESPOOL** is turned off.

FREESPOOL must be disengaged by the operator or it will stay on. Turn the switch back to **WINCH-ON** to disengage.

BRAKE-OFF

BRAKE-OFF is controlled by a momentary rocker switch. When the **BRAKE-OFF** switch is depressed, the brake-off clutch is disengaged, allowing the dozer to move away from a towed load.



WARNING

BRAKE-OFF should not be used to lower a suspended load or a load that can slide down a slope.

The **BRAKE-OFF** position is used when there's a load on the winch wire rope. It allows the operator to slowly move the dozer away from the load while spooling wire rope off the drum in a controlled manner.

Hydraulic pressure is applied to release the brake-off clutch. As wire rope is pulled from the winch, the turning drum back-drives the winch gear train to the brake-off clutch. The winch motor and brake remain stationary. Mechanical drag through the gear train and viscous drag in the brake-off clutch keep the wire rope from bird-nesting as it spools off the drum.



WARNING

BRAKE-OFF should not be used if there is a load on the wire rope. An uncontrolled release of the load will occur. Loss of the load can result in injury and/or equipment damage.

HI-SPEED Operation

The rear rocker switch is detented, and selects the **HI-SPEED** mode.

To achieve high speed, the hydraulic winch motor operates at reduced displacement and the same pump flow turns the motor faster, producing higher line speed. **HI-SPEED** approximately doubles the line speed. Note that while operating in **HI-SPEED**, the amount of force the winch can pull is reduced.

The winch speed can be switched from high to low speed while the winch is moving. The operator may notice a momentary increase in motor noise during the transition. This is normal. If line pull exceeds a certain percentage of the rated load, the winch will automatically shift to low speed. It will stay in low speed until the operator fully releases the winch lever and the winch comes to a stop. When the lever is pulled or pushed, it will automatically attempt to operate in **HI-SPEED** again.

When in **HI-SPEED**, the motor will exhibit an increased level of noise than when used in low speed.

FREESPOOL Drag Adjustment

The preload on the bearings of the intermediate shaft controls the resistance to rotation of the drum during the **FREESPOOL** operation. The resistance to rotation is correct when the drum can be rotated by hand, but the drum will not rotate more than one-half revolution freely.

An adjusting screw is located in the center of the bearing retainer for the intermediate shaft; please refer to Figure 14. This screw can be tightened or loosened to adjust the preload on the intermediate shaft. The jam nut will maintain the **FREESPOOL** setting.

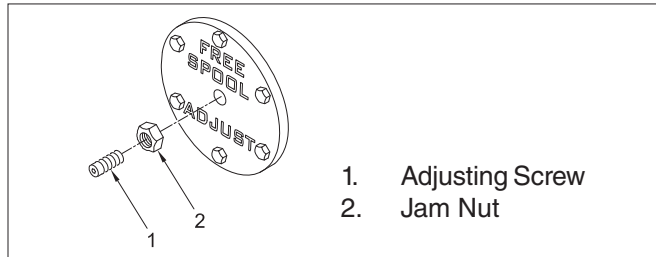

Figure 14 FREESPOOL Adjustments

CAUTION

Setting the preload on the intermediate shaft too tight will cause bearing overload. Setting the preload too loose will allow shaft to not be parallel. Extreme care must be used when adjusting FREESPOOL drag. Determine the correct preload by starting with the preload too loose, and gradually increase the preload until the correct resistance to rotation is achieved (see above). Increase the preload by turning the adjusting screw by a maximum of 1/6 rotation (60 degrees), and striking the housing with a hammer to make sure the bearing is sliding. Check resistance to rotation after each adjustment.

Maintenance

The Maintenance Schedule is a program that includes periodic inspection and lubrication. Use the operating time

on the hour meter of the dozer to find the maintenance time for the winch.

Maintenance Points

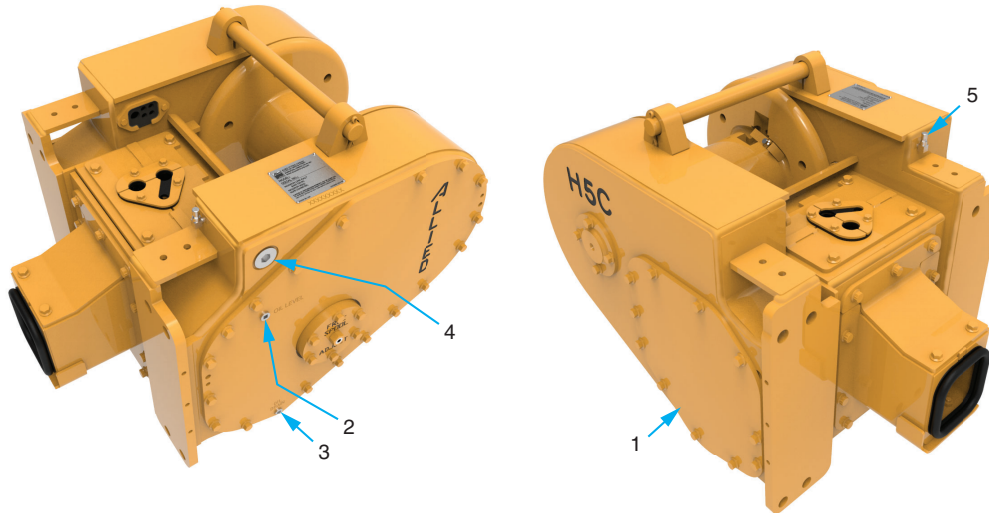

- | | |
|--|------------------|
| 1. Access Cover for Motor and Winch Hydraulics | 4. Oil Fill Plug |
| 2. Plug to Check Oil Level | 5. Breather |
| 3. Plug to Drain Oil | |

Figure 15 H5C Winch Maintenance Points

Maintenance Schedule

INTERVAL	PROCEDURE OR QUANTITY	SPECIFICATION
50 hours or weekly	Check oil level at plug (item 2). Add oil as necessary through fill plug (item 4). (See Figure 15 on page 22.) Do not operate winch when checking the oil level.	See Oil Selection and Oil Capacity for details.
	Clean the breather (item 5).	Remove debris around breather. Clean the breather with solvent if necessary.
	Lubricate the rollers on the integral arch or the fairlead assembly, if the winch is equipped with either of these options.	Use multi-purpose grease with 2-4% molybdenum disulfide.
2000 hours or every 12 months	Change the gear oil. Drain oil from plug (item 3). Add 16 liters (17 quarts) through fill plug (item 4). Check the oil level at oil level check plug (item 2).	See Oil Selection and Oil Capacity for details.

Figure 16 Maintenance Schedule

Troubleshooting Chart

PROBLEM	POSSIBLE CAUSE	CORRECTION
Operation is rough or not regular.	Hydraulic oil is too cold.	Allow dozer hydraulics to warm up.
	Low oil level.	Add oil.
Hydraulic oil becomes too hot.	Winch is operated for long periods.	Allow unit to rest. Ensure cooler is installed.
	Low oil level.	Add oil.
Brake begins to release before the motor moves the drum.	Brake is worn or needs replacement.	See the Service Manual for additional information.
	Brake valve is out of adjustment.	
Winch brake does not apply or release correctly.	Brake is worn.	See the Service Manual for additional information.
	Brake valve is out of adjustment or low pressure.	
FREESPOOL does not operate correctly.	Low pressure.	See the Service Manual for additional information.
	Load on wire rope.	
Oil is coming out of the breather.	Leak in FREESPOOL hose or shift fork.	See the Service Manual for additional information.

Figure 17 Troubleshooting Analysis Chart

Operating Techniques

Dozer or Skidder Operation

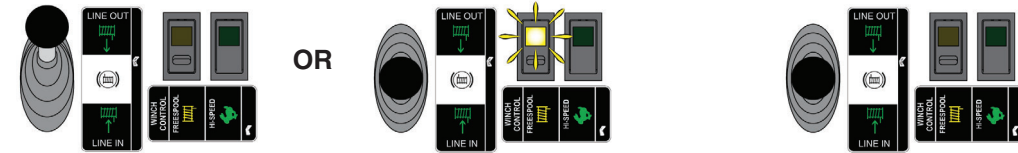

C805 controls shown.
Your controls may vary.

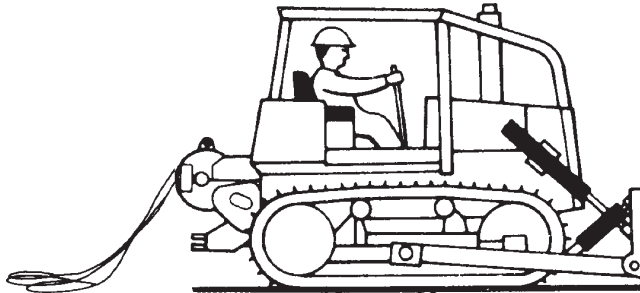

Step 1. The dozer or skidder is moved to an area where a load will be connected. The operator moves the control lever to the **LINE-OUT** position or activates the **FREESPOOL** switch so that the wire rope can be pulled from the winch drum.

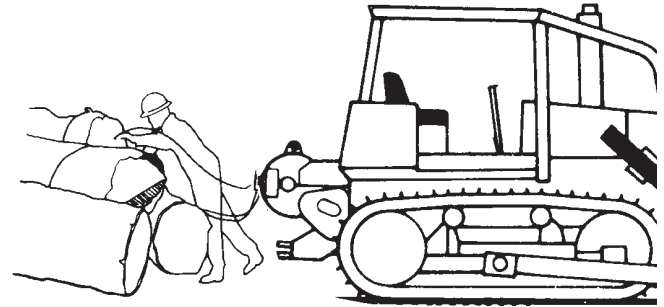

Step 2. A load (logs) is connected to the wire rope. If **FREESPOOL** was used, the operator must deactivate the **FREESPOOL** switch.

C805 controls shown.
Your controls may vary.

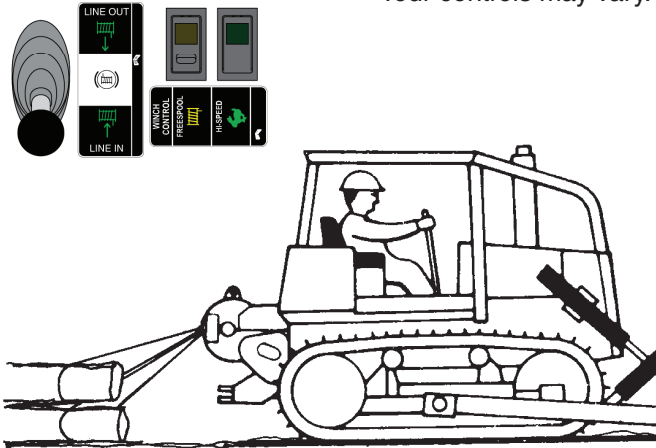

Step 3. The operator can move the control lever to the **LINE-IN** position. If the load is less than approximately 50% of the maximum line pull, the operator can begin traveling with the vehicle at the same time. The winch will wind the load toward the vehicle as it travels. If the load is nearly the capacity of the line pull, the operator must move the load close to the vehicle before beginning to travel.

Y46 controls shown.
Your controls may vary.

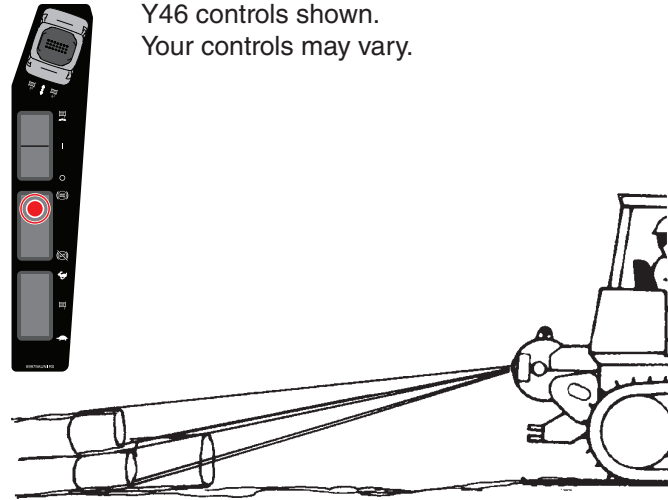

Step 4. If the dozer or skidder must travel through an area with bad traction conditions and the winch is equipped with the **BRAKE-OFF** option, the operator can press and hold the **BRAKE-OFF** switch. This will permit the vehicle to move slowly through the bad traction area without pulling the load at the same time.

Operating Techniques



Y46 controls shown.
Your controls may vary.

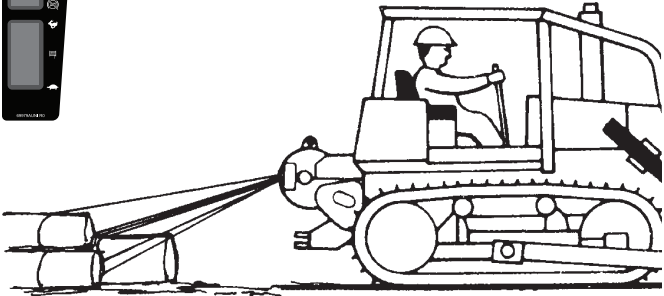

Step 5. When the vehicle is on firm ground, the operator can release the **BRAKE-OFF** switch and move the control lever to **LINE-IN** to pull the load toward the vehicle.

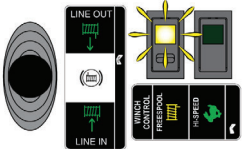

C805 controls shown.
Your controls may vary.

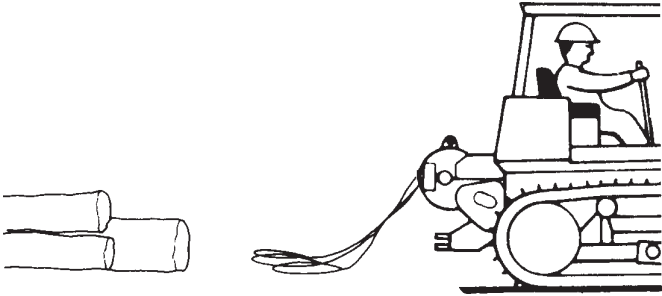

Step 6. When the operator wants to disconnect from the load, the vehicle is stopped and the **FREE-SPOOL** switch is activated to loosen the wire rope. The wire rope is then disconnected from the load.

How to Move a Disabled Vehicle

A. A dozer or skidder often travels in areas where traction conditions are bad. A vehicle equipped with a winch can be used to remove itself from mud or other areas where it cannot move using only the drive wheels or tracks. See Figure 18. Use the following procedure:

1. Fasten the winch wire rope to a structure, tow bar of another vehicle, or a tree that has enough strength for the line pull. The wire rope must be in a direction that is approximately parallel to the direction of travel of the vehicle.
2. Use the throttle to set the engine speed at a power level to operate both the winch and the tracks or drive wheels. (Operator experience is required, because the winch can use most of the engine power in some vehicles.)
3. Put the control lever in the **LINE-IN** position to tighten the winch wire rope. When the winch wire rope is tight, put the vehicle transmission in **REVERSE** and engage the tracks or drive wheels. Use the power from the engine to the winch and tracks together to remove the vehicle from the bad area.

4. If the vehicle travels faster than the winch winds the wire rope, disengage the transmission until the winch wire rope is tightened again. Do not drive over the wire rope.

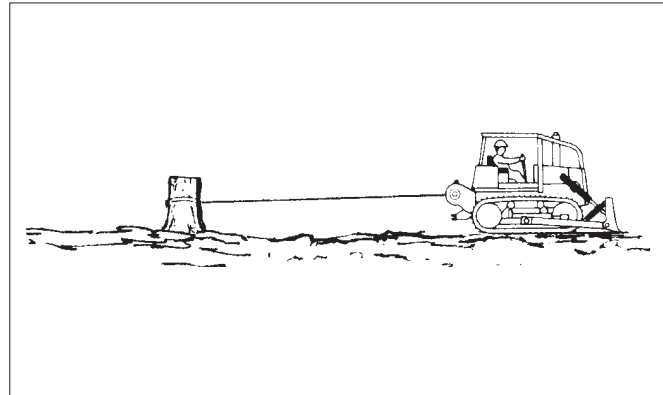

Figure 18 Moving a Disabled Vehicle (Step A)

Operating Techniques

B. A dozer or skidder equipped with a winch can be used to pull another vehicle from mud or other areas where it cannot move using only the drive wheels or tracks. See Figure 19. Use the following procedure:

WARNING

Bad traction can cause the disabled vehicle or the dozer to slide. A slope can require additional distance to stop the vehicles.

Ensure the wire rope and tow chain have the capacity to do the job. If the disabled vehicle does not have a tow pin or other equipment for towing, carefully fasten the tow chain around the axle of the disabled vehicle. Make sure the tow chain is fastened so that the chain will not injure people or damage the vehicle.

An operator must be on the disabled vehicle to operate the steering and brakes when it is towed.

1. Fasten the winch wire rope to the tow bar of the other vehicle. The wire rope must be in a direction that is approximately parallel to the direction of travel of the vehicle. Apply the brakes on the dozer or skidder. Use the throttle to set the engine speed at a power level to operate the winch. (Operator experience is required, because the winch can use most of the engine power in some vehicles.)
2. Put the control lever in the **LINE-IN** position to tighten the winch wire rope. When the winch wire rope is

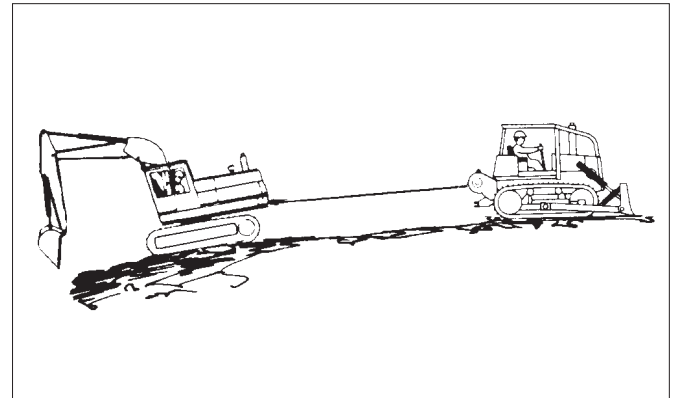

Figure 19 Moving a Disabled Vehicle (Step B)

tight, use the power from the engine to the winch to pull the vehicle from the bad area. If the disabled vehicle moves under its own power, keep the towing wire rope tight so that the wire rope does not pass under the drive wheels or tracks of the vehicle being towed.

Working on a Steep Slope



WARNING

The winch and the dozer must be in good condition for the following procedures. Make sure all required maintenance has been done on the dozer and winch. Use only a wire rope that is in good condition. Make sure the wire rope and winch have enough capacity for the load. Make sure the anchor for the wire rope has enough capacity for the load. A failure of the dozer, winch, or wire rope while working on a steep slope can cause death or injury and loss of equipment.

Dozer is Down the Slope (See Figure 20).

Sometimes a dozer must work on a steep slope and can use a winch to give assistance when moving on the slope.

Fasten the winch wire rope to the drawbar of another dozer, a structure or a tree that has enough strength to hold the dozer on the slope.

A. Moving down the slope:

1. Set the throttle on the dozer for the required engine speed.
2. Put the dozer in **FORWARD**. At the same time, move the winch control lever to a position between **BRAKE-ON** and **LINE-OUT** (inching) to control the speed of the dozer down the slope.

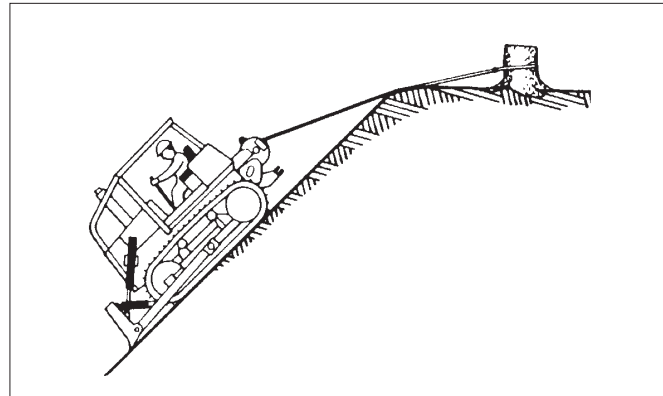

Figure 20 Working on a Steep Slope

Operating Techniques

B. Moving up the slope:

1. Set the throttle on the dozer for the required engine speed.
2. Put the control lever in **LINE-IN** position to tighten the winch wire rope. When the winch wire rope is tight, put the dozer transmission in the **FIRST** speed range and **REVERSE** and engage the tracks or drive wheels. At the same time, move the control lever on the winch to **LINE-IN**.
3. Use the steering on the dozer to keep the travel of the dozer in line with the winch wire rope.
4. Engage **LINE-IN** as necessary. Do not permit the winch wire rope to loosen and pass under the drive wheels or tracks of the dozer.

Other Equipment is Down the Slope (See Figure 21).

In this operation, the dozer and winch are on stable ground and other equipment is working on a steep slope. The winch is used to give additional control to the equipment working on the steep slope. A winch with a fairlead option is recommended for this operation if alignment of the other equipment with the winch and dozer is a problem.

Make sure the dozer and winch are on stable ground and will not slide when the load is applied. Align the dozer and winch with the load. Apply the parking brake on the dozer.

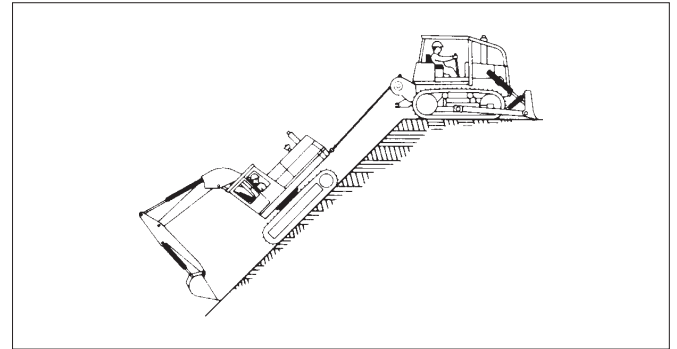

Figure 21 Other Equipment on a Steep Slope



A. Lowering the equipment on the slope:

1. Set the throttle on the dozer for the required engine speed. Operator experience is required for this operation so that the load is carefully controlled.
2. Keep the winch wire rope tightened between the dozer and the equipment being lowered down the slope. Use the control lever in the **LINE-OUT** position to control the lowering of the equipment down the slope.
3. Move the control lever between **LINE-OUT** and **BRAKE-ON** if inching is required.

B. Raising the equipment on the slope:

1. Set the throttle on the dozer for the required engine speed. Operator experience is required for this operation so that the load is carefully controlled.
2. Keep the winch wire rope tightened between the dozer and the equipment being raised up the slope. Use the control lever in the **LINE-IN** position to control the raising of the equipment up the slope.
3. Move the control lever between **LINE-IN** and **BRAKE-ON** if inching is required.
4. Keep the equipment being raised in alignment with the winch and dozer. Do not permit the winch wire rope to loosen and pass under the drive wheels or tracks of the dozer.

Operational Differences, Optional Equipment

Operational Differences, Optional Equipment

Integral Arch

When using an integral arch, the wire rope is routed over a raised horizontal roller and through a set of smaller vertical side rollers and an upper horizontal roller. This enables the winch to pull upwards versus horizontally on loads. In this way, the load can be lifted slightly to reduce drag due to ground contact. The side and top rollers act as fairleads to protect the wire rope from damage and from damaging the frame.

Because the line of action of the wire rope is higher than normal, the tipping moment applied to the dozer is increased, and the dozer will tip backwards at significantly lower line pulls. The operator must exercise care to not pull more than the dozer can handle stably, especially on side slopes.

Line pulls through the arch also exert higher loads on the fasteners holding the winch to the dozer. For this reason, the wire rope diameter is limited. Refer to tag, manual, or consult the factory.

Fairlead

A fairlead consists of a set of top and bottom horizontal rollers and side rollers that the wire rope is fed through. With this attachment, if the direction of line pull is not directly behind the fairlead rollers instead of across the frame, thus protecting both the frame and the wire rope from excessive wear.

Stability of the dozer is affected somewhat by the fact that the fairlead rollers are more rearward than the drum, thus putting slightly more moment on the dozer during side pulls. The operator must take care to assure stability on slopes.



Drawbar

Do not use the drawbar as an anchor point for a multi-point (over puller) line from the winch. Loads applied to the drawbar are transmitted to the bolts holding the winch to the dozer. Standard integral drawbars are designed to handle pulls of 66% of winch rated capacity; bolt on drawbars are 60%. Optional heavy duty and extended drawbars are available which increase the capacity of the drawbar and/or move the pin farther back so it is not under the winch drum.

Optional Gear Ratios

Lower speed ratios allow better operator control of line speed. They may also allow the winch to pull in excess of wire rope or winch rated capacity. They do not increase the durability or damaging load limit of the winch. Line pulls in excess of rated capacity will dramatically reduce the life of winch components.

Notes



Notes

NO MATTER HOW YOU SAY IT ...

La Prudence Paye
La Seguridad Paga
Betriebssicherheit Macht Sich Bezahlt
Passaa Olla Huolellinen
Veiligheid Voor Alles
Säkerhet Först
Essere Sicuro Paga
Segurança Paga
Sikkerhet Først
Pinter Be Awas

सावधान और रिहा रहौ ।

في التآني السرمة

安全第一



SAFETY PAYS!

SAFETY PAYS!



® To find a dealer in your area,
Call: 503.625.2560,
Fax: 503.625.7269, or
Email: marketing@alliedsystems.com, or
Visit our website: www.alliedsystems.com

Allied Systems
C O M P A N Y

599070W

08/19/2024

Printed in U.S.A.