

CARCO®

WINCH PARTS MANUAL

MODEL H60VS

NOTE: This manual covers all common winch parts only. For all other parts, refer to the installation and parts manual for your specific tractor. Because this manual covers several winch configurations, not all parts shown will apply to your winch. Care should be taken to properly identify parts before replacements are ordered. Always include the winch model and serial numbers when requesting information or ordering parts.

TABLE OF CONTENTS

Case and Covers.....	1-2
Hydraulic Control Group.....	3-4
Valve Group	5-6
Valve Assembly.....	7-8
Cartridge Group.....	9
Brake Assembly	10
Clutch Assembly.....	11
Carrier Clutch Assembly.....	12
Sprag Clutch Assembly.....	13
Cable Drum Group	15-16
Idler Shaft Group w/Freespool	17
Freespool Cylinder Assembly.....	18
Fourth Shaft Group.....	19
Fairlead Assembly.....	20

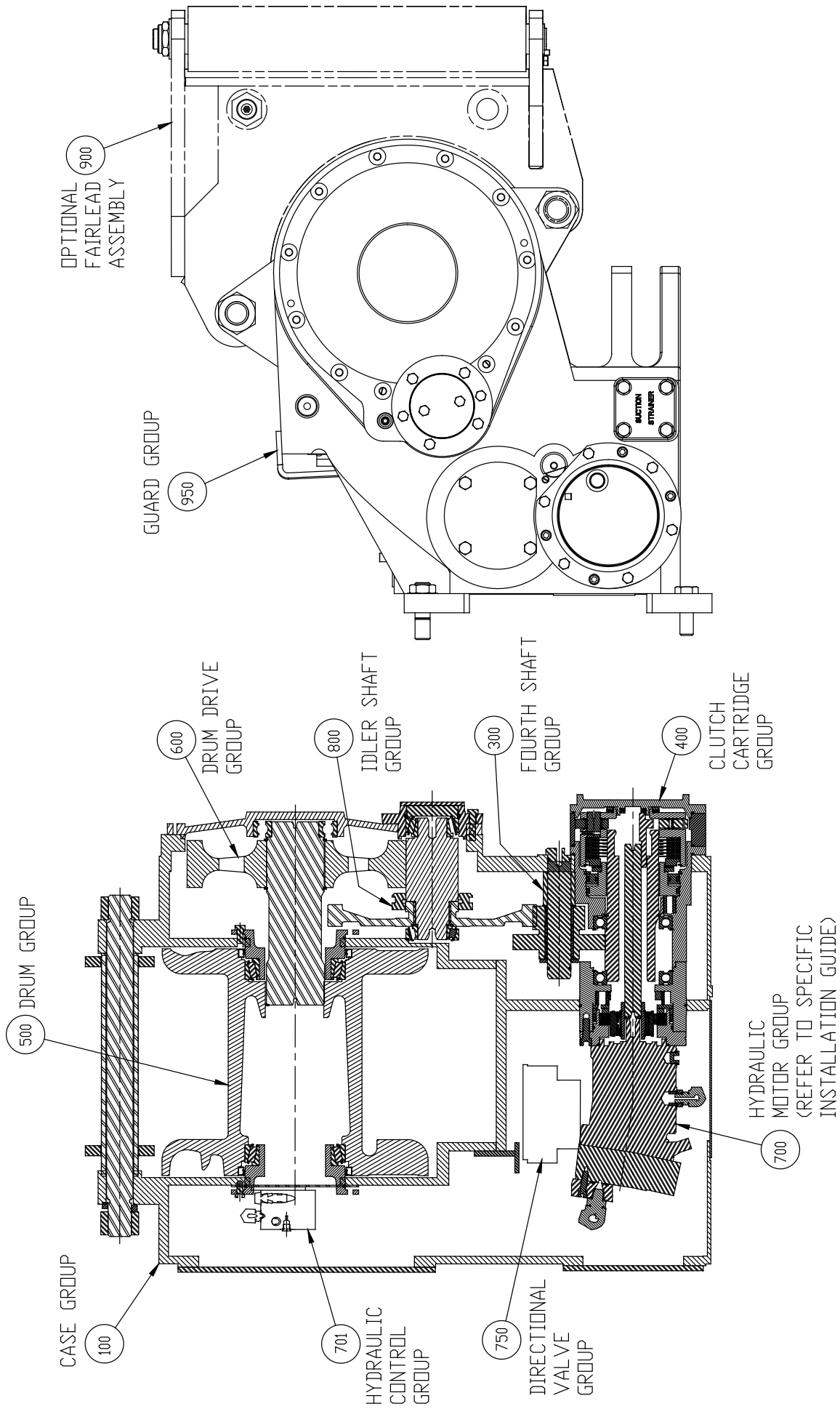

**CASE AND COVERS GROUP
H60VS**

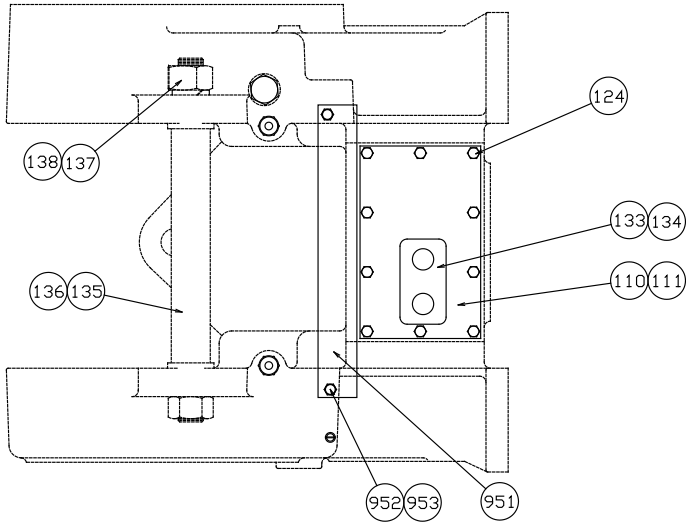

NOTES:

1. APPLY 'LOCTITE 242' TO CLEAN, DRY THREADS AND TORQUE FASTENERS TO 75-83 FT-LBS.
2. APPLY 'RTV 732' SILASTIC SEALANT

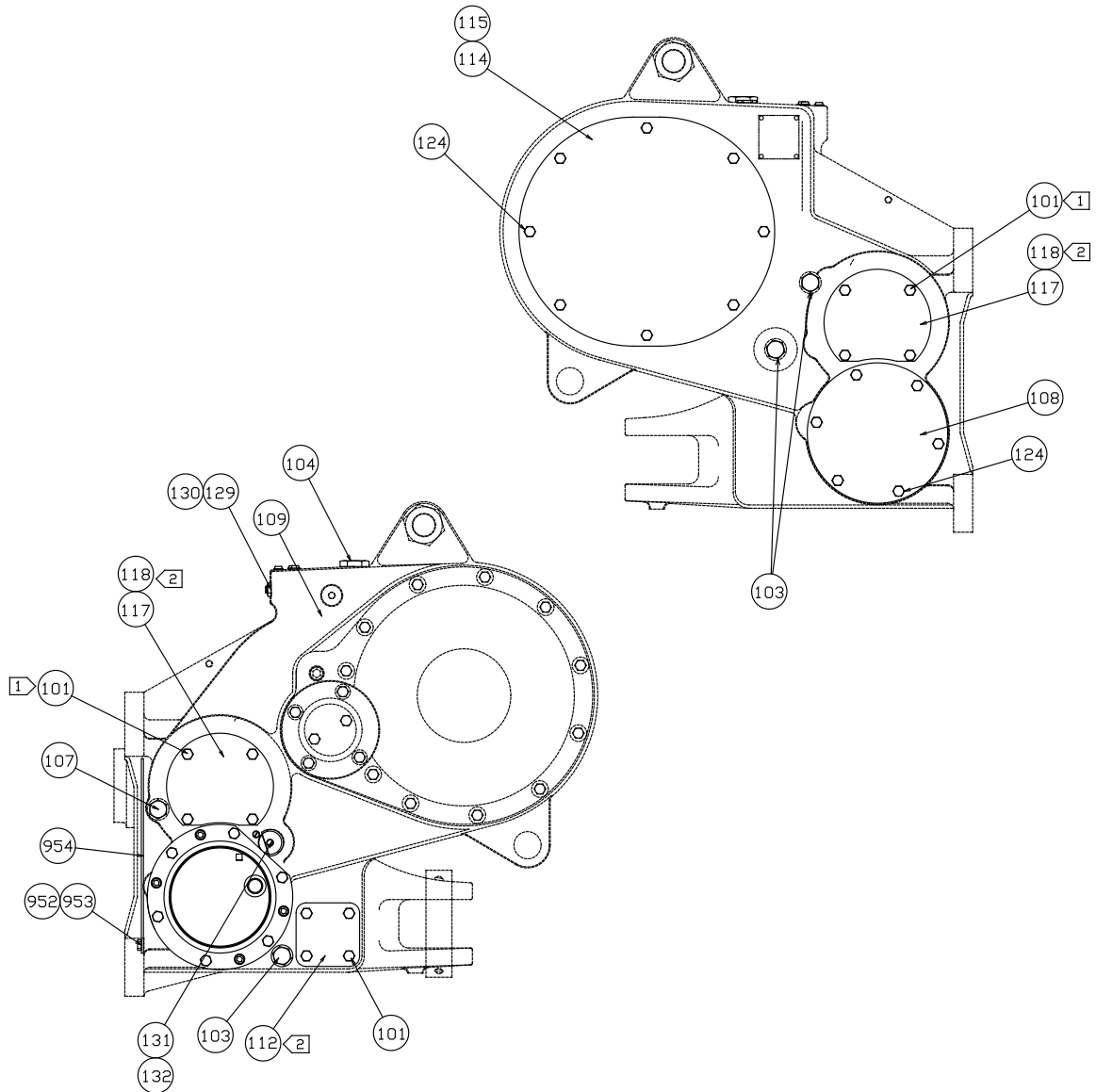

**CASE AND COVERS GROUP
H60VS**

ITEM NO.	PART NO.	DESCRIPTION	QTY.
101	104320	CAPSCREW, HEX HD (1/2-13 X 1, G5 Z)	12
103	70118	PLUG	3
	31607	O-RING	3
104	29825	PLUG	1
	31608	O-RING	1
107	70193	SIGHT GAUGE	1
108	105469	COVER	1
109	105235	WINCH CASE	1
110	105467	COVER, TOP	1
111	27806	TOP COVER GASKET	1
112	26174	COVER	1
114	69951	COVER, SIDE ACCESS	1
115	69950	GASKET	1
117	27807	COVER, ACCESS	2
118	27808	GASKET	2
124	27745	CAPSCREW, HEX HD (1/2-13 X 1, G5 SS)	24
129	26868	REDUCER	1
130	10074	VENT	1
131	103250	CAPSCREW, HEX HD (1/2-13 X 3/4, G8 Z)	1
132	100859	WASHER, HARD (1/2, Z)	1
133	106405	TUBE COVER	1
134	106443	ADJUSTING NUT	1
135	27804	TUBE	1
136	28772	TIE BOLT	1
137	27666	WASHER, LOCK	1
138	27655	NUT, HEX HD	2
951	105468	GUARD	1
952	104174	CAPSCREW, HEX HD (1/2-13 X 1 1/4, G8 Z)	10
953	102987	WASHER, HARD (1 1/4)	10
954	105471	COVER	1

HYDRAULIC CONTROL GROUP H60VS

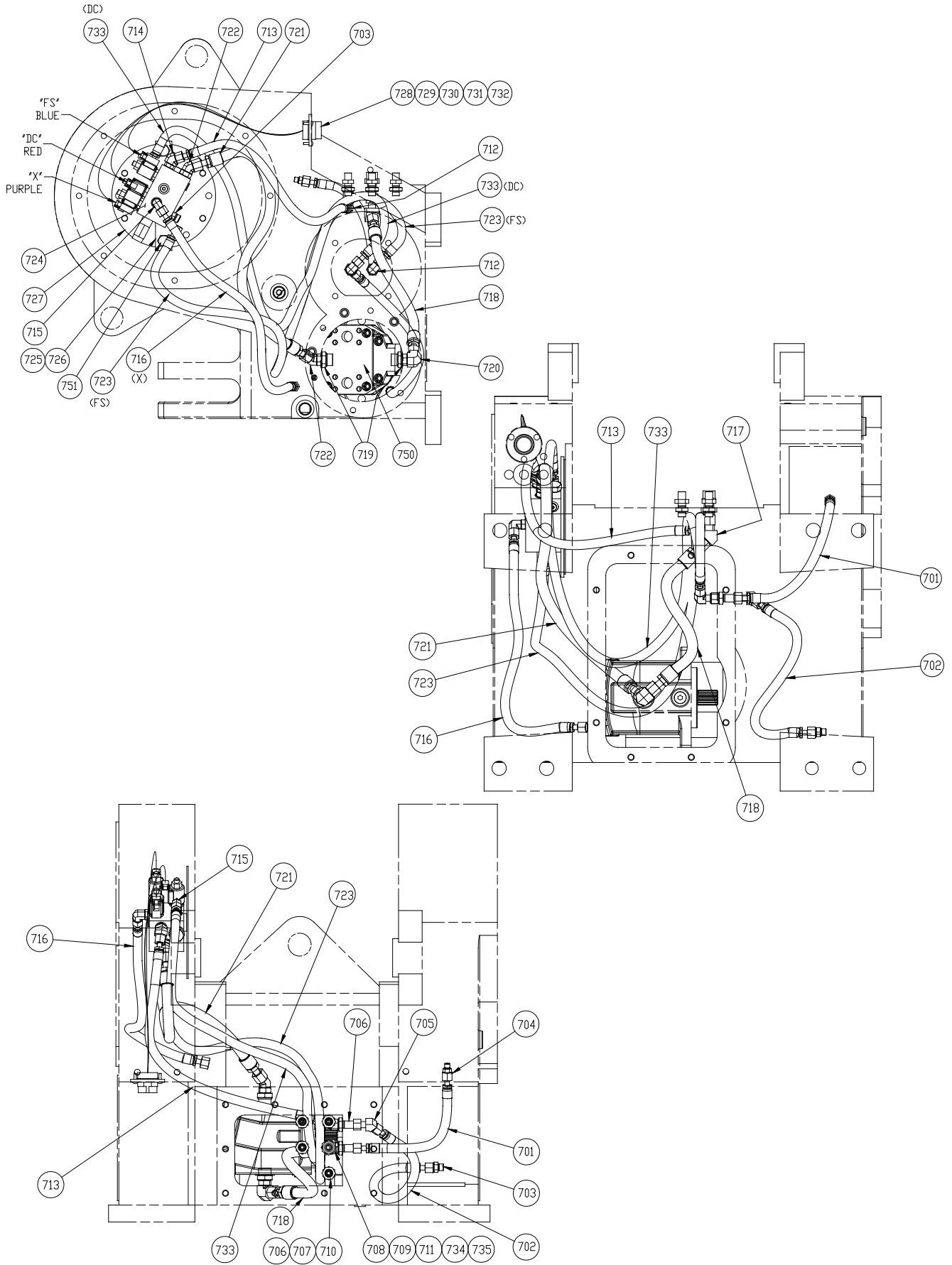

**HYDRAULIC CONTROL GROUP
H60VS**

ITEM NO.	PART NO.	DESCRIPTION	QTY.
701	101435	HOSE ASSY -6 X 16 in (406 mm)	1
702	106372	HOSE ASSY -6 X 21 in (533 mm)	1
703	101222	ADAPTER	2
704	100946	ADAPTER	1
705	101281	ELBOW, 45°	1
706	103224	BULKHEAD UNION	6
707	105459	BULKHEAD NUT	4
708	105961	BULKHEAD UNION	1
709	106386	BULKHEAD NUT	1
710	101581	CAP	4
711	105963	CAP	1
712	100945	ELBOW, 90° SWIVEL	3
713	101260	HOSE ASSY -6 X 27 in (686 mm)	1
714	101286	ELBOW, 45°	1
715	40107	ELBOW, 90°	2
716	101259	HOSE ASSY -6 X 23 in (584 mm)	1
717	105964	ELBOW, 45°	1
718	105965	HOSE ASSEMBLY -8 ORFS X 15 in (381 mm)	1
719	101218	REDUCER	2
720	101282	ELBOW, 90°	1
721	101830	HOSE ASSY -8 X 29 in (737 mm)	1
722	101438	ELBOW, 45°	2
723	106221	HOSE ASSY -6 ORFS X 45 in (1143 mm)	1
724	105002	VALVE (REFER TO PAGE 8)	1
725	105466	VALVE MOUNTING PLATE	1
726	21043	CAPSCREW, FLAT HD HEX SOCKET (⁵ / ₁₆ -18 X ³ / ₄ , G8)	2
727	105523	COVER	1
728	105971	WIRE HARNESS	1
729	13838	O-RING	1
730	100784	FLANGE	1
731	100794	CAPSCREW, BUTTON HD (#10-24 X ⁵ / ₈ , SS)	3
733	106222	HOSE ASSY -6 ORFS X 55 in (1397 mm)	1
734	101943	O-RING	1
735	24400	O-RING	1
750	63689	DIRECTIONAL VALVE GROUP (REFER TO PAGE 6)	1
751	100783	CAPSCREW, HEX HD (¹ / ₂ - 13 X 1- ¹ / ₄ G5, SS)	2

VALVE GROUP H60VS

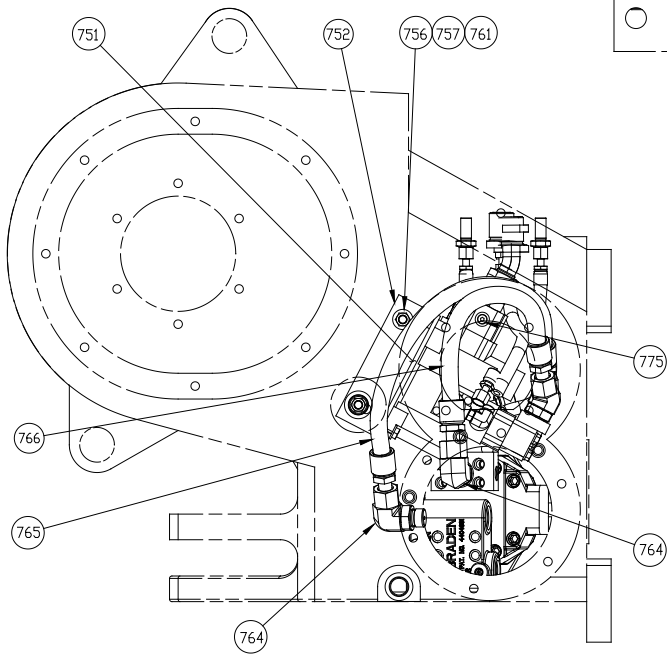
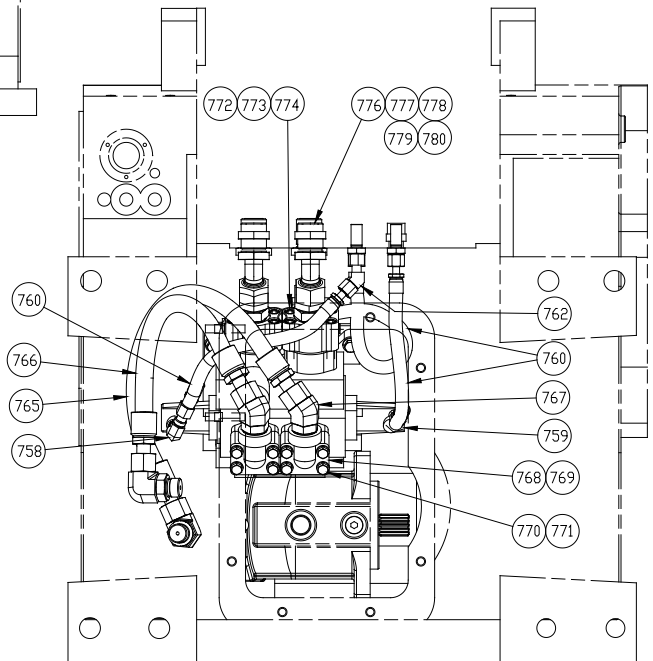
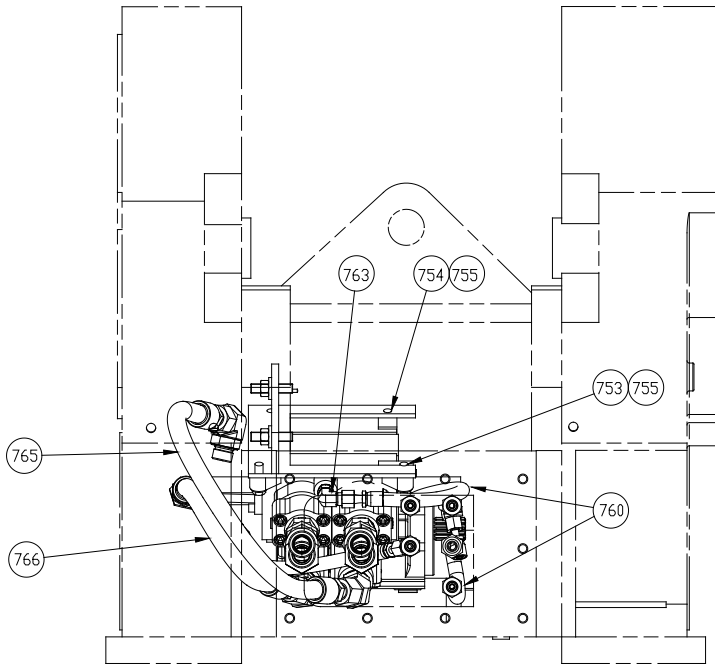

**VALVE GROUP
H60VS**

ITEM NO.	PART NO.	DESCRIPTION	QTY.
--	63689	DIRECTIONAL VALVE GROUP (COMPLETE)	1
751	105242	VALVE	1
	63859	FACE SEAL KIT (CONTROL VALVE)	1
	63860	SECTION SEAL KIT (CONTROL VALVE)	1
752	105460	BRACKET	1
753	21253	CAPSCREW, HEX HD ($\frac{7}{16}$ -14 X 1- $\frac{1}{2}$, G8, Z)	2
754	21964	CAPSCREW, HEX HD ($\frac{7}{16}$ -14 X 1, G8, Z)	2
755	101432	WASHER, HARD ($\frac{7}{16}$)	4
756	27081	STUD	2
757	102987	WASHER, HARD ($\frac{1}{2}$)	2
758	100947	ELBOW, 90°	1
759	101720	ELBOW, 45°	1
760	101435	HOSE ASSY -6 X 16 in (406 mm)	3
761	101439	NUT, HEX ($\frac{1}{2}$ -13, G8, Z)	2
762	101281	ELBOW, 45°	1
763	40107	ELBOW, 90°	1
764	102608	ELBOW, 90°	2
765	105966	HOSE ASSY -12 ORFS X 23 in (584 mm)	1
766	106367	HOSE ASSY -12 ORFS X 19 in (483 mm)	1
767	106371	ELBOW, 45°	2
768	25366	O-RING	2
769	105968	MANIFOLD	2
770	104134	CAPSCREW, HEX HD ($\frac{3}{8}$ -16 X 2- $\frac{1}{4}$, G8, Z)	8
771	101440	WASHER, HARD ($\frac{3}{8}$)	8
772	27434	MANIFOLD	2
773	21150	O-RING	2
774	21144	CAPSCREW, HEX SOCKET HD ($\frac{7}{16}$ -14 X 2, G8)	8
775	69325	PLUG	2
776	104660	ADAPTER	2
777	105969	TUBE ASSEMBLY	2
778	105970	NUT, BULKHEAD	2
779	105524	CAP	2
780	106369	O-RING	2

**VALVE ASSEMBLY
H60VS**

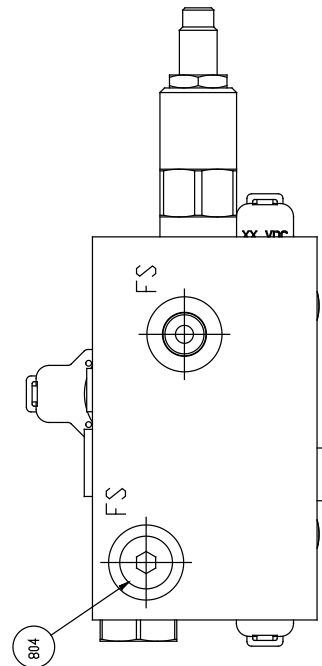
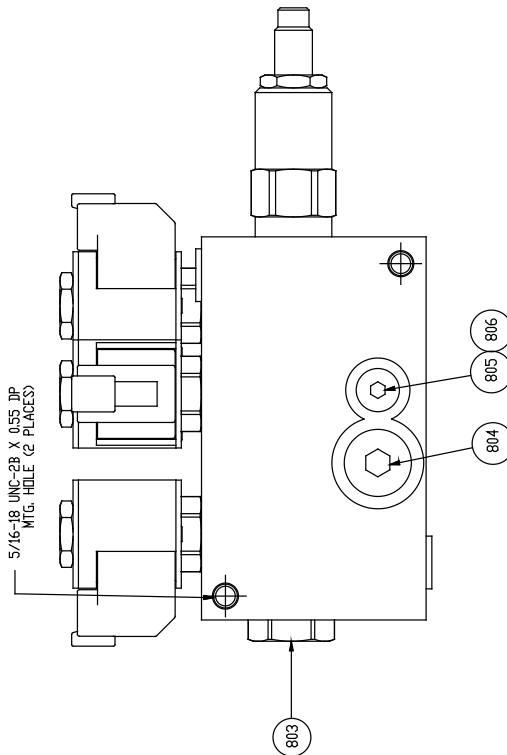
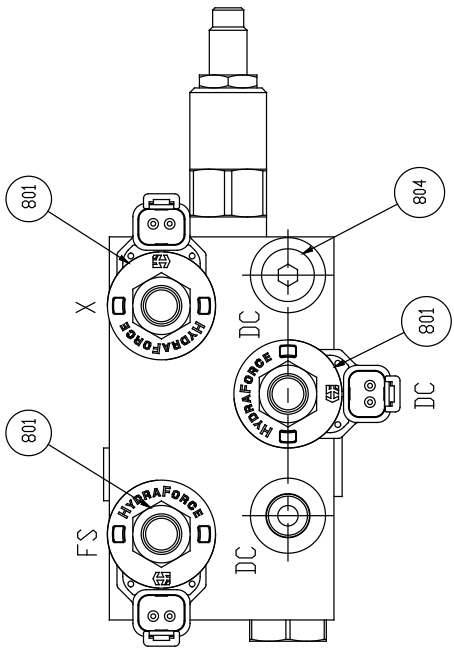
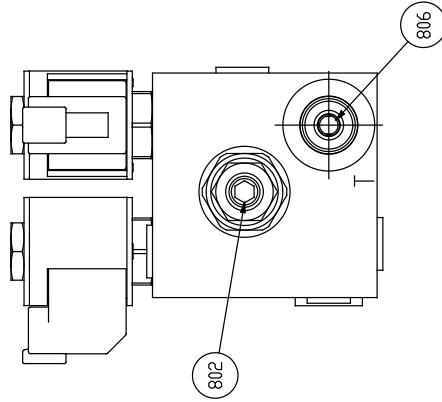
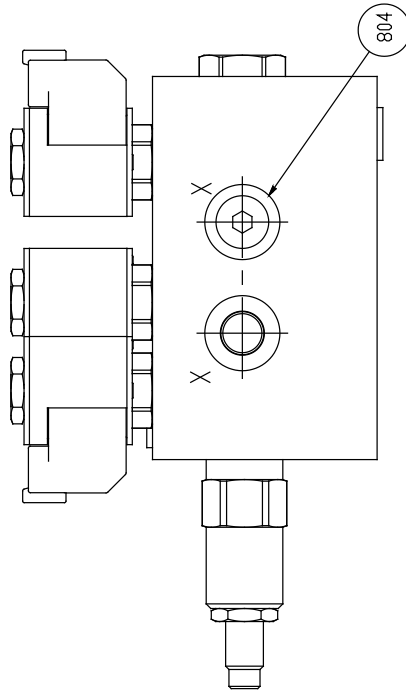
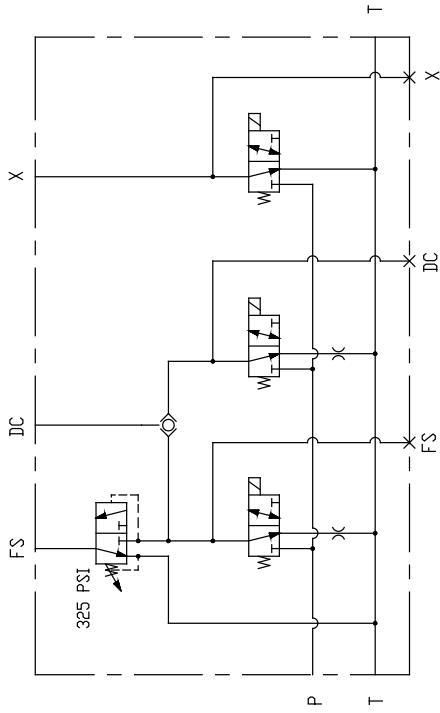

**VALVE ASSEMBLY
H60VS**

ITEM NO.	PART NO.	DESCRIPTION	QTY.
--	105002	VALVE ASSEMBLY (COMPLETE)	1
801	106518	SOLENOID VALVE CARTRIDGE	3
	29821	SEAL KIT (FOR SOLENOID VALVE)	3
	106378	COIL, 24 VDC (FOR SOLENOID VALVE)	3
802	106515	SEQUENCE VALVE CARTRIDGE	1
	29821	SEAL KIT (FOR SEQUENCE VALVE)	1
803	106516	SHUTTLE VALVE CARTRIDGE	1
	63856	SEAL KIT (FOR SHUTTLE VALVE)	1
804	25665	PLUG, -6 ORB	4
805	69325	PLUG, -4 ORB	1
806	106517	ORIFICE PLUG	2

**CARTRIDGE GROUP
H60VS**

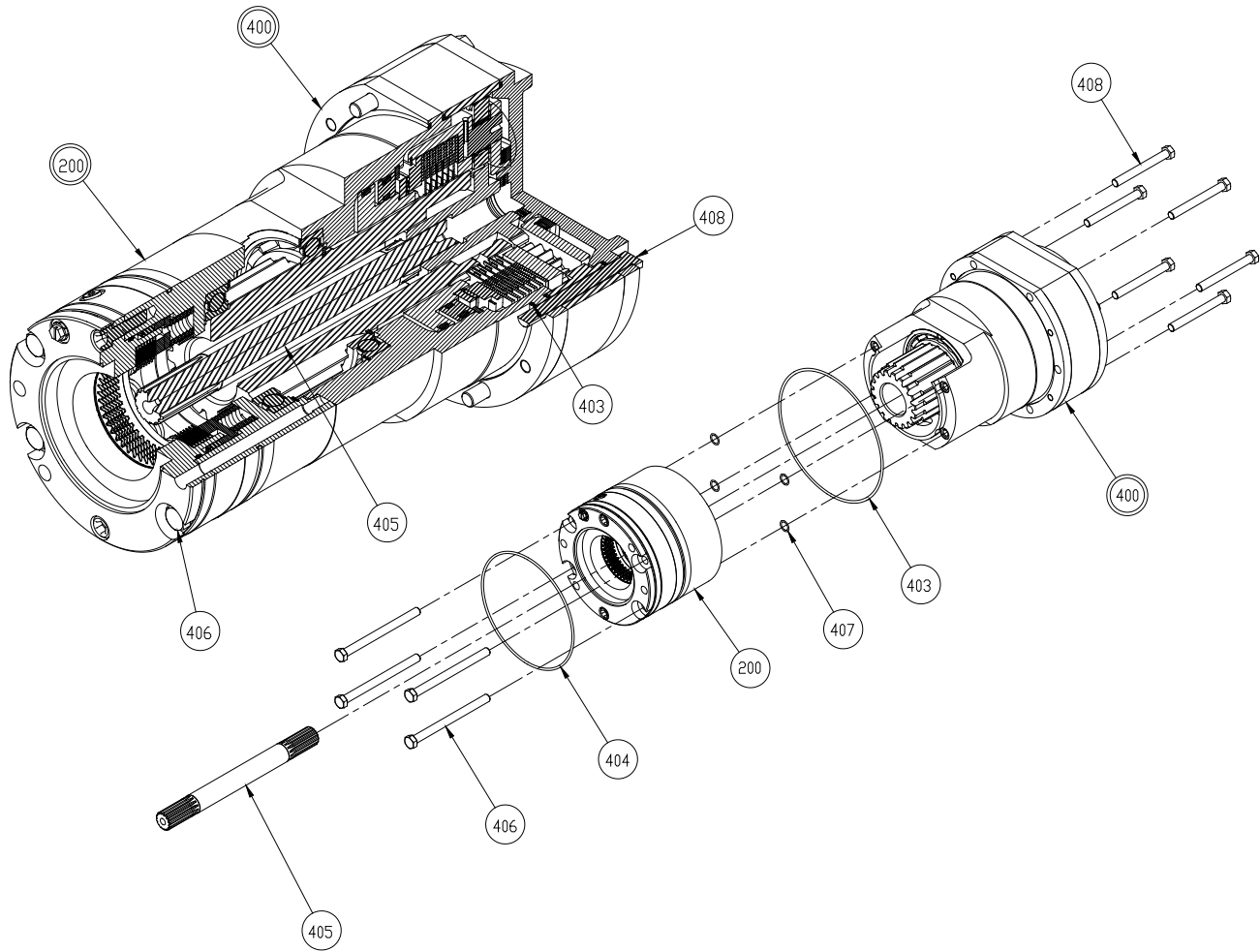

ITEM NO.	PART NO.	DESCRIPTION	QTY.
200	83324	BRAKE ASSY (REFER TO PAGE 10)	1
400	83325	CLUTCH ASSY (REFER TO PAGE 11)	1
403	25108	O-RING	1
404	22358	O-RING	1
405	105237	INPUT SHAFT	1
406	105455	CAPSCREW, HEX HD (1/2-13 X 6 1/2, GD8, Z)	4
407	101943	O-RING	4
408	23560	CAPSCREW, HEX HD (1/2-13 X 4 1/2, GD8, Z)	6

BRAKE ASSEMBLY H60VS

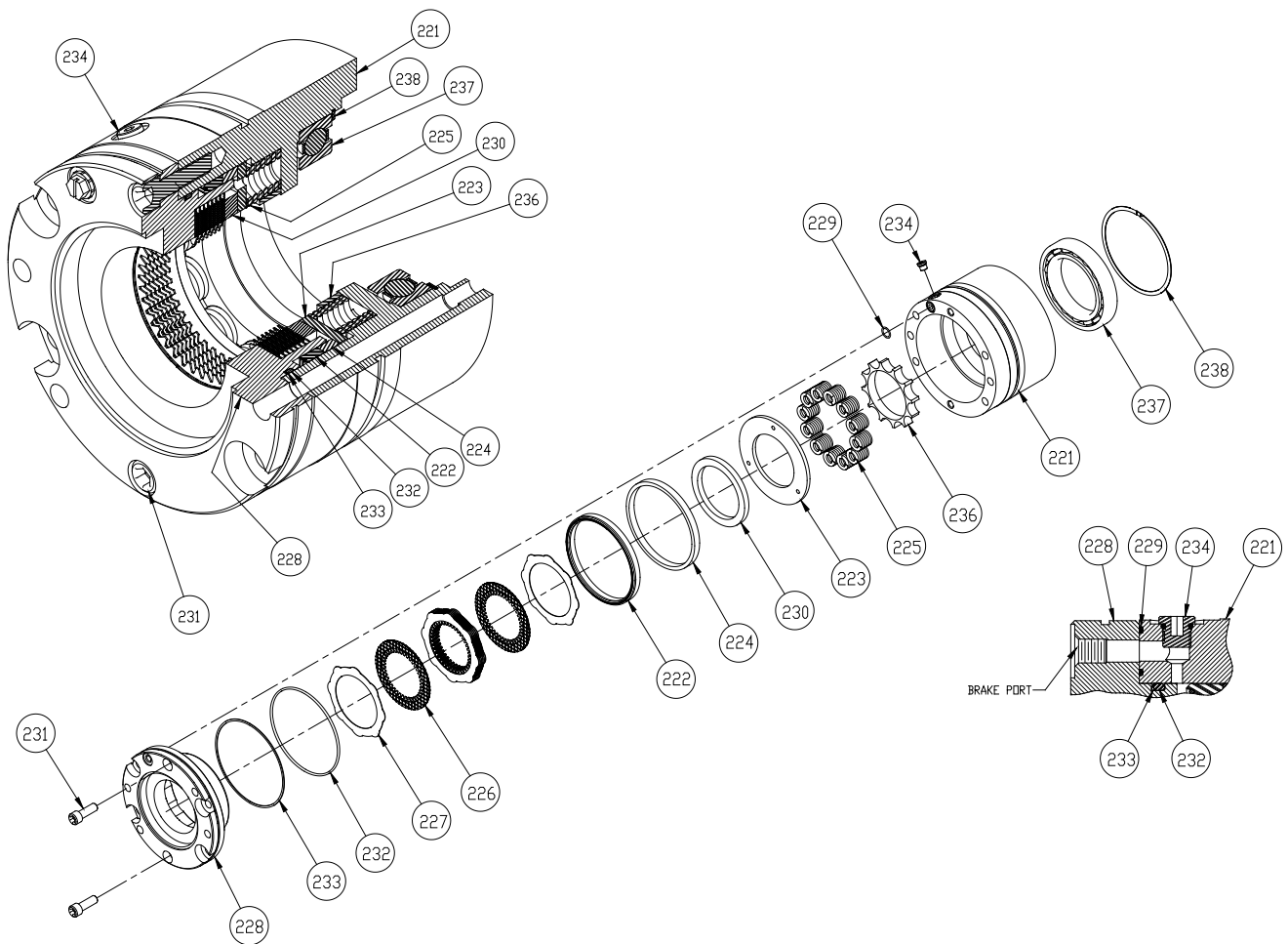

Notice Different Quantities for Standard and Closed Loop

ITEM NO.	PART NO.	DESCRIPTION	QTY.	
			STD	CLOSED LOOP
--	83324	BRAKE ASSEMBLY (COMPLETE)	1	-
	84026	BRAKE ASSEMBLY (COMPLETE)	-	1
221	105240	BRAKE CYLINDER	1	-
	109026	BRAKE CYLINDER	-	1
222	25642	SEAL	1	-
	1109027	SEAL	-	1
223	25635	PRESSURE PLATE	1	-
	109028	PRESSURE PLATE	-	1
224	25636	PISTON BACKUP RING	1	-
225	25644	DIE SPRING	12	12
226	21036	FRICION DISC	7	9
227	100027	BRAKE DISC	8	10
228	105142	MOTOR SUPPORT	1	-
	109030	MOTOR SUPPORT	-	1
229	22452	O-RING	1	1
230	25637	SPACER	1	1
231	21908	CAPSCREW, SOCKET HD (½-13 X 1½, G8, Z)	2	2
232	24981	O-RING	1	-
	109035	O-RING	-	1
233	25643	BACK-UP RING	1	-
	109036	BACK-UP RING	-	1
234	69325	PLUG	1	1
236	100200	SPRING SPACER	1	1
237	105637	BALL BEARING	1	1
238	PA7M1250	RETAINING RING	1	1

CLUTCH ASSEMBLY H60VS

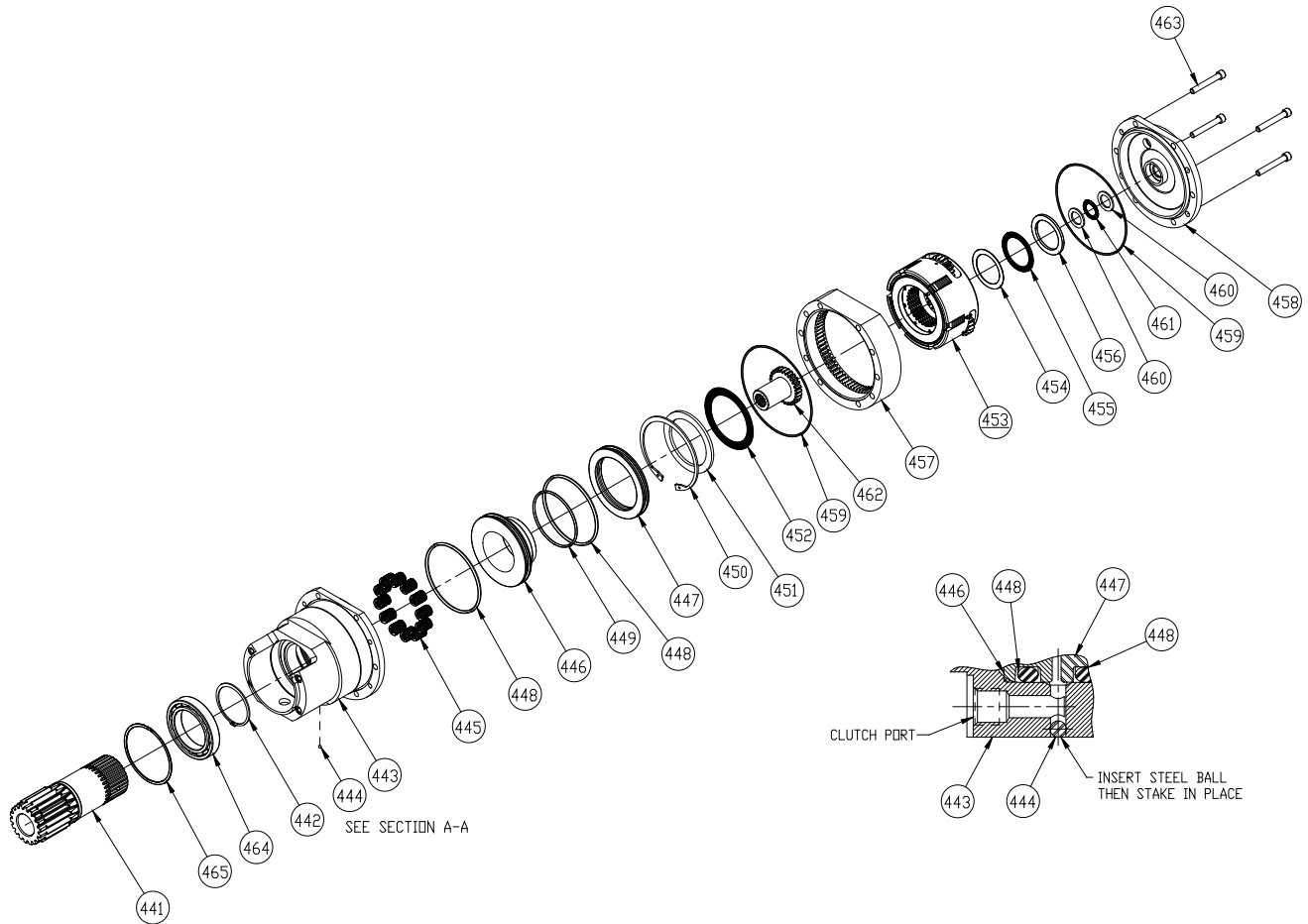

ITEM NO.	PART NO.	DESCRIPTION	QTY.
441	105236	PINION GEAR	1
442	70158	RETAINING RING	1
443	105238	BRAKE CYLINDER	1
444	70126	STEEL BALL	1
445	103013	SPRING	12
446	105147	PISTON	1
447	105146	SEAL RING	1
448	31604	O-RING	2
449	24229	O-RING	1
450	27925	RETAINING RING	1
451	105148	THRUST WASHER	1
452	103176	NEEDLE ROLLER BEARING	1
453	83112	CLUTCH CARRIER ASSY (REFER TO PAGE 12)	1
454	103179	THRUST WASHER	1
455	103178	NEEDLE ROLLER BEARING	1
456	103975	THRUST WASHER	1
457	105143	RING GEAR	1
458	105239	COVER	1
459	25108	O-RING	2
460	73294	THRUST RACE	2
461	24305	BEARING	1
462	104075	PRIMARY SUN GEAR	1
463	102474	CAPSCREW, HEX SOCKET HD (1/2-13 X 3/2, G8, Z)	4
464	105637	BALL BEARING	1
465	PA7M1250	RETAINING RING	1

**CARRIER CLUTCH ASSEMBLY
H60VS**

ITEM NO.	PART NO.	DESCRIPTION	QTY.
--	82920	CARRIER CLUTCH ASSEMBLY	1
1	104077	CARRIER CLUTCH	1
2	104076	PLANET GEAR	3
3	25614	PLANET GEAR SHAFT	3
4	24175	ROLLING BEARING	3
5	25361	BEARING RACE	6
6	24113	ROLL PIN	3
7	101377	BRAKE PLATE	7
8	101378	FRICTION DISC	6
9	103182	WAVE SPRING	5
10	102803	THRUST RING	1
11	26147	RETAINING RING	1

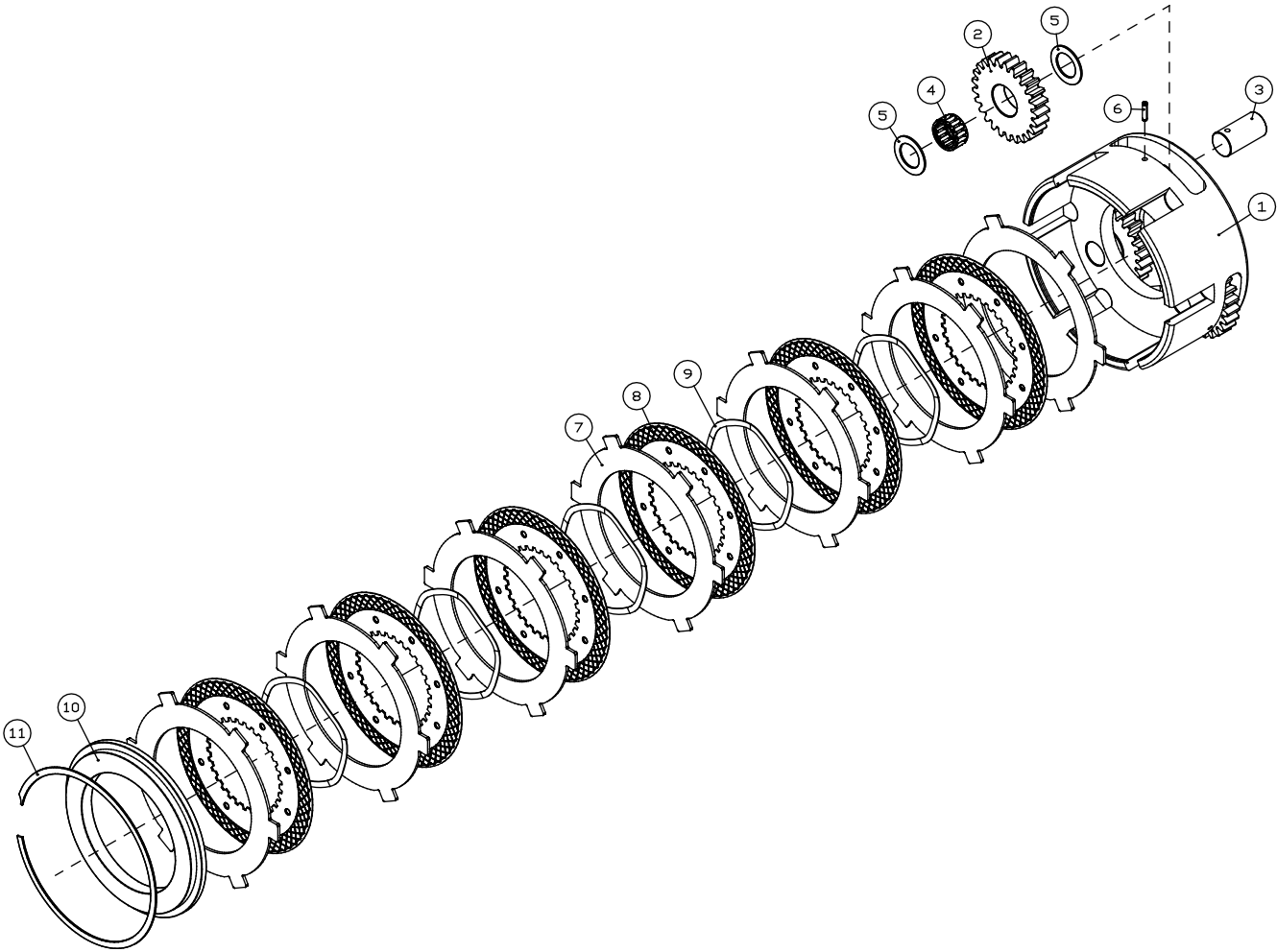

**SPRAG CLUTCH ASSEMBLY
H60VS**

ITEM NO.	PART NO.	DESCRIPTION	QTY.
--	81776	SPRAG CLUTCH ASSEMBLY	1
49	NSS	OUTER BRAKE RACE	1
50	NSS	INNER BRAKE RACE	1
51	27684	SPRAG BEARING	2
52	24581	THRUST BEARING	2
53	12034	RETAINING RING	2
54	NSS	SPRAG CLUTCH	1
55	24506	RETAINING RING	1

NSS - NOT SERVICED SEPARATELY

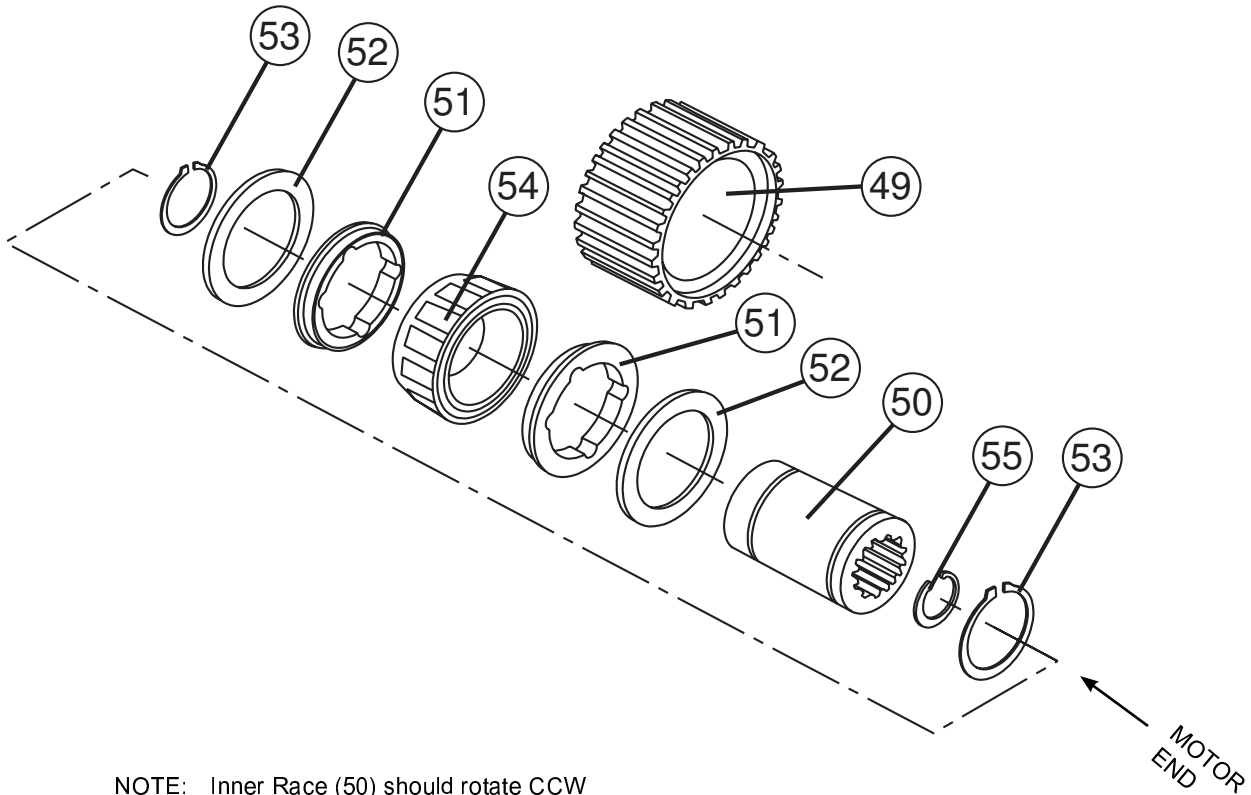

NOTE: Inner Race (50) should rotate CCW when viewed from Motor End.

THIS PAGE INTENTIONALLY LEFT BLANK

**CABLE DRUM GROUP
H60VS**

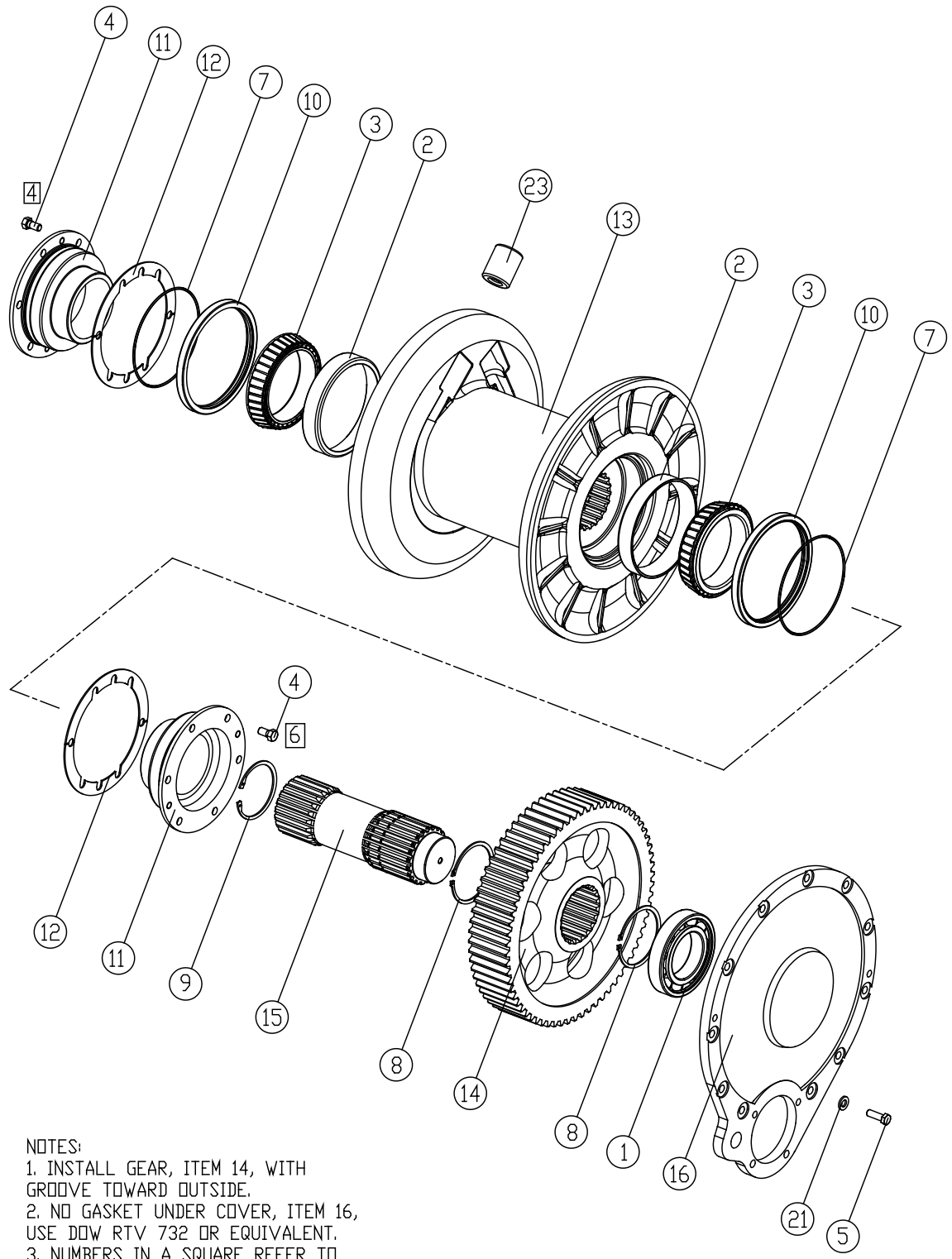

NOTES:
 1. INSTALL GEAR, ITEM 14, WITH GROOVE TOWARD OUTSIDE.
 2. NO GASKET UNDER COVER, ITEM 16, USE DOW RTV 732 OR EQUIVALENT.
 3. NUMBERS IN A SQUARE REFER TO QUANTITY AT THAT LOCATION.

**CABLE DRUM GROUP
H60VS**

ITEM NO.	PART NO.	DESCRIPTION	QTY.
1	70070	BALL BEARING	1
2	70078	BEARING CUP	2
3	70079	BEARING CONE	2
4	27745	CAPSCREW, HEX HD (½-13 X 1, G5, SS)	10
5	104322	CAPSCREW, HEX HD (½-13 X 1½, G5, Z)	11
7	70140	O-RING	2
8	70513	RETAINING RING	2
9	70164	RETAINING RING	1
10	70167	SEAL	2
11	27311	BEARING CARRIER, RH	2
12	70264	SHIM SET (1 pair each, .005, .007, .020 in. (.13, .18, .51 mm))	1-2 AR
13	69998	CABLE DRUM	1
14	68863	SECOND REDUCTION GEAR	1
15	69988	SECOND REDUCTION GEAR SHAFT	1
16	28954	BEARING CARRIER	1
21	100859	WASHER, HARD (½)	11
23	29424	FERRULE - ¾ in. (20 mm) WIRE ROPE	AR
	29425	FERRULE - 7/8 in. (22 mm) WIRE ROPE	AR
	29426	FERRULE - 1 in. (25 mm) WIRE ROPE	AR

SS - SELF SEALING

AR - AS REQUIRED

IDLER SHAFT GROUP H60VS

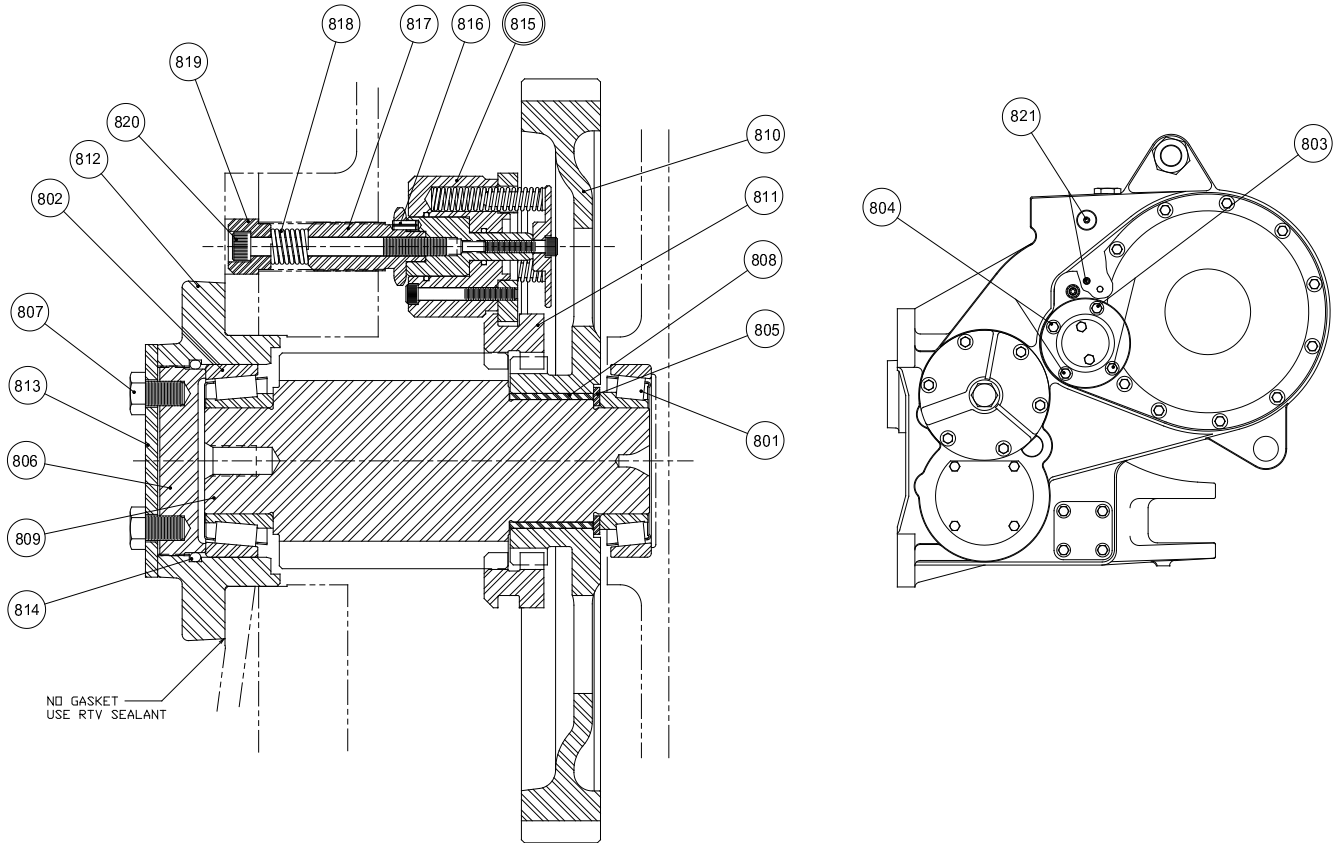

ITEM	PART NO.	DESCRIPTION	QTY.
801	69013	BEARING ASSEMBLY	1
802	69014	BEARING ASSEMBLY	1
803	104174	CAPSCREW, HEX HEAD (1/2 - 13 X 1-1/4) GD 8, Z	2
804	29855	CAPSCREW, HEX HEAD (1/2 - 13 X 2) GD 8, Z	2
805	11892	THRUST WASHER	1
806	69592	ADJUSTER	1
807	103250	CAPSCREW (1/2 - 13 X 3/4) GD 8, Z	2
808	70349	BUSHING	1
809	69984	SECOND REDUCTION PINION	1
810	101055	FIRST REDUCTION GEAR	1
811	69979	CLUTCH COLLAR	1
812	69974	CARRIER	1
813	69655	LOCK PLATE	1
814	25880	O-RING	1
815	82320	FREESPOOL CYLINDER ASSEMBLY - (REFER TO PAGE 18)	1
816	12026	ROLL PIN	1
817	100810	CYLINDER STUD	1
818	24916	SPRING	1
819	100812	BOLT RETAINER	1
820	102309	CAPSCREW, SOC. HEAD (3/8 - 16 X 4-1/4)	1
821	25915	SET SCREW, SOC. HEAD (1/2 - 20 X 1)	2

Note: No gasket used under carrier [12]. Use RTV silicone sealant.

**FREESPOOL CYLINDER ASSEMBLY
H60VS**

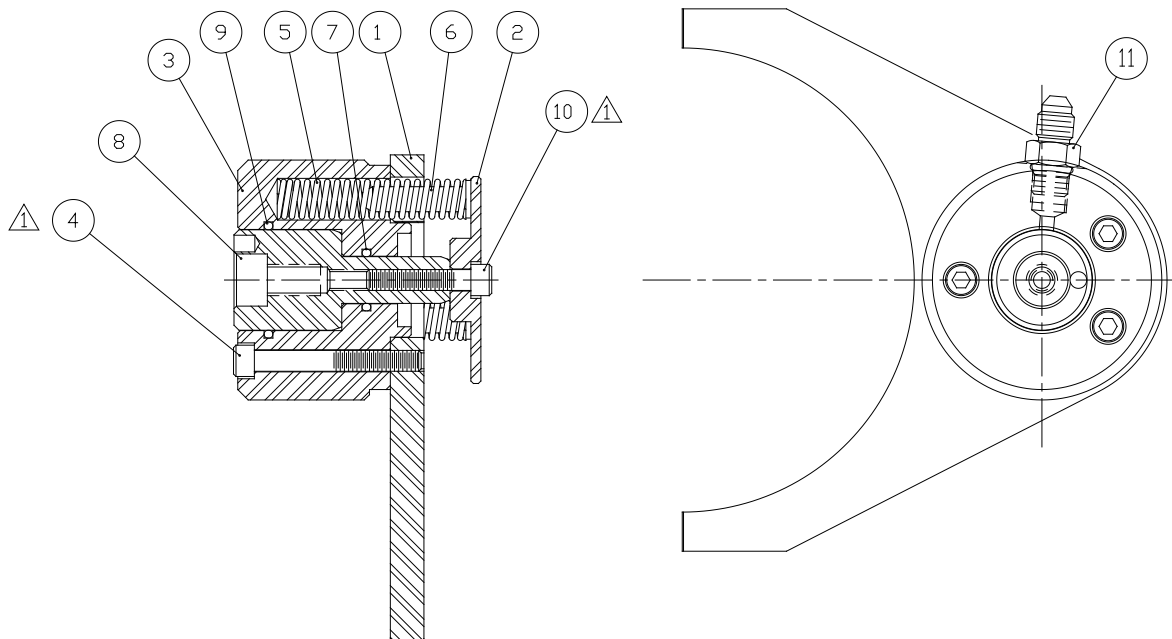

NOTE:

- ① APPLY LOCTITE 242 OR 243 TO CLEAN DRY THREADS OF ITEMS 4 & 10 AND TIGHTEN TO 13 LB·FT (18 N·m)

ITEM	PART NO.	DESCRIPTION	QTY.
--	82320	FREESPOOL CYLINDER ASSEMBLY (COMPLETE)	1
1	100804	YOKE	1
2	100805	CYLINDER RETAINER	1
3	100806	FREESPOOL CYLINDER	1
4	100823	CAPSCREW, SOC. HEAD (¼ - 20 x 2 GD 8, Z)	3
5	100807	SPRING	3
6	100808	SPRING GUIDE	3
7	72097	O-RING	1
8	100809	CYLINDER ROD	1
9	23633	O-RING	1
10	101511	CAPSCREW, SOC. HEAD (¼ - 20 x 1-¼ GD 8, Z)	1
11	25864	ADAPTER	1

**FOURTH SHAFT GROUP
H60VS**

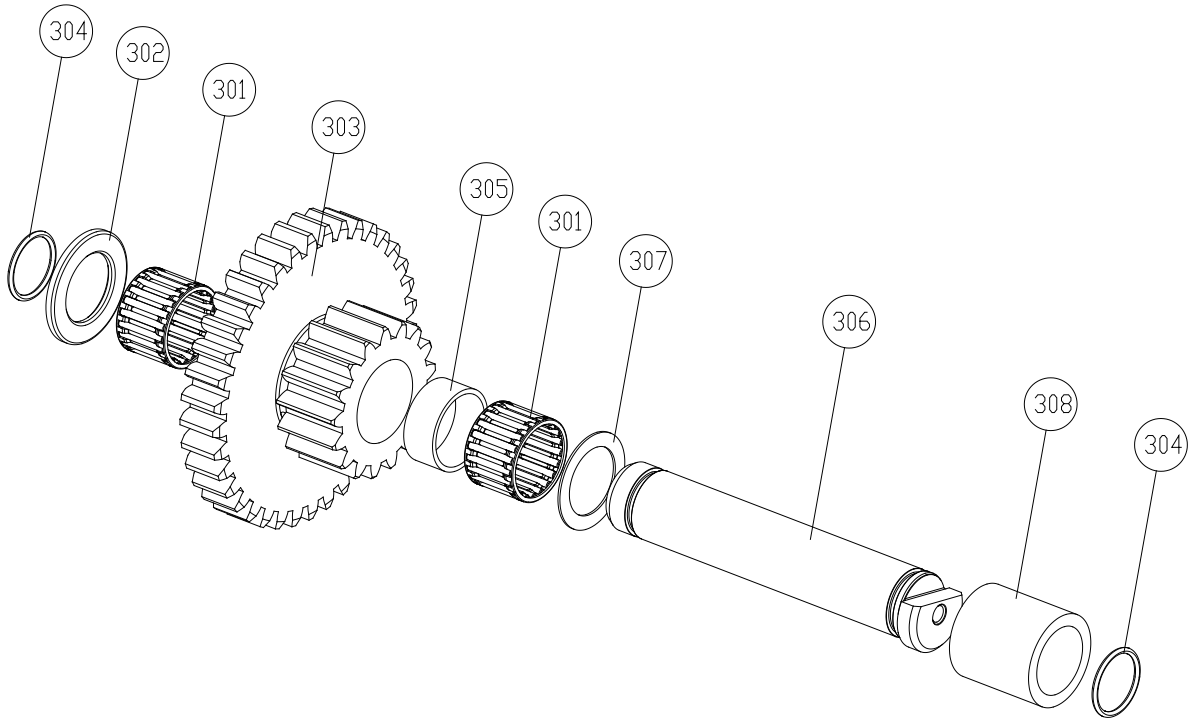

ITEM	PART NO.	DESCRIPTION	QTY.
301	70648	ROLLER BEARING	2
302	28924	THRUST WASHER - .217 in. (5.5 mm)	1
303	28925	CLUSTER GEAR 37/17 TEETH	1
304	13838	O-RING	2
305	28926	SPACER	1
306	105145	COUNTERSHAFT PIN	1
307	24581	THRUST WASHER - .062 in. (1.58 mm)	1
308	105144	SPACER	1

FAIRLEAD ASSEMBLY

Standard 3-roller fairlead consists of two vertical rollers, and one horizontal roller in the top position.

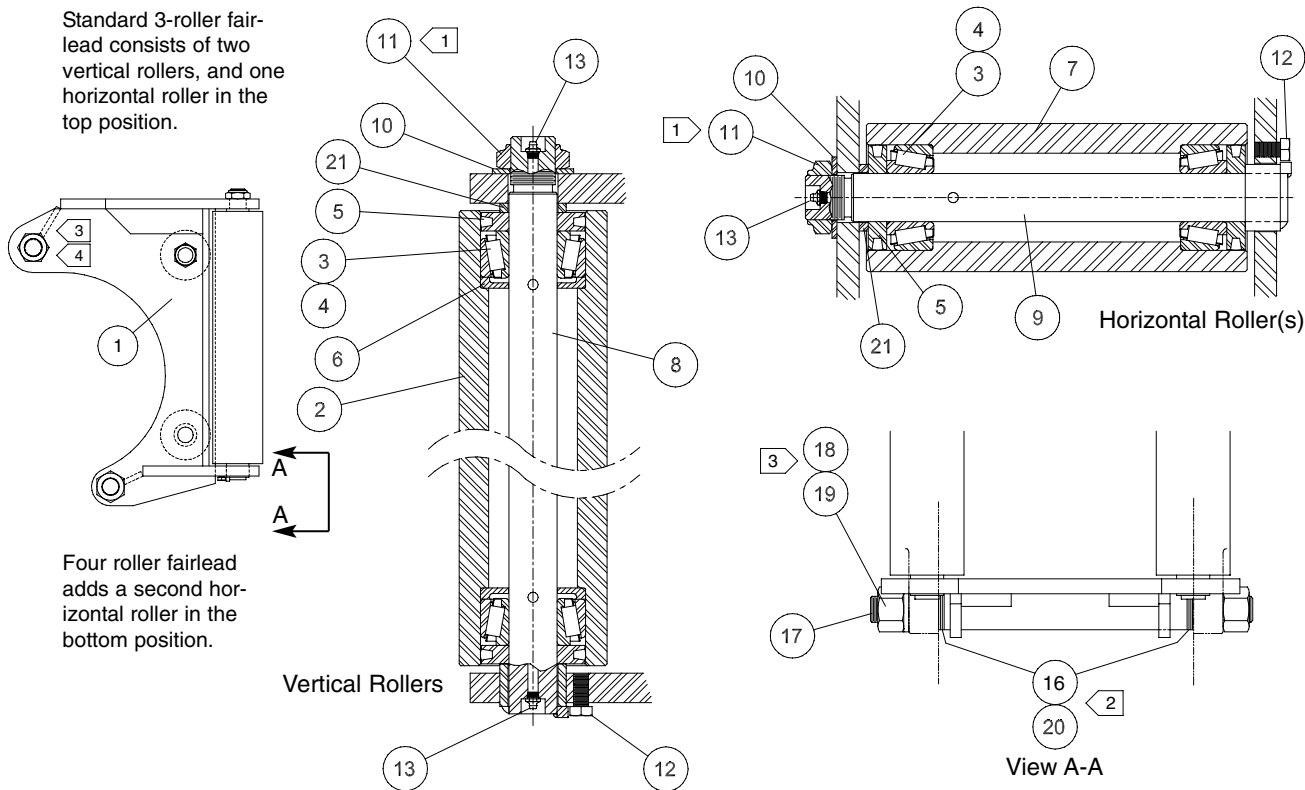

Four roller fairlead adds a second horizontal roller in the bottom position.

NOTES:

- 1 WHILE TURNING ROLLER, TIGHTEN NUT. WHEN ROLLER WILL NO LONGER TURN, BACK OFF NUT 1/8 TURN.
- 2 SHIM BOTH SIDES AS REQUIRED TO REDUCE END PLAY TO LESS THAN 0.030 in. (0.8 mm).
- 3 TIGHTEN NUT TO 200 - 300 LB•FT (271 - 407 N•m) TORQUE.
- 4 WHEN INSTALLING FAIRLEAD ON WINCH IN FIELD, REMOVE ORIGINAL CABLE GUARD SPACER TUBE AND RE-USE UPPER TIE BOLT (28772), LOCKWASHER (27666) AND NUT (27655).

THOROUGHLY PACK ALL FAIRLEAD BEARINGS WITH MULTI-PURPOSE GREASE ON ASSEMBLY.

ITEM NO.	PART NO.	DESCRIPTION	QUANTITY	
			3 ROLLER	4 ROLLER
	81970	3 ROLLER FAIRLEAD ASSEMBLY		
	81971	4 ROLLER FAIRLEAD ASSEMBLY		
1	27817	FAIRLEAD FRAME	1	1
2	36788	ROLLER - VERTICAL	2	2
3	70833	BEARING CONE	6	8
4	70834	BEARING CUP	6	8
5	70864	DUST GUARD ASSEMBLY	6	8
6	70865	GREASE RETAINER	4	4
7	27886	ROLLER - HORIZONTAL	1	2
8	36797	SHAFT - VERTICAL	2	2
9	27901	SHAFT - HORIZONTAL	1	2
10	70850	WASHER	3	4
11	70863	LOCK NUT	3	4
12	22729	CAPSCREW, HEX HEAD (1/2 - 13 X 3/4)	3	4
13	18047	GREASE FITTING	5	6
16	24912	WASHER - .030 in. (.8 MM)	5	6
17	28772	TIE BOLT	1	1
18	27666	LOCK WASHER (1 3/4)	1	1
19	27655	NUT, HEX (1 3/4 - 5)	1	1
20	25590	SHIM - .125 in. (3.18 mm)	6-AR	6-AR
21	70880	SPACER	3	4
	82751	4TH ROLLER KIT, CONTAINS ONE EACH 7, 9, 10, 11, 12, 13, 21 AND TWO EACH 3, 4 & 5	1	--

AR - AS REQUIRED