

PACCAR WINCH DIVISION

MODEL PA56

for Caterpillar D6G PS Tractors

SERVICE MANUAL

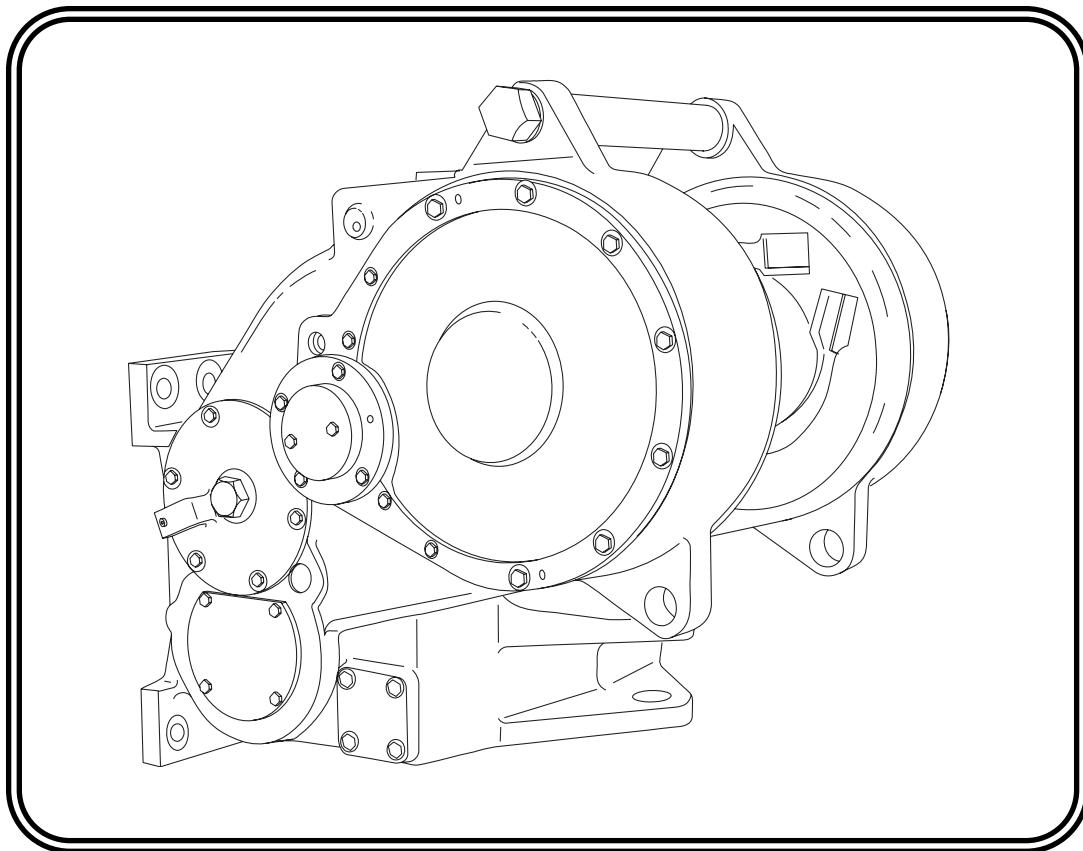

FOREWORD

Please read and understand this entire manual BEFORE operating or performing service on your PACCAR winch. Retain this publication for future reference.

This manual contains instructions for the service and repair of PACCAR Model PA56 power shift winch.



Some illustrations in this manual may show details or attachments that may be different from your winch. Also, some components may have been removed for clarity.



Continuing product improvements may cause changes in your winch, which are not included in this manual. Whenever a questions arises regarding your PACCAR winch or this publication, please contact the PACCAR Service Department at 1-918-251-8511, Monday - Friday, 0800 hrs - 1630 hrs CST, or by fax at 1-918-259-1575, or by e-mail at winch.service@paccar.com. Provide the complete winch MODEL NUMBER and SERIAL NUMBER when making inquiries.

TABLE OF CONTENTS

GENERAL SAFETY RECOMMENDATIONS	2
MODEL DESCRIPTION	3
PREVENTIVE MAINTENANCE & SPECIFICATIONS	4
BASIC WINCH OPERATION AND TROUBLE SHOOTING	8
WINCH REMOVAL AND INSTALLATION	14
WIRE ROPE INSTALLATION & WELDING PROCEDURE	16
BEVEL PINION & HYDRAULIC PUMP SERVICE	17
CLUTCH SHAFT SERVICE	21
CLUTCH ASSEMBLY SERVICE	28
BRAKE ASSEMBLY SERVICE	31
IDLER SHAFT GROUP	34
FOURTH SHAFT GROUP	37
CABLE DRUM GROUP	39
CONTROL VALVE SERVICE	42
ACCUMULATOR SERVICE	49

Safety and informational callouts used in this manual include:

 WARNING 
WARNING - This emblem is used to warn against hazards and unsafe practices that COULD result in severe personal injury or death if proper procedures are not followed.

 CAUTION 
CAUTION - This emblem is used to warn against potential or unsafe practices that COULD result in personal injury and product or property damage if proper procedures are not followed.



This emblem is used to indicate an informational note or service tip.

GENERAL SAFETY RECOMMENDATIONS

Safety for operators and ground personnel is of prime concern. Always take the necessary precautions to ensure safety to others as well as yourself. To ensure safety, the tractor and winch must be operated with care and concern by the operator for the equipment, and a thorough knowledge of the machine's handling and performance capabilities. The following recommendations are offered only as a guide for the operator. Local rules and regulations will also apply.

WARNING

Failure to obey the following safety recommendations may result in property damage, injury or death.

1. Read all warning tag information and become familiar with all controls **BEFORE** operating the winch.
2. Never attempt to clean, oil or perform any maintenance on the winch with the tractor engine running, unless specifically instructed to do so in this manual.
3. Before starting the tractor engine, be certain all controls move freely and are placed in the "Brake On" (neutral) position.
4. Never operate the winch controls unless you are properly seated at the operator's station on the tractor and you are sure all personnel are clear of the work area.
5. Never attempt to handle winch cable when the hook end is not free. Keep all parts of body and clothing clear of winch drum, cable rollers and entry area of fairleads and arches.
6. Ground personnel should stay in clear view of the tractor operator and clear of the winch drum. Do not allow ground personnel near a winch line under tension. A safe distance of 1 ½ times the working length of the cable should be maintained. Never allow anyone to stand under a suspended load.
7. Avoid sudden "shock" loads or attempting to "jerk" a load free. This type of operation may cause heavy loads in excess of the rated winch capacity, which may result in the failure of the cable and/or winch.
8. Use only GENUINE PACCAR parts. Do not use parts from other winch manufacturers on your PACCAR winch. Do not use PACCAR parts on winches from other manufacturers.
9. Use the correct size ferrule for the cable and pocket in the winch drum. Never use knots to secure or attach cable to the winch drum, or the hook to the cable. The cable anchor or ferrule pocket in the cable drum is designed to provide a self release in the event a back-sliding load must be released from the tractor in an emergency situation. The cable anchor or ferrule alone will NOT support the rated capacity of

the winch. Therefore, a minimum of five (5) complete wraps must be maintained on the winch drum.

 **NOTE:** *We suggest painting the last five wraps of cable bright red to serve as a visual warning.*

RECOMMENDED OPERATING PRACTICES

1. Leather gloves should be used when handling winch cable.
2. Operate the winch to match line speeds to job conditions.
3. Assure that personnel who are responsible for hand signals are clearly visible and that the signals to be used are thoroughly understood by everyone.
4. Inspect winch cable, rigging, winch and tractor at the beginning of each work shift. Defects should be corrected immediately.
5. Position the tractor for the straightest line of pull to reduce the wear on the winch cable and ensure even spooling.
6. When winding winch cable on the winch drum, never attempt to maintain tension by allowing the winch cable to slip through the hands. Always use the "hand-over-hand" technique, being careful to keep hands and clothing away from winch drum and fairlead rollers.
7. Be sure of tractor ground stability before winching in a load.
8. Store unused chokers, slings and rigging in a neat and orderly fashion to prevent damage to equipment or injury to personnel.
9. Do not operate the winch under loads that exceed the maximum rated bare drum line pull. If excessive loads are encountered, use a multi-part line and sheave blocks. Any attempt to exceed the capacity of one winch (such as coupling 2 or more tractors together) is extremely hazardous.
10. The factory approved adaptations for PACCAR winches are designed and intended for use on specific models of crawler tractors. Changing winches between tractors is not possible in some cases

because of differences in tractor models. Some changes cannot be approved by PACCAR because of safety limitations. Call a PACCAR dealer or the PACCAR factory prior to attempting winch modifications or before mounting on a different tractor.

11. Discharge all retained hydraulic system pressure BEFORE removing any hydraulic lines or fittings. Personal injury may result from sudden release of oil pressure. To discharge the winch control system pressure, stop the tractor engine and cycle the winch control lever into all positions five (5) times.
12. On machines having hydraulically, mechanically and/or cable controlled equipment, be certain the equipment is either lowered to the ground or blocked securely before servicing, adjusting and/or repairing the winch. Always apply the tractor parking brakes and lower any equipment to the ground before dismounting the tractor.

13. The winches described in this manual are neither designed nor intended for use or application in the lifting or moving of persons.
14. Install guarding to prevent personnel from getting any part of their body or clothing caught at a point where the cable is wrapped onto the drum or drawn through the fairlead rollers.
15. Keep equipment in good operating condition. Perform the scheduled servicing and adjustments defined in the "Preventive Maintenance" section of this manual. Use of proper lubricants is crucial.
16. An equipment warm-up procedure is recommended for all tractor start-ups, and is essential at ambient temperatures below +40°F (+5°C). Refer to the "Warm-Up Procedure" listed in the "Preventive Maintenance" section of this manual.

MODEL DESCRIPTION

The PACCAR Power Shift Winch is a single drum unit which mounts on the rear of a crawler tractor. It is driven by engine power through the tractor PTO (Power Take-Off). The winch may be operated independently or with the tractor transmission engaged. When operated properly, it is capable of utilizing maximum engine horsepower. The winch has equal speed gearing, power-in and power-out, using multiple-disc oil actuated friction clutches and a spring applied hydraulically released multiple disc oil brake.

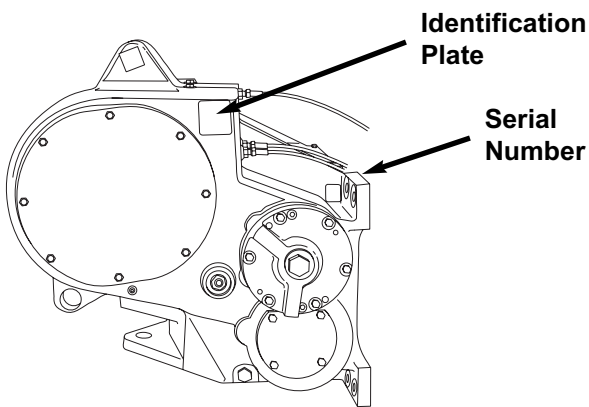

The winch model number is an important reference as to what optional components were used when the winch was manufactured. The winch identification plate is located on the right hand side of the winch case. The serial number is also stamped into the upper right hand mounting pad.

Important: Always refer to the serial number and model number when requesting information or service parts.

The winch model number contains the following configuration data:

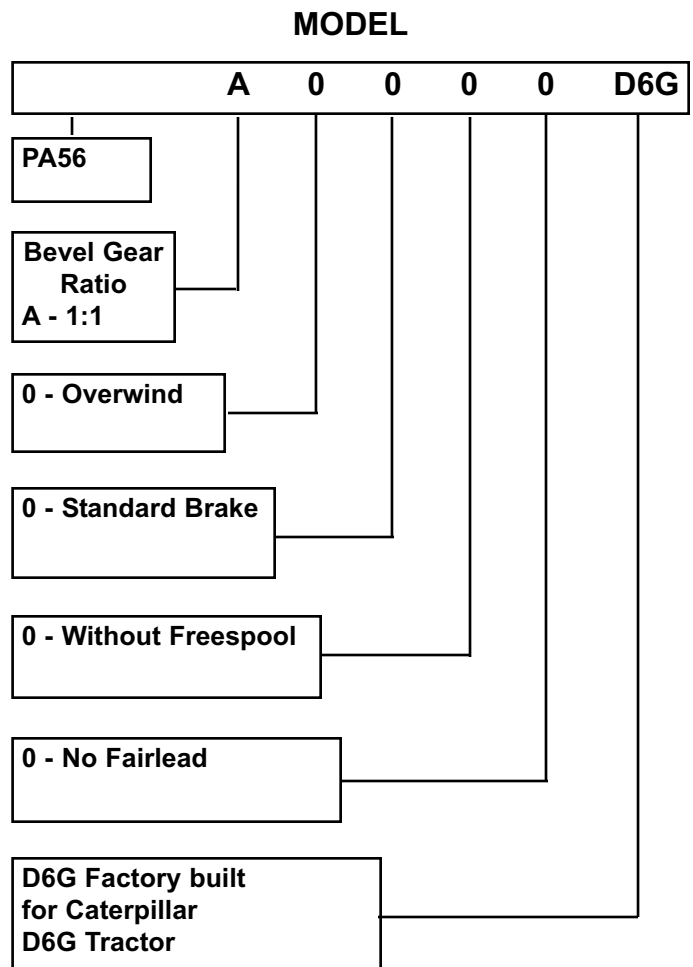

PREVENTIVE MAINTENANCE & SPECIFICATIONS

A regular program of preventive maintenance for your PACCAR winch will minimize the need for emergency servicing and promote long product life and trouble-free service.

The service intervals suggested in this manual will optimize component service life. The intervals may be gradually increased or decreased with experience of a particular lubricant and evaluation of your application.

⚠ WARNING ⚠

Discharge accumulator oil supply before removing any hydraulic lines or servicing winch. Personal injury may result from sudden release of oil under pressure. To discharge the accumulator, stop engine, slowly cycle Power Shift control handle into full Reel-In position then full Reel-out position, a minimum of five (5) times.

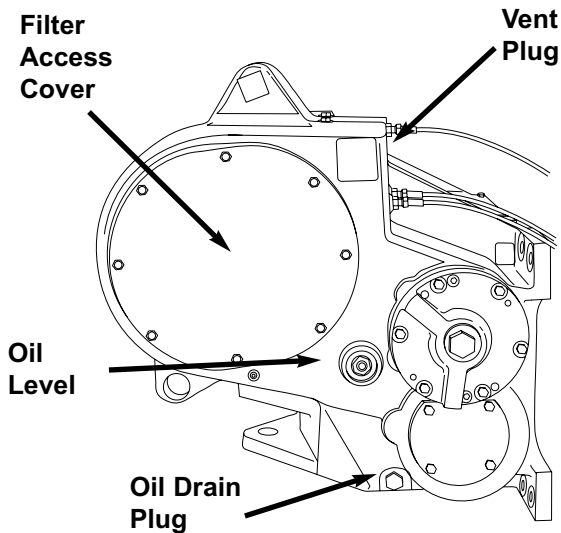

1. Oil Level

Check oil level at the beginning of each work shift, with tractor and winch in level position. Oil must be visible in the upper half of the sight gauge. If an oil level plug is used in place of the sight gauge, the oil level should be at the bottom of the level plug hole. Add oil as required through the fill plug at top of winch case.

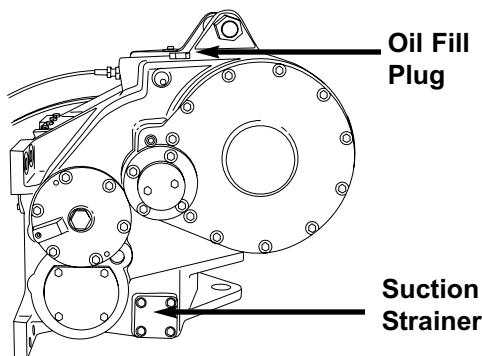

2. Oil Change, Filter and Strainer Service

Under normal operating conditions, the oil and pressure circuit filter should be changed and suction strainer cleaned after the first 100-250 hours of operation, then every 1000 hours or six months, whichever occurs first, or when the filter bypass indicator light remains on after initial warm up.

⚠ WARNING ⚠

Hot oil may cause severe injury. Make certain the oil has cooled to a safe temperature (less than 110°F or 43°C) before servicing.

To drain oil, place tractor and winch in level position and remove drain plug located at lower right hand side of winch case. Drain oil into a suitable container and recycle or dispose of used oil in an environmentally responsible manner. Install plug securely after oil has been drained. After oil has drained, remove four suction strainer cover capscrews and cover. Remove suction strainer from winch case then remove metal band and magnetic rods from suction strainer. Thoroughly wash strainer in clean safety solvent and blow dry with compressed air, inspect wire mesh for damage or clogging with debris. Do not reuse a damaged suction strainer.

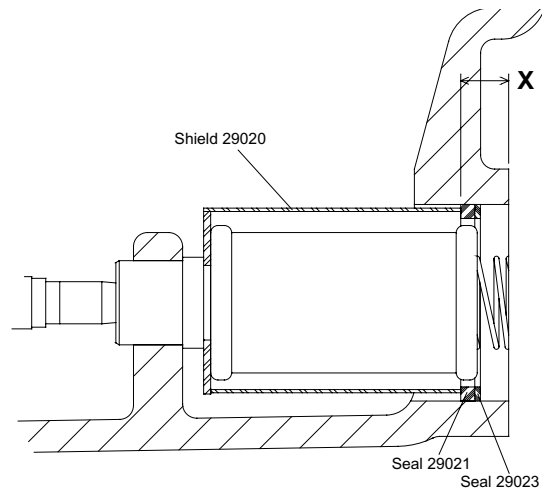
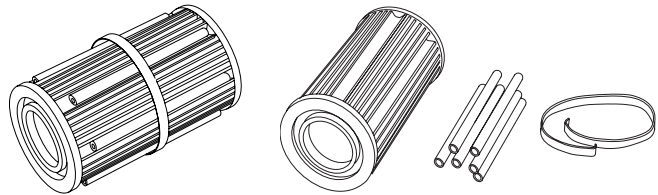

i **NOTE:** If the suction strainer shield or shield seal rings are removed for any reason, reinstall them by following the procedure listed below:

1. Install shield. Part Number 29020, between connector and strainer as shown above, with open side facing downward.
2. Measure distance "X", from shield to strainer cover mounting surface.
3. If "X" dimension is between 0.720 in. and 0.783 in. (18.3 – 19.9 mm), add one seal, 29023, outboard of seal 29021.
4. If "X" dimension is greater than 0.783 in. (19.9 mm), add two seals, 29023, outboard of seal 29021.

Seal 29021 is .25 in. (6.4 mm) thick
 Seal 29023 is .06 in. (1.5 mm) thick

Install magnetic rods onto suction strainer using metal band. Lubricate o-ring and install in groove on cover. Install strainer, spring and cover into winch case.

Refill winch to proper level with recommended oil.



CAUTION

To prevent serious damage to the winch, DO NOT run engine while oil is drained from the winch.

The pressure filter is located behind the right hand, eight-bolt access cover. Remove the cover, locate the spin-on pressure filter and remove the filter element with a strap wrench.

Lubricate the filter gasket and adapter threads with winch oil and install new filter element onto filter head. Tighten ½ - ¾ turn after seal ring makes contact with filter head.

Start tractor and operate engine at low idle. Correct any leaks.

The filter bypass indicator light may come on for a short time during initial cold start-up but should go out as the oil warms up. If the light stays on, this indicates a restricted filter element, sending unit stuck in the bypass position or accidentally grounded sending unit wire.

3. Control Cable and Pressure Adjustment

While the access cover is removed, it is advisable to check control cable adjustment and hydraulic main relief pressure. Place the Power Shift control lever in the center "Brake-On" (neutral) position. Install the yoke pins into the cable yokes/control valve spools and secure with hitch pins. The yoke pins should slip easily into the bores without any binding. The control valve spools are spring centered. If you notice any binding, turn the cable adjusters in or out until you obtain a "free pin" condition.

Make certain accumulator stored oil supply has been discharged as described earlier. Install an accurate 0-600 psi (0-4137 kPa) gauge onto the – 4 J.I.C. gauge port next to the control cables. Start tractor and operate engine at approximately 800-1000 RPM until pressure

stabilizes. Maximum pressure during "charging" mode should peak at 400 psi (2758 kPa). Pressure will slowly fall back approximately 15-20% from the relief setting then quickly return to 400 psi (2758 kPa) when the valve cycles.

If adjustment is required, locate the adjustment screw hole behind port "P" of the control valve. With a ¼ in. Allen key, loosen the outer lock screw. Insert a 3/16 in. Allen key through the lock screw and turn the adjusting screw clockwise to increase peak pressure; counterclockwise to decrease peak pressure. Tighten the lock screw.



TIP: *If may be helpful to place the controls in Brake-Off to use some oil in the control circuit and cause the valve to slowly "cycle" so that peak pressure may be more easily observed.*

Stop engine, discharge accumulator stored oil supply as described earlier and move hydraulic gauge to the "B" test port on the brake housing. A ¼ in. NPT adapter will be required.

Start tractor and operate engine at approximately 800-1000 RPM. Place Power Shift lever in the Brake-Off position and observe BRAKE-RELEASE oil pressure. Loosen cable adjuster or cable yoke jam-nut and adjust brake control cable to achieve approximately 300 PSI BRAKE-RELEASE pressure.

Stand away from service access of winch and return Power Shift lever to the Brake-ON (neutral) position. BRAKE RELEASE pressure must return to 0 with the controls in BRAKE-ON (neutral) position.



TIP: *Optimum BRAKE-RELEASE pressure is the highest pressure you can achieve while ensuring pressure ALWAYS drops to 0 when controls are returned to BRAKE-ON. Excessive heat and accelerated brake and hydraulic component wear will result if BRAKE-RELEASE pressure does not return to 0.*

With control in Brake-On (neutral) remove gauge from "B" port and securely install plug into brake housing.

Reinstall the filter element as described earlier.

Install access cover plate and tighten eight ½ in. cap-screws/nuts to 75 lb•ft. (102 N•m) torque.

4. Vent Plug

It is very important to keep this vent clean and unobstructed. Whenever the oil is changed, remove vent plug, clean in safety solvent and reinstall. Do not replace with a solid plug.

5. PTO Shaft

The PTO shaft u-joints, slip-joint, flanges and fasteners must be inspected, tightened and lubricated as required at least once every three months or 500 tractor hours, whichever occurs first.

Inadequate PTO shaft maintenance may result in the accelerated wear of the PTO shaft, U-joint, bearings and the adapter gear box components.

CAUTION

Maintenance of the PTO shaft assembly is essential to reliable winch operation. As the PTO shaft turns at approximately engine speed and torque, a failure of a u-joint, shaft or adapter gear box component may result in property damage or injury.

6. Winch Cable (wire rope)

Inspect entire length of wire rope, chokers and hooks according to wire rope and rigging manufacturers recommendations.

7. Mounting Fasteners

Check/tighten all winch mounting fasteners to recommended torque after the first 100-250 hours of operation, then every 1000 operating hours or six (6) months, whichever occurs first.

8. Warm-Up Procedure

Start tractor engine and operate at low idle for five minutes.

WARNING

A warm-up procedure is recommended at each start-up and is essential at ambient temperatures below +40°F (4°C). Failure to warm-up winch hydraulic system may result in erratic clutch/brake operation which may result in property damage, injury or death.

RECOMMENDED OIL

We have published the following specifications to help you determine which lubricant is best suited to your application. Your lubricant supplier should assure you his product meets this specification. If there is any doubt as to the suitability of a lubricant, contact the Carco Winch Service Department, providing a detailed copy of the product specifications.

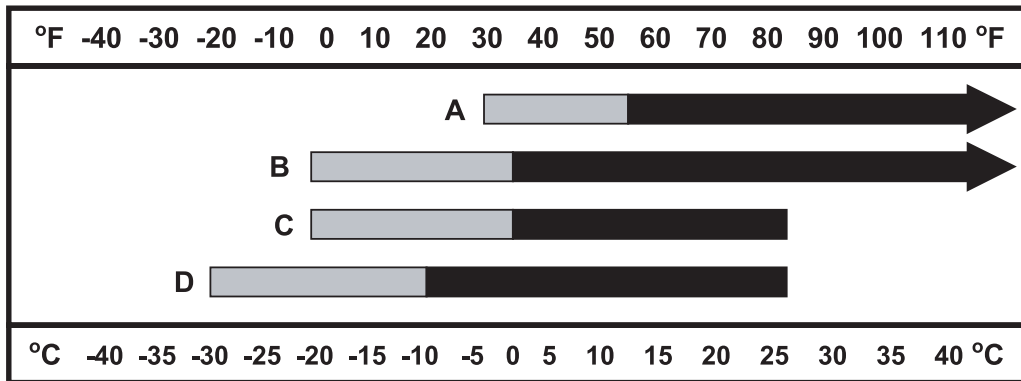

- A - HTF Type C3/C4 SAE 30, CAT TO4 SAE 30
- B - CAT TO4 SAE 10W30
- C - HTF Type C3/C4 SAE 10, CAT TO4 SAE 10W
- D - CAT TO4 SAE 5W20 spc.

WARNING

Cold start-up in this ambient temperature range requires extended equipment warm-up to prevent erratic clutch and brake operation which may result in property damage, injury or death.

Basic Oil Requirements

15,000 SUS maximum allowed viscosity at cold start-up; requires extended equipment warm-up. 3,000 SUS maximum allowed viscosity at cold start-up; requires normal equipment warm-up. 60 SUS minimum allowed viscosity at maximum winch operating temperature, assuming ambient plus 80°F (27°C).

Oil must possess high temperature oxidation stability, rust corrosion protection, good dispersant and detergent characteristics, anti-wear additives and remain compatible with nitrile base seals.

SPECIFICATIONS

Unit weight (without oil, cable or specific tractor adapters)2,400 lbs (1,090 kg)

Gear Ratio Available

Bevel Gear Ratio	1.00:1				
Overall Ratio (4-Shaft Gear Train)	40.4:1				

Cable Drum Dimensions	
Barrel Diameter	11.5 in. (292 mm)
Flange Diameter	19-7/8 in. (505 mm)
Barrel Length	13 in. (330 mm)
Throat Clearance	approx. 9 in. (229 mm)

Cable Storage Capacity	
1 in. (25 mm)	180 ft. (55 m)
1-1/8 in. (28 mm)	115 ft. (35 m)

Cable Ferrule Part Numbers	
1 in. (24 mm)	29426

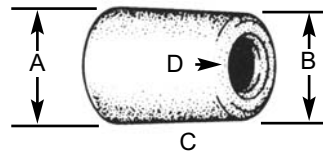

Cable Ferrule Dimensions
 A - 2-3/16 in. (56 mm)
 B - 2-1/32 in. (52 mm)
 C - 2-5/8 in. (67 mm)
 D - To match cable diameter

Hydraulic System

Oil Capacity - 78 qt (74 L)
 Differential Unloading Valve Cut-out Pressure390-410 psi (2,690-2,830 kPa)
 Typical Operating Oil Temperature Up to Ambient Plus 80°F (26.7°C)

RECOMMENDED FASTENER TORQUE

The general purpose torque shown in the chart applies to SAE Grade 5 bolts, studs and standard steel full, thick and high nuts.

Higher or lower torque values for special applications will be specified; such as the use of spanner nuts, nuts on shaft ends, jam nuts and where distortion of parts or gaskets is critical.

Lubricated torque values based on use of SAE 30wt engine oil applied to threads and face of bolt or nut.

Avoid using thread lubricants as the applied torque may vary by 10 - 40%, depending upon the product used.

Bolt Dia. Inches	Thds Per Inch	Torque (LB-FT)			
		Grade 5		Grade 8	
		Dry	Lubed	Dry	Lubed
1/4	20	8	6	12	9
	28				
5/16	18	17	13	24	18
	24				
3/8	16	31	23	45	35
	24				
7/16	14	50	35	70	50
	20				
1/2	13	75	55	110	80
	20				
9/16	12	110	80	150	110
	18				
5/8	11	150	115	210	160
	18				

Bolt Dia. Inches	Thds Per Inch	Torque (LB-FT)			
		Grade 5		Grade 8	
		Dry	Lubed	Dry	Lubed
3/4	10	265	200	380	280
	16				
7/8	9	420	325	600	450
	14				
1	8	640	485	910	680
	14				
1 1/8	7	790	590	1290	970
	12				
1 1/4	7	1120	835	1820	1360
	12				
1 3/8	6	1460	1095	2385	1790
	12				
1 1/2	6	1940	1460	3160	2370
	12				

To convert lb•ft to kg•m, multiply lb•ft value by 0.1383.

BASIC WINCH OPERATION AND TROUBLE SHOOTING

HYDRAULIC SYSTEM

The winch contains an independent, internal hydraulic system. The winch housing serves as a reservoir and stores filtered oil for the internally mounted hydraulic pump. The pump is driven by a gear pressed onto the bevel pinion gear. The pump supplies oil whenever the PTO shaft is turning. Oil from the pump is routed through a pressure filter then directed to the control valve where a stand-by system pressure is maintained at 320-410 psi (2200-2830 kPa).

The system oil pressure is routed through the control valve body to the Directional and Brake control cartridges. Movement of the Directional control spool opens passages which direct oil to apply the Reel-In (forward) or Reel-out (reverse) clutches and release the spring applied multi-disc oil brake.

Movement of the Brake spool will direct oil to release the brake only. The movement of the spools responds to the position of the operators Power Shift control lever by means of flexible control cables.

⚠ WARNING ⚠

Discharge accumulator oil supply before removing any hydraulic lines or servicing winch. Personal injury may result from sudden release of oil under pressure. To discharge the accumulator, stop engine, slowly cycle Power Shift control handle into full Reel-In position then full Reel-out position, a minimum of five (5) times.

GEAR TRAIN

The PA56 powershift winch has equal speed gearing, Reel-In and Reel-out, using multiple-disc oil actuated friction clutches and a spring-applied hydraulically released multiple-disc oil brake.

The winch bevel pinion, bevel gears, hydraulic pump and clutch friction discs are rotating whenever the tractor PTO shaft is rotating. Application of a clutch, Reel-In or Reel-

out, and the simultaneous release of the brake will cause the rotation of the remaining gear train and cable drum.

The clutch shaft assembly (with bevel gears) must turn 40.4 times for one (1) rotation of the cable drum.

The direction of the tractor PTO shaft rotation and the right and left hand clutch location is determined by facing the rear of the tractor.

The cable drum rotation may be easily changed from overwind (standard) to underwind by reversing clutch pressure lines at the control valve ports C₁ and C₂ and installing the wire rope in the opposite cable drum ferrule pocket.

TROUBLESHOOTING

If the winch does not operate correctly, perform a visual inspection of obvious faults, such as leaking oil, loose, damaged, or broken parts. If cause of trouble is not readily apparent, check operation of winch in each function to help determine the trouble.

HYDRAULIC TESTS

The main hydraulic test port is located on the right hand side of the winch case next to the control cables. Attach an accurate 0-600 psi (0-4137 kPa) gauge to this port for most hydraulic system tests. The test port requires an SAE-4 JIC hose adapter.

⚠ WARNING ⚠

Discharge accumulator oil supply before removing any hydraulic lines or servicing winch. Personal injury may result from sudden release of oil under pressure. To discharge the accumulator, stop engine, slowly cycle Power Shift control handle into full Reel-In position then full Reel-out position, a minimum of five (5) times.

TROUBLE	PROBABLE CAUSE	CORRECTIVE ACTION
<p style="text-align: center;">A</p> <p>Brake does not hold.</p>	<p>1. Controls not returning to "Brake-On" neutral position.</p> <p>2. Brake assembly worn, damaged or improperly assembled.</p> <p>3. Frequent lowering of loads by slipping through the brake generates excessive heat buildup. This can destroy friction disc material and warp steel plates. Lower loads by placing power shift lever in reverse position.</p>	<p>1a. Inspect control cables for damage and binding; repair or replace as required.</p> <p>1b. Inspect control stand for excessive wear, damage, weak centering springs, or through bolts over-tightened. Repair as required.</p> <p>1c. Adjust control cables.</p> <p>1d. Control valve internal components damaged. Disassemble and repair or replace valve cartridge.</p> <p>2. Remove and disassemble brake assembly to check for worn parts or improper assembly.</p> <p>3a. Remove brake assembly, disassemble and replace friction discs if oil grooves are no longer visible. Replace steel plates if warped or scored.</p> <p>3b. Replace damaged discs and plates. Instruct operator to use Reel-out for lowering of loads.</p>
<p style="text-align: center;">B</p> <p>Winch continues to Reel-In/Reel-out cable with controls in "Brake-On".</p>	<p>1. See probable cause A1.</p> <p>2. Brake worn or damaged and directional clutch damaged with discs warped driving clutch.</p>	<p>1. See corrective action for A1a – d.</p> <p>2. See corrective action for A2 and disassemble clutch assembly to check for damaged parts.</p>
<p style="text-align: center;">C</p> <p>Tractor engine or torque converter stalls when attempting to Reel-In or Reel-out.</p>	<p>1. Brake not releasing as clutch is applied due to low hydraulic pressure. 190-235 psi (1310-1620 kPa) is required to release brake.</p> <p>2. Brake not releasing due to damaged components.</p>	<p>1a. See corrective action for D.</p> <p>1b. Shuttle valves in control valve worn or sticking allowing excessive oil leakage during clutch application. Disassemble valve to inspect components.</p> <p>2. See corrective action for A2.</p>

TROUBLE	PROBABLE CAUSE	CORRECTIVE ACTION
<p style="text-align: center;">D</p> <p>No or very low hydraulic pressure.</p>	<ol style="list-style-type: none"> 1. Low oil level. 2. Tractor torque converter stalls when operating winch. 3. Suction strainer is plugged, cavitating pump. 4. Suction hose damaged, cavitating pump. 5. Defective pump. 6. System relief pressure set too low. 7. Control valve defective. 	<ol style="list-style-type: none"> 1. Fill winch to proper level with recommended oil. 2. Operate tractor engine at proper speed to match winch load requirement. Minimum PTO shaft speed for reliable winch operation is 650 RPM. Use sheave blocks and multi-part line if excessive line pulls are encountered. 3. Drain oil, change pressure filter and clean suction strainer. Fill with new recommended oil. While cleaning suction strainer, identify contamination and take corrective action as required. 4. Drain oil, remove small side inspection covers to permit access to pump suction hose. Inspect hose for cracks and loose connections. Replace as required. 5. Check pump flow reading as outlined in "Pump Service". Identify cause of pump failure and take corrective action prior to installation of new pump. 6. Adjust system relief pressure to 390-410 psi (2689-2827 kPa). 7. Disassemble control valve and check for worn or damaged components. Also see corrective action for K.
<p style="text-align: center;">E</p> <p>Clutch damaged or defective.</p>	<ol style="list-style-type: none"> 1. Friction discs worn and steel discs warped. 2. Clutch piston return springs weak or broken. 3. Clutch piston seized or o-rings defective. 4. Check-ball in clutch housing is stuck open. 5. Clutch assembled with excessive clutch piston travel. 6. Control valve defective. 	<ol style="list-style-type: none"> 1. Replace disc and plates. Adjust system relief pressure to 390-410 psi (2689-2827 kPa). Instruct operator not to "feather" clutch under load. 2. Replace springs as required. 3. Clean and replace components as required. 4. Clean ball and valve seat. Replace components as required. 5. Rebuild clutch as outlined in "Clutch Assembly Service". 6. See corrective action for C1b., D6a, and K.

TROUBLE	PROBABLE CAUSE	CORRECTIVE ACTION
<p style="text-align: center;">F</p> <p>Winch runs hot; above 180°F (82°C).</p>	<p>1. Improper oil level. Too high or too low oil level can cause aeration of oil and overheating.</p> <p>2. Control valve cycling rapidly causing hydraulic components and oil to overheat.</p>	<p>1a. Fill/drain oil to proper level using recommended oil.</p> <p>1b. Make certain oil is not transferring to/from winch and tractor transmission case. Replace PTO/bevel pinion seals as required.</p> <p>2a. Accumulator discharged or bladder ruptured. (see E7b)</p> <p>2b. Control valve defective (see Trouble K).</p>
<p style="text-align: center;">G</p> <p>Winch runs noisy.</p>	<p>1. Improper bevel gear/pinion backlash.</p> <p>2. Defective gear train bearing and/or gear.</p>	<p>1. Establish clutch shaft end play of .005-.010 in. (.13 - .25 mm) and bevel gear/pinion backlash of .004-.012 in. (.10 - .31 mm)</p> <p>2. Replace components. Operate winch within limits, using multi-part line and sheave blocks on excessive line-pull requirements.</p>
<p style="text-align: center;">H</p> <p>Winch gear train bearing and/or gear failure.</p>	<p>1. Defective bearings and/or gear.</p> <p>2. Gear train overloaded or shock loaded.</p>	<p>1. Replace components. Operate winch within limits, using multi-part line and sheave blocks on excessive line-pull requirements.</p> <p>2. Same corrective action as 1. above.</p>
<p style="text-align: center;">I</p> <p>Reel-In and Reel-out functions reversed.</p>	<p>1. CR and CL (C2 and C1) clutch pressure hoses reversed at control valve.</p> <p>If winch will be used in an “underwound” application clutch pressure hoses must be reversed at control valve.</p>	<p>1. Remove right hand access cover and locate control valve. Reverse position of hoses installed at ports CR and CL; ports may also be stamped C1 and C2.</p>

TROUBLE	PROBABLE CAUSE	CORRECTIVE ACTION
<p data-bbox="310 149 334 174">K</p> <p data-bbox="99 201 375 226">Control valve defective.</p>	<p data-bbox="573 149 1032 239">1. System pressure fluctuating as differential unloading valve cycles rapidly when clutch is applied.</p> <p data-bbox="573 260 1032 573">System pressure should rise rapidly to relief pressure, unload pump, and slowly begin to lower. When pressure drops approximately 20% from relief pressure, differential unloading valve will bring pump back into service to charge accumulator circuit back up to relief pressure. The differential unloading valve should not cycle more than once every 20 seconds.</p> <p data-bbox="573 1150 1032 1241">2. System pressure will intermittently rise above adjusted relief pressure and fail to recycle below cut-in pressure.</p>	<p data-bbox="1057 149 1479 336">1a. May be caused by excessive leakage past clutch piston seals, brake piston seals, clutch shaft rotary shaft seals or damaged hoses. Replace defective components as required.</p> <p data-bbox="1057 357 1479 478">1b. Shuttle valve(s) in control valve worn or sticking. Remove shuttle valves for inspection or replacement.</p> <p data-bbox="1057 499 1479 621">If springs are still present, remove and discard springs to improve response time and reduce leakage of shuttle valves.</p> <p data-bbox="1057 642 1479 764">1c. Large accumulator circuit check poppet in top of control valve not seating to hold charge in accumulator.</p> <p data-bbox="1057 785 1479 842">Remove check poppet assembly for inspection or replacement.</p> <p data-bbox="1057 863 1479 1079">1d. Differential unloading pilot cartridge worn allowing leak down of accumulator circuit and fluctuation of pressures. Disassemble cartridge for inspection or replacement. Adjust relief pressure following installation of new components.</p> <p data-bbox="1057 1150 1446 1178">2a. See corrective action for K1a.</p> <p data-bbox="1057 1199 1479 1478">2b. Differential unloading pilot cartridge piston is sticking in bore causing system (accumulator circuit) pressure to rise too high before offseating check-ball, then holding check-ball offseated too long before recycling. Disassemble differential unloading valve cartridge for inspection, repair or replacement.</p> <p data-bbox="1057 1499 1479 1871">2c. Differential unloading poppet sticking in bore causing pump pressure to rise too high before unloading to "T" port, then remaining open to "T" too long before reseating and sending pump flow back to recharge accumulator circuit. Remove differential unloading poppet for inspection of poppet and valve housing bore. Polish sealing surfaces with fine emery cloth. Make certain orifice is open.</p>

TROUBLE	PROBABLE CAUSE	CORRECTIVE ACTION
	<p>3. System pressure drops in excess of 100 psi (690 kPa) during clutch application and is slow recovering.</p> <p>Continued operation in this manner may cause scuffing of clutch discs against brake assembly and eventual clutch failure.</p> <p>4. System pressure remains low and will not respond to pressure adjustment.</p> <p>Normally the relief pressure adjustment is quite sensitive and rises rapidly with very little movement of the adjusting screw.</p>	<p>3a. See corrective action for K1a, b, and K2b, c.</p> <p>3b. See corrective action for E7a, b.</p> <p>4a. See corrective action for K1d and K2b, c.</p> <p>4b. Control cables are mis-adjusted causing constant leakage from directional control cartridge or brake cartridge. Adjust cables as required.</p> <p>4c. Pump worn, not able to deliver flow at higher pressure. See corrective action for D1, 2, 3, 4 and 5.</p>

WINCH REMOVAL AND INSTALLATION

Before starting any repair procedures, be sure to thoroughly clean the parts to be removed and adjacent areas on the tractor to avoid entry of dirt into the winch. Do not leave any ports or access openings exposed to the weather. Seal or cap the openings to prevent entry of dust, moisture or other foreign material. Cap or plug all exposed hydraulic ports and fittings.

During disassembly, care should be taken not to damage gaskets, shims, seals and o-rings that are to be reused. Replace any such parts that are damaged or otherwise defective. Certain o-rings and seals specified in the replacement instructions must not be reused. In general, seals and o-rings that work under operating hydraulic pressures, or that require extensive disassembly to replace, should be replaced with new parts at time of reassembly.

During assembly, use a suitable thread sealing compound on all capscrews which penetrate the winch case. Take care to prevent excess sealing compound from entering the winch case.

Maintain strict cleanliness during rebuild to prevent entry of dirt or moisture into winch case. Hydraulic components should be rebuilt under the cleanest possible conditions.

WINCH REMOVAL

⚠ WARNING ⚠

Discharge accumulator oil supply before removing any hydraulic lines or servicing winch. Personal injury may result from sudden release of oil under pressure. To discharge the accumulator, stop engine, slowly cycle Power Shift control handle into full Reel-In position then full Reel-out position, a minimum of five (5) times.

Place tractor and winch in level position and drain oil from winch into a suitable container. Install drain plug securely after oil has been drained.

CONTROL CABLE REMOVAL

Remove the eight-½ in. capscrews which secure the right hand cover plate to the winch. Remove the cover plate and locate the control valve and cables.

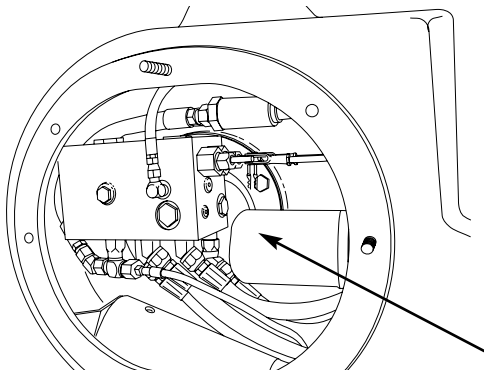

Carefully remove the hitch pins and clevis pins which connect the control cables to the control valve spools.

Remove the fasteners which secure the control stand to the tractor console. Lift the control stand up clear of the console to gain access to the control cables.

Power Shift Cables

Remove the six through-bolts from the control stand and separate the two cable support housing halves. Move the control lever slightly to expose the wrench flats on the plungers.

⚠ CAUTION ⚠

ALWAYS hold the plunger with a wrench when removing or tightening the sliding lock screw on the cable. Applying torque directly to the controller housing will damage the controller.

While holding the plunger with one wrench, remove the sliding lock screw from the plunger and remove the cables from the controller.

Secure the control cables to the winch to avoid damage during winch removal.

Support the winch with a suitable hoist and remove nuts and capscrews securing the winch to the tractor adapters.

⚠ WARNING ⚠

Winch weighs approximately 2,100 lbs (953 kg) without oil, cable and tractor adapters. Make certain lifting equipment has adequate capacity.

Move winch away from tractor cautiously to avoid damaging the PTO pilot and shaft. Cover PTO opening in rear of tractor to prevent entry of dirt or moisture.

WINCH INSTALLATION

Remove dirt, paint and rust from mounting surfaces of winch and tractor adapters.

Coat splines of PTO shaft and couplings (if equipped) with general purpose grease. Lubricate and install o-ring(s) on to winch PTO pilot (if equipped).

Remove winch top cover to gain access to bevel gears.

Carefully install winch on tractor while guiding winch PTO pilot into tractor and rotating bevel gears to align PTO shaft splines.

Install and tighten all fasteners to recommended torque.

Install winch top access cover plate.

Fill winch to proper level with recommended oil.

Route control cables to the control stand in such a manner to avoid chaffing and binding.

CONTROL CABLE INSTALLATION AND ADJUSTMENT

Power Shift Cables

Remove the six through-bolts from the control stand and separate the two cable support housing halves. Hold the control stand in your left hand with the mounting bolts at 6, 9 and 12 o'clock positions. Moving the lever up and down from the 12 to 6 o'clock positions should actuate only the bottom plunger; nearest the 5 o'clock position. Mark this plunger as the "Clutch" control plunger.

Moving the lever from the center toward the 9 o'clock position should move only the top plunger; nearest the 11 o'clock position. Mark this plunger as the "Brake" control plunger.

Install the sliding lock screw over the cable core with the treaded end out. Apply two drops of Loctite 242 or equivalent to the cable core threads and install the threaded bushing onto the cable core until it is level with the end of the cable core.

Install the "Brake" cable, which is installed in the outermost position on the RH side of the winch, to the "Brake" plunger. Install the "Clutch" cable, which is installed in the innermost position on the RH side of the winch, to the "Clutch" plunger.

Move the lever slightly to expose the wrench flats on the plunger.

CAUTION

ALWAYS hold the plunger with a wrench when removing or tightening the sliding lock screw on the cable. Applying torque directly to the controller housing will damage the controller.

While holding the plunger with one wrench, tighten the sliding lock screw to 50 lb•ft (68 N•m).

Install the cable support housings onto the controller and guide the groove of the cable housings into the saddle of the cable clamps. Install the six through-bolts and evenly tighten to achieve 25 lb•ft (34 N•m) torque.

WARNING

DO NOT move the cable adjusters to install the cables. The control cables have been preset at the factory to the proper adjustment. Proper adjustment of the cables is critical to safe and proper winch operation.

If the power shift cable adjusters have been moved, check the cable adjustment by first installing the control cables to the control stand, as described above. Place the power shift control lever in the center, "BRAKE-ON" position. Install the clevis pins into the cable yokes / control valve spools, and secure with hitch pins. The clevis pins should slip easily into the bores without any binding. The control valve spools are spring-centered to neutral. If there is any noticeable binding, turn the cable adjusters in or out until you obtain a "free pin" condition.

WARNING

Fully install hitch pins into clevis pins so that the hitch pins hang from the large end loop. DO NOT leave hitch pins installed at mid-point. Partially engaged hitch pins may become disconnected from clevis pins allowing clevis pins to drop out of clevis/valve spool which may cause loss of winch control which may result in property damage, injury or death.

With the cover removed, check the hydraulic main relief pressure as outlined in the "Control Valve Service" section of this manual. Install the winch cover plate and tighten the fasteners to 75 lb•ft (102 N•m) torque.

WELDING PROCEDURE

The following specifications apply to welding ductile iron to ductile iron or steel to ductile iron when attaching arches, fairleads, or guarding to the winch case.

Preparation:

Attachments should be chamfered to ensure adequate penetration. Weld joints must be free of rust, scale, slag, sand, dirt, grease, oil, paint or moisture. Entire weldment should be not less than 65°F (18°C).

Procedure:

Use multi-pass welding technique (stringer bead) and follow electrode manufacturers recommendation for current, voltage, polarity and speed.

Materials:

Flux coated "stick" electrode

Composition – Ni	43.75%	Mn	11.00%
C	1.50%	Fe	43.75%

Mechanical properties - tensile strength	65,000 – 84,000 psi (448,000 – 579,000 kPa)
yield strength	45,000 – 65,000 psi (310,000 – 448, 000 kPa)
elongation	15-25%

Flux cored wire

Composition - Ni	50.00%	Fe	44.00%
C	1.00%	Si	0.60%
Mn	4.20%		

Mechanical properties - tensile strength	64,000 – 74,000 psi (441,000 – 510,230 kPa)
yield strength	43,000 – 50,000 psi (297,000 – 345,000 kPa)
elongation	15-25%

WIRE ROPE INSTALLATION

All winches are rated at bare drum line pull. As the cable drum fills, the line pull will decrease (loss of leverage) as the line speed increases (larger circumference). Therefore, install the minimum length of cable possible for your application so that the winch will operate on lower layers (smaller diameter) and deliver the maximum line pull.

Using larger cable will not always increase strength, as the larger cable may be more prone to bending fatigue failure than smaller wire rope. Consult your wire rope supplier for his recommendations for the wire rope and other rigging which best suits your application.

INSTALLATION OF SPIRAL FERRULES

Re-usable, field-installed spiral ferrules are not supplied with all Carco winches. These ferrules are for use with standard six-strand, IWRC (Independent Wire Rope Core) type wire rope. Refer to ferrule selection chart in the "Specifications" section of this manual.

⚠ **WARNING** ⚠

Winch cable anchors (ferrules and ferrule pocket) are **NOT** designed to hold rated loads. Winch loads applied directly to the cable anchor may cause the cable to pull free and result in the sudden loss of load control and cause property damage, personal injury or death. **A minimum of 5 wraps of cable must be left on the drum barrel to achieve rated load.** Do not use knots to secure or attach winch cable. We suggest that the last 5 wraps of cable be ainted bright red to serve as a visual reminder.

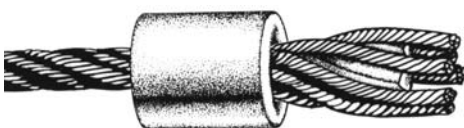

Step One

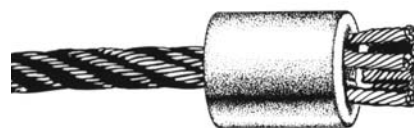

Step Two

Insert cable through the small opening of the ferrule. Spread strands and lay them in individual grooves in spiral wedges.

Tap wedges and cable into the ferrule leaving approximately 3/8 in. (10 mm) extending from the top. The first load will seat cable and wedges securely in the ferrule.

BEVEL PINION AND HYDRAULIC PUMP SERVICE

The bevel pinion, bevel gears and hydraulic pump are turning whenever the tractor PTO shaft is turning. The bevel pinion transmits torque from the PTO shaft to the bevel gears, clutch shaft and winch gear train. Proper adjustment of bevel pinion/bevel gear back-lash and tooth contact pattern is essential for quiet operation and long component life.

The bevel pinion and hydraulic pump share common carrier housing. The carrier is mounted in the front face of the winch case and will be located in the upper bore for standard PTO winches and in the lower case bore of low PTO winches.

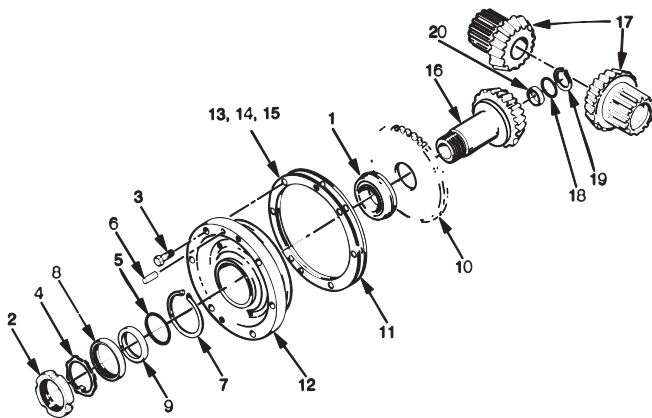
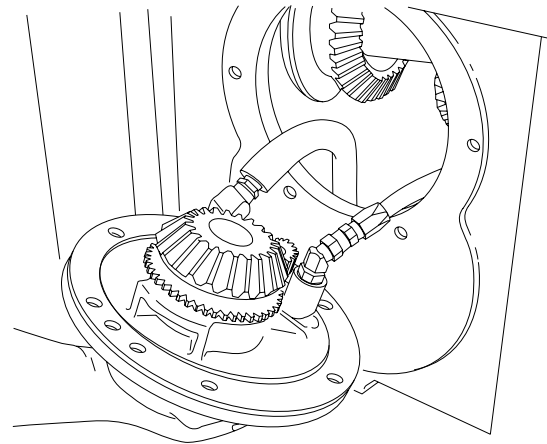

ITEM	DESCRIPTION	QTY
1	Bearing Assembly	1
2	Bearing Locknut	1
3	Capscrew, Hex Head	6
4	Lockwasher	1
5	O-Ring	1
6	Dowel Pin	1
7	Retaining Ring	1
8	Oil Seal	1
9	Seal Spacer	1
10	Pump Drive Pinion	1
11	Shim Gasket	1
12	Carrier	1
13, 14, 15	Shims	2-AR
16	Bevel Pinion	1
17	Bevel Gear	2
18	O-Ring	1
19	Retaining Ring	1
20	Plug, Bevel Pinion	1

BEVEL PINION CARRIER REMOVAL

Drain oil from winch and remove the winch from the tractor as described in "Winch Removal and Installation" section of this manual. Leave the winch mounting adapter plates attached to the tractor where applicable.

Remove the ½ in. capscrews which secure the bevel gear inspection plate to the top of the winch case. Remove the inspection plate. Remove the pump suction tube and pressure hoses from the pump. Remove the capscrews (3) securing the carrier assembly to the winch case. Using two of the capscrews as "jackscrews", remove the carrier assembly. Retain the shim set (13, 14, 15) for reassembly.

BEVEL PINION REMOVAL

Bend the tang of the lockwasher (4) away from the locknut (2) and remove the locknut (2) and lockwasher (4).

Support the carrier assembly in a suitable press. Place support blocks toward the outer diameter of the carrier. From the locknut end, press out the bevel pinion (16).

Remove the bearing cone set spacer from the bevel pinion. Position the bevel pinion assembly in a suitable press with support blocks under the pump drive pinion (10) as close to the bevel pinion gear as possible. Press the bevel pinion (16) free of the bearing cone and pump drive pinion.

Support the carrier in a vice and remove the oil seal (8), oil seal spacer (9) and o-ring (5).

Remove the oil seal retaining ring (7) and outer bearing cone. Remove the bearing cups, bearing cup retaining ring and the set spacer from the carrier.

Remove the retaining ring (19) and plug (20) from the end of the bevel pinion. Remove the o-ring (18) from the groove in the gear.

Thoroughly clean and inspect all parts at this time. All components of the bearing assembly are a matched set with the bearing adjustment controlled by the inner and outer set spacers. If the bearing cone or cup is worn or damaged, the entire bearing assembly (1) must be replaced.

BEVEL PINION ASSEMBLY

Lubricate and install o-ring (18) into the groove in the bore of the bevel pinion (16). Install plug (20) with chamfered edge toward the o-ring. Secure the plug in the pinion with the retaining ring (19).

i NOTE: *On bevel pinions equipped with a threaded plug, apply Loc-tite 242 or equivalent to socket head plug and tighten securely.*

Clean and dry bore of pump drive pinion (10) and mating surface on bevel pinion (16) with Loc-tite primer or equivalent.

Apply Loc-tite 601 or equivalent to pump drive pinion bore and mating bevel pinion surface. Press pump drive pinion onto bevel pinion and seat securely against bevel pinion shoulder. Allow Loc-tite to harden.

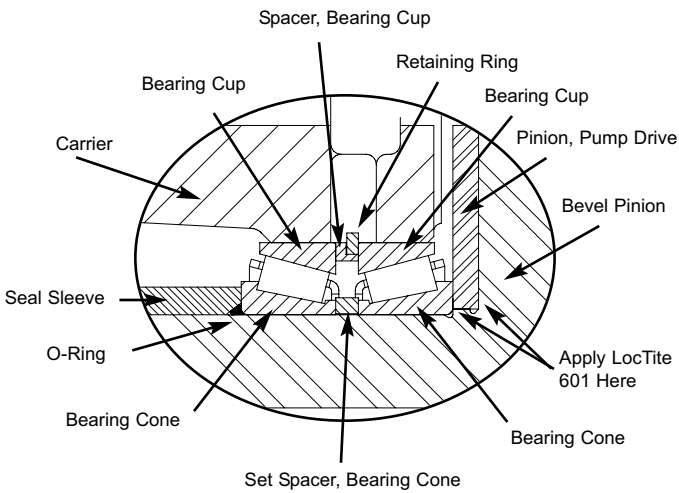

Press one bearing cone of the bearing assembly (1) on to the bevel pinion and seat securely against the pump drive pinion. Install bearing cone set spacer on to the bevel pinion.

Install the bearing cup retaining ring into the groove in the carrier bore.

Place the carrier assembly onto bench with the pump side facing up. Install one bearing cup of bearing set (1) and seat against the retaining ring.

Turn the carrier over so that the pump side faces down. Install the bearing cup spacer with the shoulder inside of the retaining ring. Install the remaining bearing cup and seat firmly against the bearing cup spacer and retaining ring.

Place the carrier over the bevel pinion so that the pump side bearing cup seats on the bearing cone.

Press the remaining bearing cone securely onto the bevel pinion, seating into the bearing cup.

Lubricate and install O-Ring (5) onto the bevel pinion against the bearing cone. Install seal spacer (9) over the bevel pinion with internal tapered edge toward the bearing cone and O-Ring.

Install the oil seal retaining ring (7) into the carrier bore groove. Apply non-hardening sealant to the outside surface of the oil seal (8) and install the oil seal firmly against the retaining ring (7).

Install the bearing lockwasher (4) and locknut (2) onto the bevel pinion. Tighten the locknut to 150 lb•ft (203 N•m) torque and bend tang of lockwasher (4) into slot of locknut.

BEVEL PINION CARRIER INSTALLATION

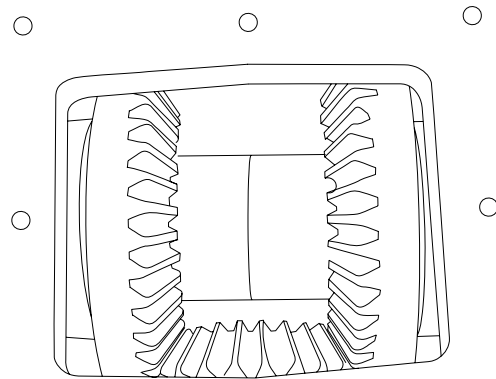

Apply gear tooth marking compound to bevel pinion and install carrier assembly into winch case using the original shim set. Replace gasket as required. Tighten capscrews to 75 lb•ft (102 N•m) torque.

Rotate bevel pinion in same direction as PTO shaft rotation and check bevel pinion/gear tooth contact pattern.

See typical contact patterns, next page.

Remove carrier assembly to add or remove shims to obtain the correct tooth contact pattern illustrated below.

Refer to Clutch Shaft Service for bevel gear backlash adjustment procedure.

Upon final installation of carrier assembly, apply non-hardening thread sealant to capscrews and tighten to 75 lb•ft (102 N•m) torque.

Refill winch to proper level with recommended lubricant.

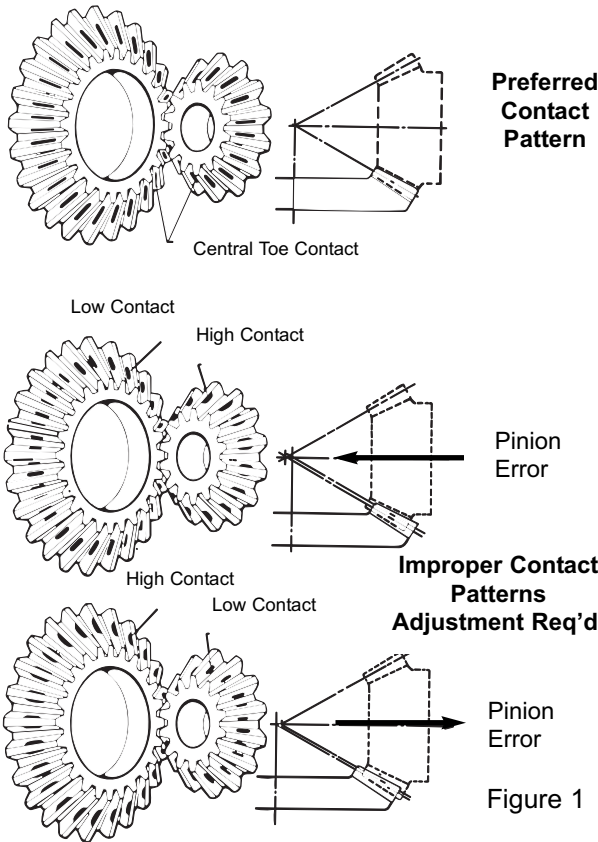

3. Attach pump line to the gauge side of the gate valve or flow meter. Direct the open end of the gate valve/flow meter back into the winch case.
4. With gate valve/flow meter fully open, operate engine at 650-700 RPM and measure oil flow by directing oil into a container for 15 seconds.
5. Gradually close gate valve/flow meter until you have applied 350 psi (2413 kPa) load to the pump. Again record the flow for 15 seconds.

⚠ CAUTION ⚠

Do not fully close gate valve/flow meter as pump or hose damage will result.

The minimum acceptable pump flow is 2 gpm (US) (7.6 lpm) at 650-700 RPM PTO speed and 350 psi (2413 kPa). Two quarts per 15 seconds equals 2 gm.

If pump flow is below minimum:

1. Check/verify PTO speed and accuracy of tachometer.
2. Check suction strainer for restriction.
3. Check suction hose for cracks or poor connection.
4. Pump is worn and requires replacement.

HYDRAULIC PUMP SERVICE

The hydraulic pump supplies oil to the control valve to recharge the accumulator, apply clutches, release the brake, and lubricate critical components. Maintaining adequate oil flow is critical to reliable winch operation.

Pump flow should be tested with an accurate, commercially available flow meter. If a flow meter is not available, a serviceable flow meter may be fabricated from a gate valve, tee and gauge as listed below.

- Gate valve – ½ NPT port minimum, 1,000 psi (6,895 kPa) rating, minimum.
- ½ NPT schedule 80 pipe tee with a –8JIC hose adapter on one run
- Accurate 0-600 psi (0-4,137 kPa) gauge

Attach ½ NPT run end of tee to gate valve with –8JIC adapter on opposite run.

Install gauge to branch of tee.

TEST PROCEDURE

1. Operate tractor and winch long enough to bring oil up to operating temperature. Stop engine.
2. Remove access cover on right hand side of winch and locate pump port on control valve labeled “P”. Remove –8JIC pump line from the tee in the pump port of the control valve.

HYDRAULIC PUMP REMOVAL

Remove the ½ in. capscrews which secure the bevel gear inspection cover to the top of the winch case. Remove the inspection plate. Remove the pump suction tube and pressure hose from the pump. In most applications, the pump may be removed from the bevel pinion carrier through the top of the winch case. If this is not practical in your application, then remove the bevel pinion carrier from the winch case as described in the “Bevel Pinion Carrier Service” section of this manual.

Remove the four capscrews and lockwashers (5, 6, 7) securing the pump to the bevel pinion carrier.

Remove the pump assembly and wear plate (1) from the bevel pinion carrier.

Thoroughly clean and inspect all pump components at this time. If there is any sign of damage or wear which may reduce pump performance, the entire pump assembly must be replaced.

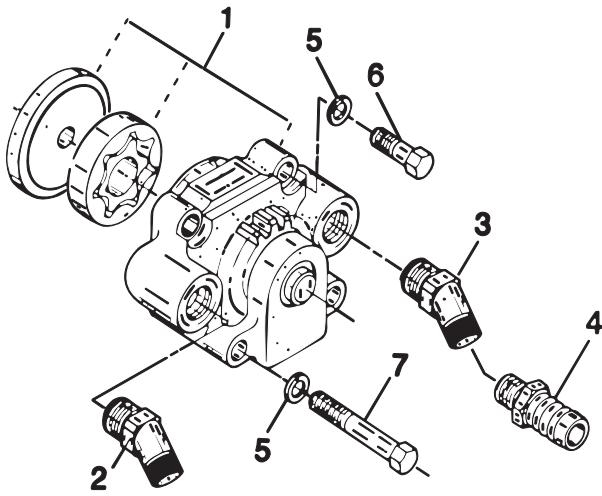

PUMP INSTALLATION

Lubricate entire pump assembly with recommended oil.

Coat the capscrew threads with Loc-tite 242 or equivalent and evenly tighten to 100-110 lb•in by 25•lb in (11.3-12.4 N•m by 2.8 N•m) increments in a cross pattern.

When properly installed, there will be a slight gap, .005-.040 in. (.13-1.02 mm) between the mounting ears of the pump housing and the bevel pinion carrier. This condition insures that the pump housing is clamped and sealing against the wear plate.

Apply non-hardening thread sealant to the pipe threads and install the suction (3, 4) and pressure (2) hose adapters as follows:

- A. For counter-clockwise (ccw) bevel pinion rotation, the most common, install the pressure adapter into "A" port.
- B. For clockwise (cw) bevel pinion rotation, install the pressure adapter into "B" port.

i **NOTE:** Determine direction of bevel pinion rotation when viewed from rear of winch looking forward toward the tractor.

If Bevel Pinion Carrier was Removed

When installing the bevel pinion carrier assembly into the winch case, make certain the hose connections are tight, hose routed away from gears, etc. and the suction hose is secured to the barbed suction fitting with a heavy duty hose clamp (where applicable).

Install bevel pinion carrier as described in the "Bevel Pinion Carrier Installation" section of this manual.

Install suction tube assembly securely to the pump suction port.

Install the pressure hose securely to the pump pressure port and make certain the hose is routed away from the bevel gears and clutch housing to avoid chaffing and failure.

CLUTCH SHAFT SERVICE

DESCRIPTION

The clutch shaft assembly contains or supports the two bevel gears, the Reel-In and Reel-out clutches, the brake hub and the first reduction pinion gear.

OPERATION

The bevel gears are continuously driven by the bevel pinion and, when no clutches are applied, spin freely on needle roller bearings. The bevel gears are splined to the friction discs of the clutches. The steel clutch discs are splined to the clutch housing and the clutch housing is splined to the clutch shaft.

When a clutch is applied, the clutch piston compresses the friction and steel discs tight enough to transmit power from the bevel gears to the clutch shaft. The direction the clutch shaft turns depends on which clutch is applied.

The clutch shaft transmits power to the winch reduction gears through the small pinion gear splined to the left hand end of the shaft.

Splined to the right hand end of the clutch shaft is the brake hub which is splined to the friction discs of a powerful, load holding multi-disc oil brake. The friction discs are alternately stacked between steel discs which are splined to the brake housing which is anchored to the winch case.

The brake is spring applied and hydraulically released. The clutch shaft and the entire winch gear train is held firm by the brake until hydraulic oil pressure overcomes the spring force to relieve the compression of the discs. When released, the clutch shaft and brake hub can turn as the brake friction discs slip freely between the brake steel discs.

The bevel gears and center portion of the clutch shaft are supported by two large ball bearings while the ends of the shaft are supported by two tapered roller bearings.

The clutches are supplied with application oil pressure from passages drilled through the center of the shaft. Clutch application oil travels from the control valve to the clutch shaft bearing carriers where the oil passes through a rotary seal shaft installed in the drilled passages at the ends of the shaft.

REMOVAL

Drain oil and remove winch from tractor as described in the "Winch Removal and Installation" section of this manual. Remove only the winch, leaving the mounting blocks attached to the tractor; where applicable.

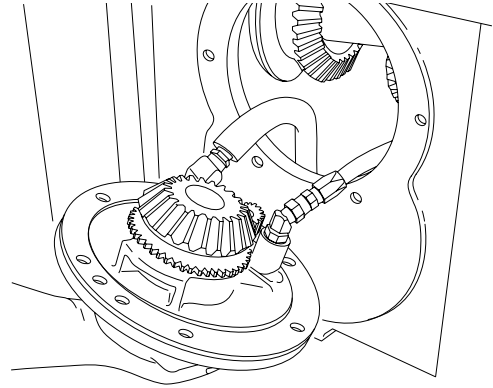

Remove the six capscrews then remove the bevel pinion and pump carrier from the front of the winch. Retain the shim set for reassembly. Refer to "Bevel Pinion and Pump Carrier Service" for additional information.

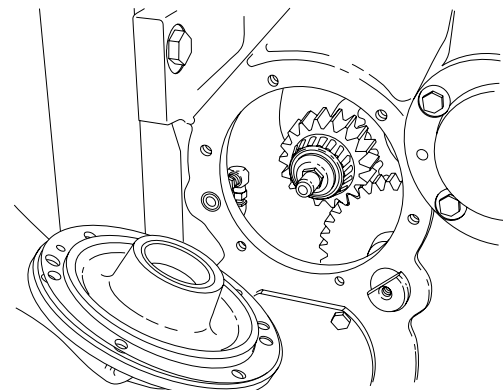

Remove the six capscrews (10) then remove the left hand clutch shaft bearing carrier (35). Retain the shim set for reassembly. Inspect the bearing cup (4) in the bearing carrier and replace as required.

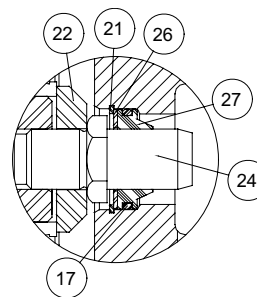

ITEM	DESCRIPTION	QTY.
17	O-Ring	2
21	Retaining Ring	2
22	Bearing Retainer	2
24	Rotary Seal Shaft	2
26	Back-Up Washer	2
27	Rotary Seal	2

Remove the retaining ring (21) from the bore of the bearing carrier, then remove the rotary seal assembly (17, 26, 27).

Remove the six 1/2 in. capscrews securing the brake assembly to the winch case. DO NOT remove the two 3/8 in. capscrews securing the outer bearing carrier cover to the brake housing at this time. Refer to "Brake Assembly Service" for additional information.

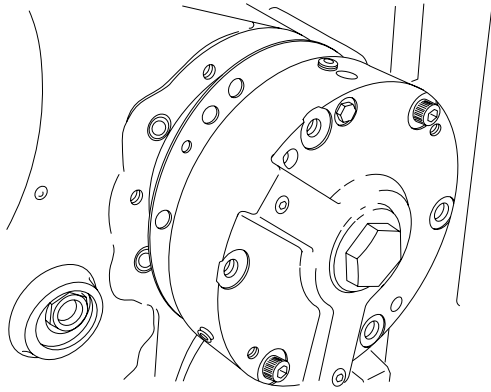

Using a wood block, bump the end of the clutch shaft at the left hand side of the winch to unseat the brake assembly. Remove the brake assembly. Retain the shim set for reassembly.

Grasp the brake hub and pull the clutch shaft assembly out of the winch through the brake opening.

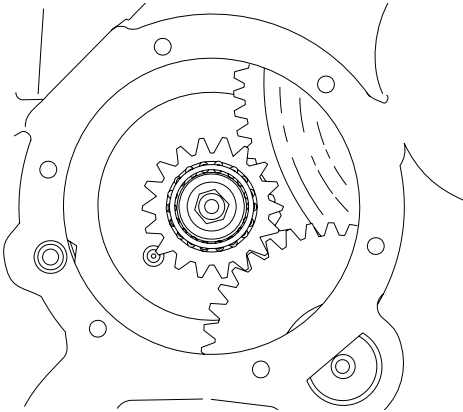

The clutch shaft pinion gear (28) will not clear the first reduction gear on the idler shaft. One of the following methods may be used to remove the clutch shaft assembly.

1. Refer to "Idler Shaft Service" and remove the first reduction gear and second reduction pinion assembly.

or

2. Remove the rotary seal shaft (24) and bearing retainer (22) from the left hand side of the clutch shaft. With a gear puller, remove the bearing cone (5) and pinion gear (28).

⚠ CAUTION ⚠

DO NOT use an impact wrench to remove or install the rotary seal shaft (24). This part has been heat treated to provide long service life with the rotary seal and may be damaged by impact or over tightening. **Use hand wrenches only.**

To facilitate removal of the clutch shaft assembly, have an assistant place a 3 ft. (1 m) length of 1 in. (25 mm) I.D. pipe over end of the rotary seal shaft and lift slightly as you both move the clutch shaft assembly out through the

brake opening. Move the clutch shaft assembly out of the winch case far enough to place a lifting sling between the bevel gears.

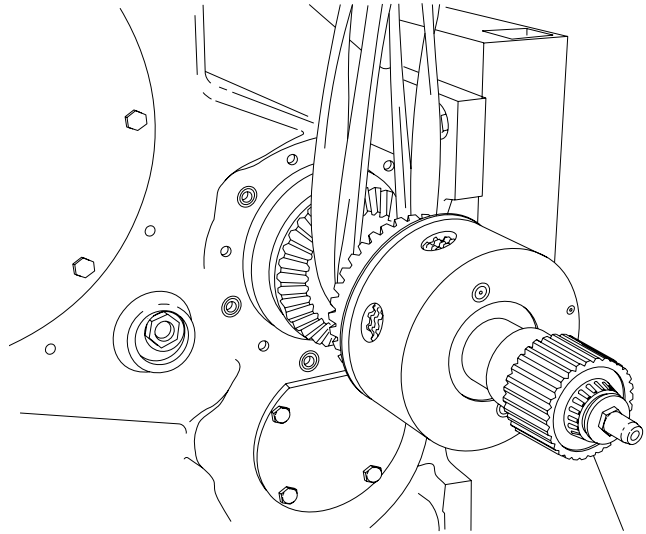

Complete clutch shaft removal from winch case and place shaft assembly on clean work surface.

During disassembly, keep all components in the order in which they were removed.

Remove the rotary seal shafts (24) and bearing retainers (22) from each end of the clutch shaft.

With a gear puller, remove the pinion gear (28) and bearing cone (5) from the clutch shaft (if not already removed). Remove the brake hub (29) and bearing cone (9) from the clutch shaft.

Remove and discard o-rings (19) and back-up rings (23) from the clutch shaft.

Slide each clutch assembly off of the shaft. Refer to "Clutch Assembly Service" for additional information.

Remove the bevel gear thrust bearing assembly (7,13,25) from the shaft.

Remove the bevel gear and bearing carrier assemblies (3,31) from the shaft. Inspect bearings (3) and press off gears if replacement is necessary. Note correct position of bearing (3) and carrier (31) retaining rings when installed on the bevel gears. The bearings have been "staked" into the carrier. If bearing replacement is necessary, use a press to remove and install the bearings. Use a center punch to "restake" the bearing carriers onto the bearings.

Remove the bevel gear needle bearings (8) and inner races (6) from the shaft.

Remove the bevel gear spacers (30) and shim set (33) from the shaft. Be sure to retain the shims for reassembly.

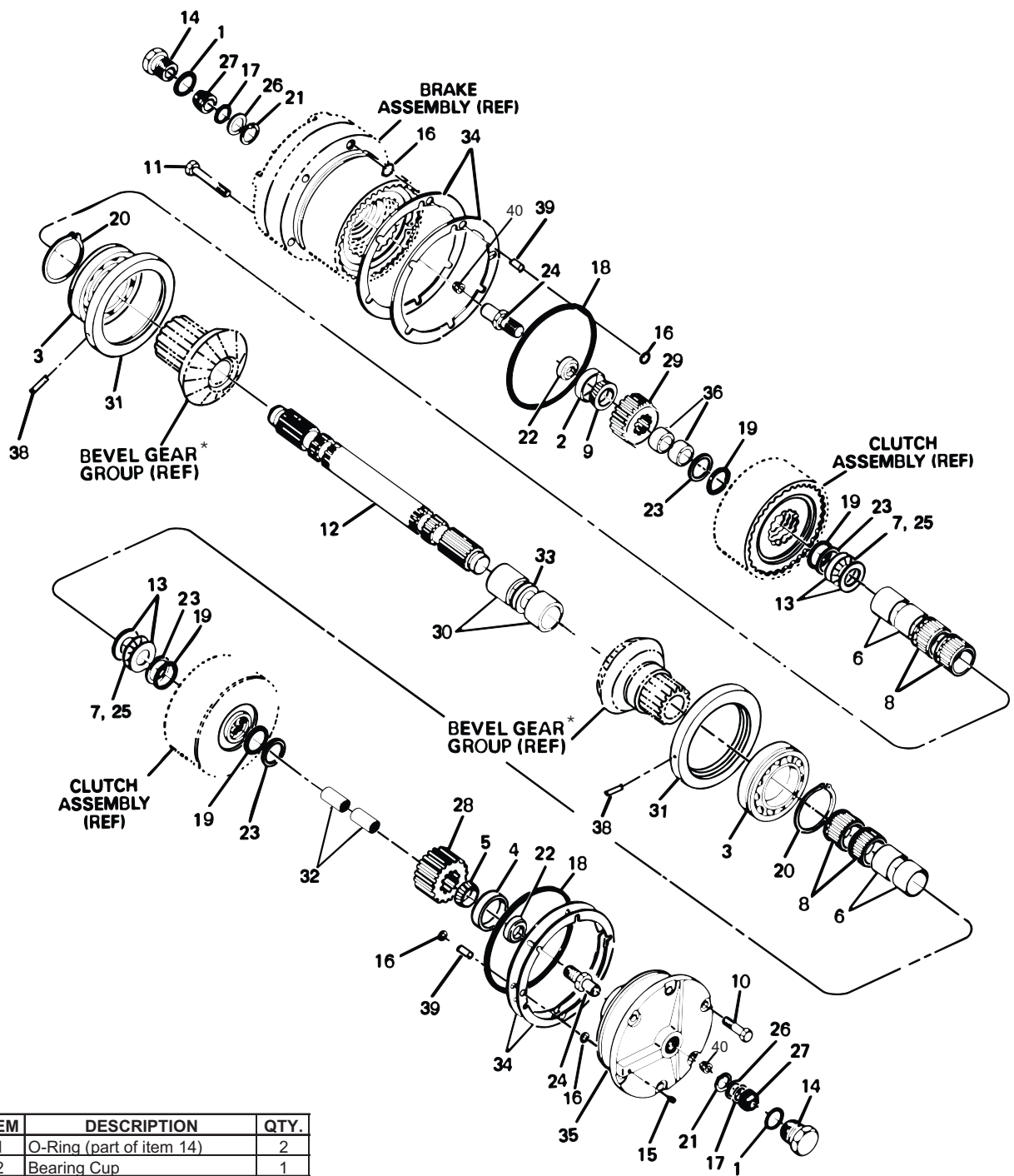

ITEM	DESCRIPTION	QTY.
1	O-Ring (part of item 14)	2
2	Bearing Cup	1
3	Ball Bearing - STD PTO	2
4	Bearing Cup	1
5	Bearing Cone	1
6	Needle Bearing - Inner Race	4
7	Thrust Bearing	2
8	Needle Bearing - Inner Race	4
9	Bearing Cone	1
10	Capscrew, Hex Head	6
11	Capscrew, Hex Head	6
12	Clutch Shaft	1
13	Thrust Bearing Race	2
14	Plug (contains item 1)	2
15	Plug (contains item 1)	1
16	O-Ring	8
17	O-Ring	2
18	O-Ring	2
19	O-Ring	4
20	Retaining Ring	2
21	Retaining Ring	2
22	Bearing Retainer	2
23	Back-up Ring	4
24	Rotary Seal Shaft	2

ITEM	DESCRIPTION	QTY.
25	Thrust Bearing, Shoulder Spacer	2
26	Back-up Washer	2
27	Rotary Seal	2
28	Pinion Gear	1
29	Brake Hub	1
30	Bevel Gear Spacer	2
31	Bearing Carrier	2
32	Pinion Spacer	1
33	Shim Set	1
34	Shims (.005, .007, .020 in.)	AR
35	Clutch Shaft Bearing Carrier	1
36	Brake Hub Spacer	1
37	Spring, 50B/70A only - Not shown, located under item 14	1
38	Roll Pin - Ref. SB93	2
39	Sleeve - 50B/70A only	4

ASSEMBLY

Thoroughly clean and carefully inspect all components prior to assembly. If a component's condition is questionable – replace it!

Due to machining tolerances, installation of any new components listed below will alter the original shim pack used between the bevel gears to establish the required backlash between the bevel gears and bevel pinion.

Measurements of components must be taken and used to establish a new shim pack thickness to maintain the required .004-.012 in. (.1-.31 mm) backlash.

Use the following formula and list of components to be measured to establish the new shim pack.

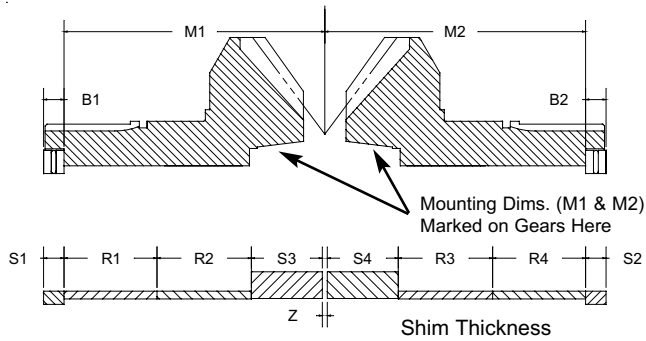

Due to machine tolerances, the thickness of the shim pack must be determined individually for each winch. The same parts which have been used for measuring must be used together.

ITEM	QTY	DESCRIPTION
B1, B2	2	Thrust Bearing Assembly (Thrust bearing (7) and 2 thrust bearing races (13)).
S1, S2	2	Thrust Bearing Shoulder Spacer (25)
S3, S4	2	Bevel Gear Spacer (30)
R1 thru R4	4	Needle Bearing Inner Race (6)
M1, M2	2	Bevel Gear

Shim Pack Thickness:

$$Z = B1 + B2 + M1 + M2 - S1 - S2 - S3 - S4 - R1 - R2 - R3 - R4$$

The basic shim pack supplied through Service Parts is .120 in. (3.05 mm) thick.

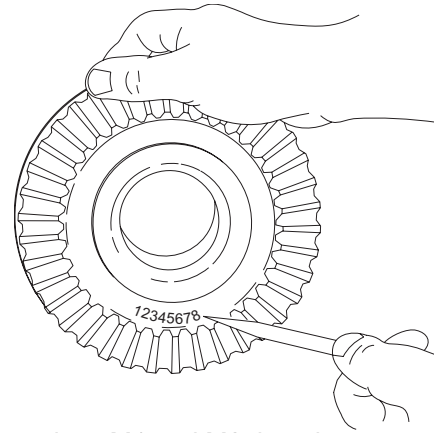

Record dimensions M1 and M2, bevel gear mounting distance. The mounting distance has been etched into the inside surface of the bevel gears.

Measure and record dimension B1 and B2, thrust bearing assembly. Each thrust bearing assembly includes: one thrust bearing (7) and two thrust bearing races (13).

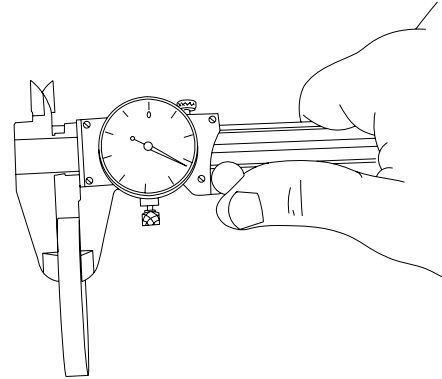

Measure and record dimension S1 and S2, thrust bearing spacer thickness (25) and S3 and S4 bevel gear spacer thickness (30).

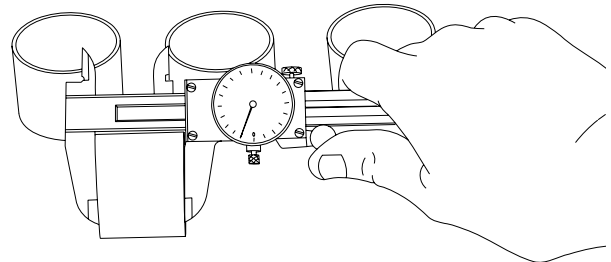

Measure and record dimension R1, R2, R3 and R4 bevel gear bearing inner race (6) thickness.

The shim pack thickness, Z, to use in re-assembly of the clutch shaft is the total mounting distance of the bevel gears M1 and M2 plus the total thickness of the thrust bearing assemblies B1 and B2 less the total thickness of the bevel gear spacers S3 and S4, inner bearing races R1, R2, R3, R4 and thrust bearing spacers S1 and S2.

Begin the clutch shaft assembly by first installing the brake side components. Install the shim pack, Z (previously determined by the component measurement) onto the clutch shaft between the bevel gear spacers (30).

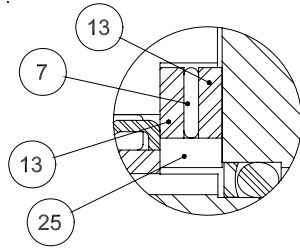

ITEM	DESCRIPTION	QTY.
7	Thrust Bearing	2
13	Thrust Bearing Race	4
25	Thrust Bearing Spacer	2

Install two inner bearing races (6) onto the brake side of the clutch shaft.

Install a bevel gear/bearing carrier assembly onto the clutch shaft, positioning the bevel gear over the needle bearing races (6). Lubricate and install two needle bearings (8) between the bevel gear and the bearing races.

Lubricate and assemble the thrust bearing (7) between two thrust bearing races (13) and place over the splined thrust bearing spacer (25).

Install the thrust bearing assembly (7,13 25) onto the clutch shaft while fully seating the assembly against the bevel gear.

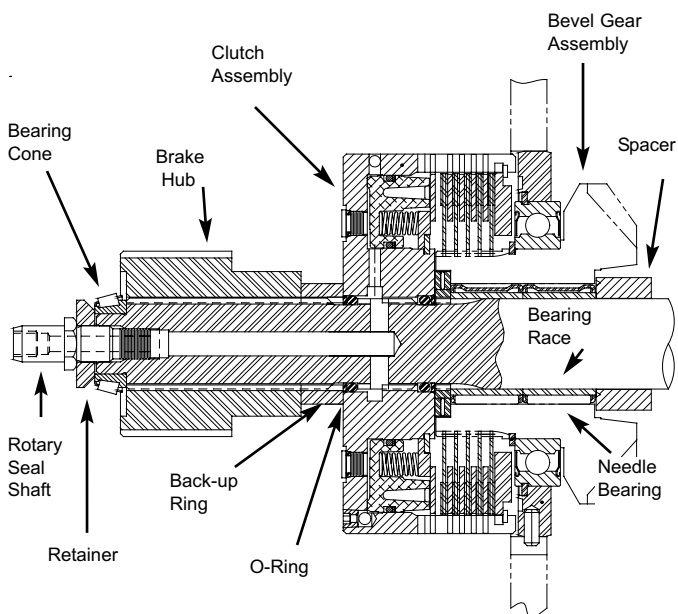

Lubricate and install an o-ring (19) and back-up ring (23) into the inner groove of the shaft with the back-up ring placed next to the splined thrust bearing spacer (25).

i NOTE: The concave (cupped) side of the back-up ring (23) must always face the o-ring (19).

Install a clutch assembly onto the shaft aligning the splines of the clutch friction discs with the splines of the bevel gear. Seat the clutch over the o-ring and back-up ring installed on the clutch shaft.

Lubricate and install an o-ring (19) into the outer groove of the clutch shaft and seat into the clutch housing. Install the back-up ring (23) next to the o-ring. Install the brake hub spacer (36) onto the clutch shaft next to the clutch housing. The spacer should hold the o-ring and back-up ring into the clutch housing.

Install the brake hub (29) onto the clutch shaft with the small end against the spacer (36).

Install bearing cone (9) onto the clutch shaft. Press into position until the bearing cone seats securely against the shoulder of the shaft.

Install rotary seal shaft (24) and retainer (22) onto the clutch shaft. Install the bearing retainer with the small diameter (chamfered) side toward the bearing cone. Apply Loc-tite 271 or equivalent to the threads and pilot shoulder of the shaft and tighten the early design to 40 lb•ft (54 N•m) torque. Tighten the current design to 130 lb•ft (175 N•m) torque.

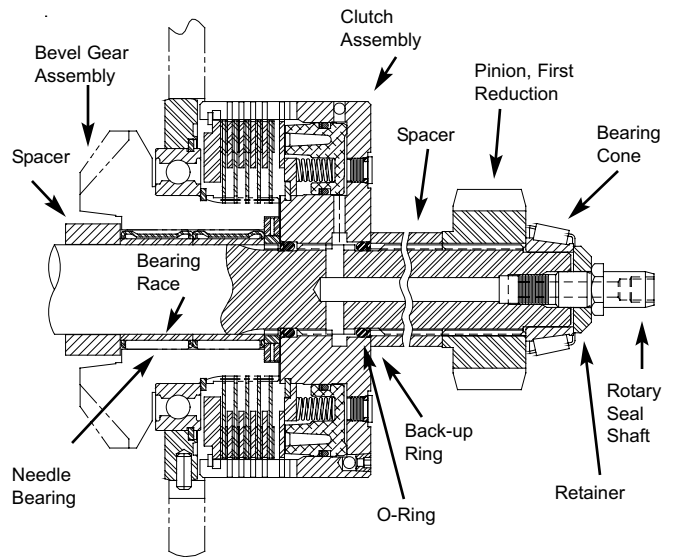

Complete the assembly of the clutch shaft by installing the remaining components on the gear side of the shaft.

Lubricate and install two inner bearing races (6) onto the shaft.

Install the remaining bevel gear assembly over the inner bearing races.

Lubricate and install two needle bearings (8) between the bevel gear and bearing races.

Assemble the remaining thrust bearing, as described earlier, and install it onto the clutch shaft.

Lubricate and install an o-ring (19) and back-up ring (23) into the inner groove of the shaft, with the back-up ring placed next to splined thrust bearing spacer (25).

Install a clutch assembly onto the shaft, aligning the splines of the clutch friction discs with the splines of the bevel gear. Seat the clutch over the o-ring and back-up ring in the inner groove of the shaft.

Lubricate and install an o-ring (19) into the outer groove of the clutch shaft and seat into the clutch housing. Install the back-up ring (23) next to the o-ring.

Install spacer (32) over the clutch shaft, next to the clutch assembly. The spacer will hold the o-ring and back-up ring into the clutch housing.

Install the first reduction pinion gear (28) onto the clutch shaft next to the spacer.

Install bearing cone (5) onto the shaft. Press the bearing cone firmly against the pinion gear (28) until no clearance remains between any of the components of the clutch shaft.

Install the rotary seal shaft (24) and retainer (22) into the end of the clutch shaft. Install the bearing retainer with the large diameter (flat) side toward the bearing cone. Apply Loc-tite 271 or equivalent to the threads and pilot shoulder of the shaft and tighten to 40 lb•ft (54 N•m) torque. Tighten the current design to 130 lb•ft (175 N•m) torque.

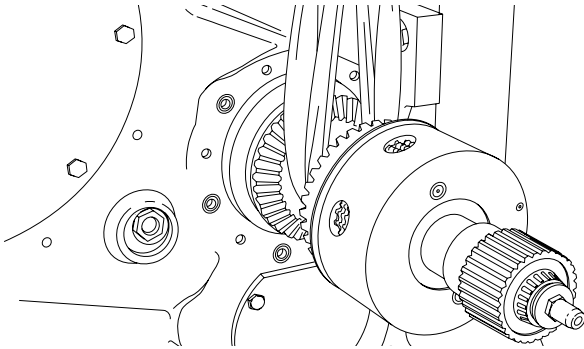

INSTALLATION

Place the lifting sling between the bevel gears and install the clutch shaft assembly into winch case through the brake opening. Carefully slide the assembly into the center of the winch case where the bevel gear bearing carriers (31) are supported by the winch case.

Rollpins (38) are driven into the outside surface of the bevel gear bearing carriers (31). These rollpins must be aligned with grooves machined in the inner case bores.

Lubricate and install three o-rings (16) into grooves of the winch case oil ports on the brake side.

Lubricate and install three (3) more o-rings (16) into grooves of the brake housing oil ports.

Use the shim set (34) removed during disassembly or a new shim set of the same thickness. Position shim set

over the brake housing, aligning oil ports.

Lubricate and install o-ring (18) into the groove around the brake housing.

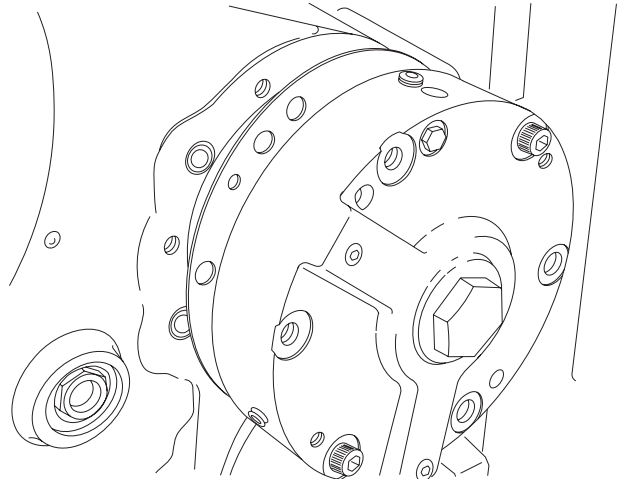

Install the brake housing and shim set into the winch case carefully aligning the oil ports. Make certain that all of the brake friction discs have engaged the brake hub (29) before installing capscrews.

Evenly tighten all capscrews to 75 lb•ft (102 N•m) torque.

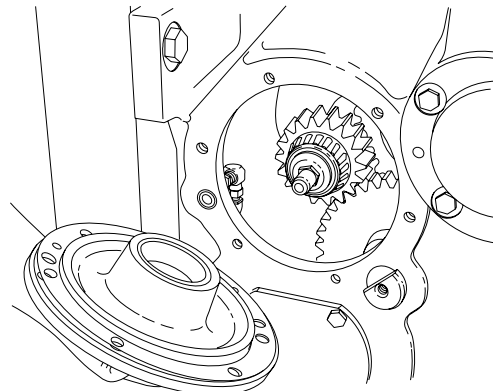

Lubricate and install o-ring (16) into groove of winch case oil port and into groove of bearing carrier (35).

Use the original shim set or a new shim set of the same thickness. Position the shim set over the bearing carrier, aligning the oil port and bolt holes.

Lubricate and install the o-ring (18) around the bearing carrier cover.

Install rotary seal and o-ring (17, 27) into the bore of the cover. Install back-up washer (26) and secure with retaining ring (21).

Install the bearing carrier assembly (35) into the winch case, carefully aligning the oil port in the cover and shim set with the oil port in the winch case.

Coat threads of capscrews (10) with thread sealant (50A/70 only) and tighten to 70 lb ft (102 Nm) torque.

Place a dial indicator at the end of the rotary seal shaft in the left hand bearing carrier cover. (Plugs 14, have been removed)

Move clutch shaft assembly from side to side by tapping rotary seal shaft with a wood block. End play should be .005 - .010 in. (.13 - .25 mm).

Remove left hand bearing carrier cover and add or remove shims (34) as required to obtain correct end play.

Install plug (14) into bearing carrier cover.

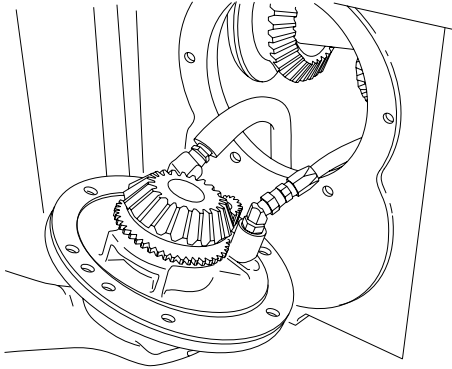

Install bevel pinion and pump carrier assembly into the front of the winch. Use the original shim set and shim gasket, or new shim set and gasket of the same thickness.

Refer to "Bevel Pinion and Pump Carrier Service" for installation instructions and procedure for obtaining correct tooth contact pattern.

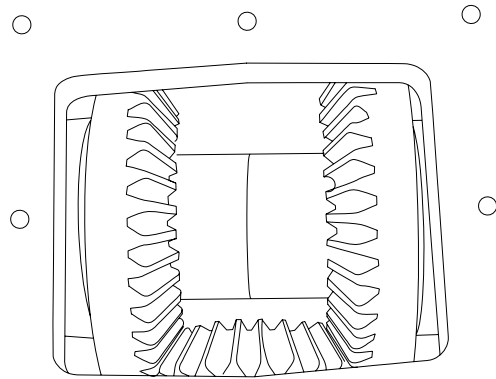

With correct bevel gear tooth contact pattern established, move clutch shaft assembly to the right (brake side). Gently tap wooden wedge between the bevel gear spacers and bevel pinion to move the bevel pinion away from the bevel gears, eliminating any axial bearing assembly clearance.

Place a dial indicator on the right hand bevel gear and check backlash reading of .004 - .012 in. (.10 - .31 mm).

Move the clutch shaft assembly to the left. Place a dial indicator on the left hand bevel gear and check backlash reading of .004 - .012 in. (.10 - .31 mm).

Transfer shims between brake housing and left hand bearing carrier to equalize the bevel gear backlash.

If an equalized bevel gear backlash reading is not obtainable, recheck bevel gear and pinion tooth contact pattern and recheck end play in clutch shaft assembly.

Repeat backlash measurements on left hand and right hand bevel gears until an equalized .004 - .012 in. (.10 - .31 mm) reading is obtained.

Install plugs (14) into brake housing and left hand bearing carrier.

Make certain pump hoses and all capscrews are properly tightened.

Refill winch to proper level with recommended oil.

CLUTCH ASSEMBLY SERVICE

Two identical clutch assemblies are mounted on the clutch shaft: One is used to Reel-In, the other for Reel-out. Each clutch contains five friction discs (12) splined to the bevel gears and four steel discs (13) splined to the clutch housing. The clutch housing is splined to the clutch shaft.

When the operator shifts his control handle to operate the winch, hydraulic pressure is directed through a passage in the clutch shaft to the appropriate clutch housing. The oil pressure then acts on the clutch piston to compress the steel and friction discs thereby locking the bevel gear to the clutch shaft and winch gear train.

When the operator returns the controls to "Brake-on", the clutch application oil will be exhausted through the control valve and through a small check valve installed in the clutch housing. The piston return springs (3) will push the piston away from the clutch discs and permit the bevel gear to turn free of the clutch shaft which is now locked by the spring applied brake.

REMOVAL

Right hand or left hand clutch removal may be accomplished with a winch mounted to the tractor. However, if both clutch assemblies are to be inspected for repair and/or replacement, it is advantageous to remove the

winch from the tractor.

The bevel pinion carrier and pump assembly is removed from the front of the winch and, after removal of the brake assembly, the complete clutch and bevel gear shaft assembly is removed through the brake opening on the right hand side of the winch.

Refer to Clutch Shaft Group, for removal and disassembly of the clutch and bevel gear shaft assembly.

DISASSEMBLY

Remove the pressure plate retaining ring(s) (7).

Remove the pressure plate (10) clutch friction discs (12) and steel discs (13). The clutch pack consists of five friction discs and four steel discs.*

Inspect friction discs for wear and flatness. Original disc thickness is .138-.148 in. (3.5-3.8 mm). Oil groove depth on new discs is .015 in. (.38 mm) minimum. Replace friction discs if the oil groove is .005 in. (.13 mm) or less, disc is not flat, or friction material is worn unevenly.

Inspect steel discs for scoring and warpage. Discs are flat and .093 in. (2.36 mm) thick. Replace steel discs if they are not flat beyond .015 in. (.4 mm), heat discolored, or show signs of friction material transfer.

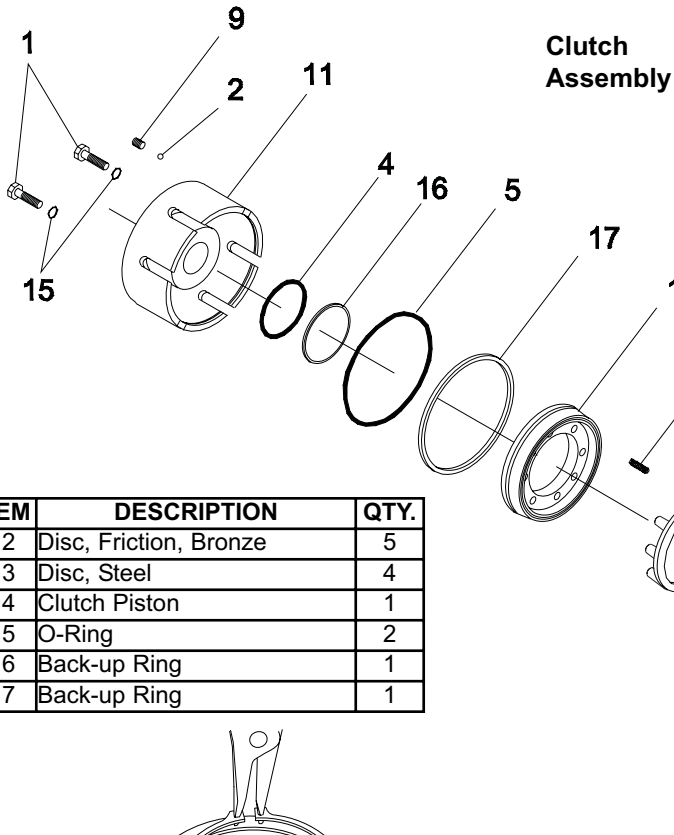

ITEM	DESCRIPTION	QTY.
1	Plug, O-Ring Flush	2
2	Steel Check Ball	1
3	Spring	8
4	O-Ring	1
5	O-Ring	1
6	Retaining Ring	1
7	Retaining Ring	2
8	Spring Retainer	1
9	Check Valve Seat	1
10	Pressure Plate	1
11	Clutch Housing	1

ITEM	DESCRIPTION	QTY.
12	Disc, Friction, Bronze	5
13	Disc, Steel	4
14	Clutch Piston	1
15	O-Ring	2
16	Back-up Ring	1
17	Back-up Ring	1

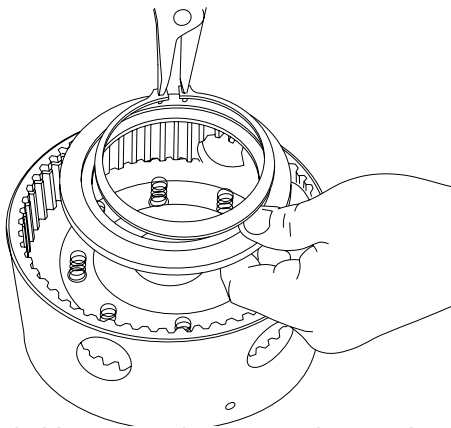

Using a suitable press, depress spring retainer (8) and remove retaining ring (6) and clutch spring retainer (8).

Remove the eight clutch piston return springs (3). During the rebuild of clutch assemblies, it is recommended to replace all eight springs. Minimum spring free length is 1.41 in. (35.8 mm) for springs in splined housings, and 1.16 in. (29.5 mm) for springs in slotted housings.

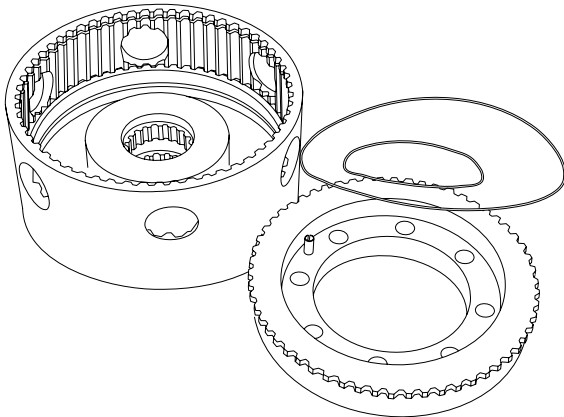

Turn the clutch housing over and tap on bench top to

remove clutch piston (14). Inspect piston for wear or damage.

Remove O-Rings and back-up rings from the piston. Replace O-Rings and back-up rings upon reassembly.

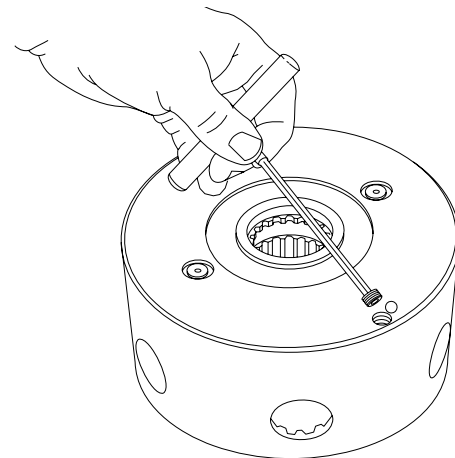

Remove the check valve seat (9) and steel ball (2) from the back side of clutch housing (11). Inspect for wear and make sure all foreign material that may restrict the steel ball seating action is removed.

Remove the two flush plugs (1) from the back side of the clutch housing.

ASSEMBLY

Thoroughly clean and inspect all components prior to assembly.

Install the steel check-ball (2) into the back side of clutch housing (11). Lightly coat threads of check valve seat (9) with Loc-tite 242 and install flush with the surface of the clutch housing. Make certain that the steel ball moves freely and no thread locking compound is in seat area.

Install the two flush plugs (1) into the back side of the clutch housing.

Install back-up rings (16 & 17) into grooves in clutch piston. Lubricate O-Rings (4 & 5) with hydraulic oil and install them in the grooves with the back-up rings.

i NOTE: *The concave (cupped) side of the back-up ring MUST always face the O-Ring. Back-up rings are toward the side of the piston that pushes against the clutch discs, as shown.*

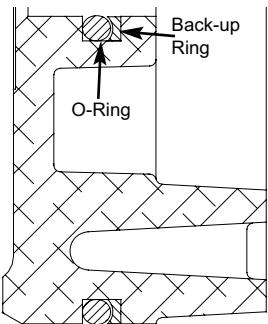

Lubricate the piston O-Ring sealing surface with hydraulic oil then align clutch piston teeth in clutch housing and push piston (14) into bottom of clutch housing (11).

Install spring retainer (8) over springs and align hole in retainer with roll pin (16) in clutch piston.

Using a suitable press against spring retainer (8) compress springs to expose the retaining ring groove. Install retaining ring (6) with the sharp edge of the inner diameter of the retaining ring facing away from the clutch springs.

i NOTE: *Pre-lubricate the clutch discs in winch lubricant before assembly.*

Install the discs by starting with a steel separator disc (13) (lugs on outside diameter) next to the piston and alternate with a friction disc (12) (teeth on inside diameter) until a total of five friction discs and five steel discs have been installed.

Install the pressure plate (10) and retaining ring (7).

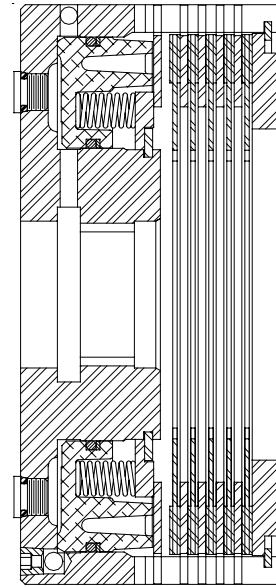

Completed Clutch Assembly

The assembled clutch must have .090 -.140 in. (2.3-3.6 mm) clearance between the pressure plate and the top friction disc with new clutch discs. If the clutch pack clearance exceeds .140 in. (3.6 mm), this indicates some wear of the discs. The friction discs are completely worn out and must be replaced if the clearance exceeds .200 in. (5.1 mm). If the clearance is less than .090 in (2.3 mm), this indicates that the clutch piston may not be fully retracted or some distortion of the discs may be consuming the clearance. Closely inspect and repair or replace components as required.

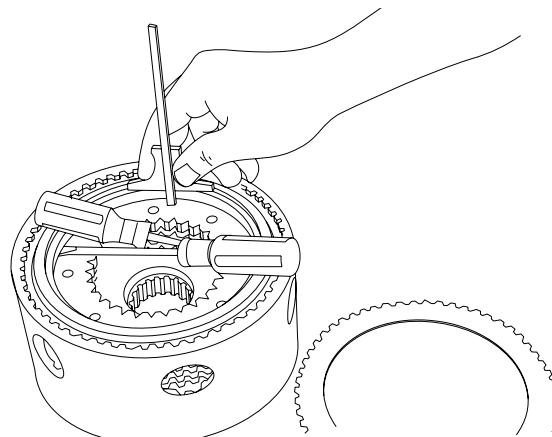

i TIP: To ease the measurement of the clutch assembly clearance, gently wedge two standard blade screwdrivers between the pressure plate and disc. Locate the screwdrivers 180° apart. Measure from the top of the pressure plate to the top of the disc while the screwdrivers hold the pressure plate wedged tightly against the retaining ring(s). Call this dimension "A".

Remove the screwdrivers and push the pressure plate down against the disc. Again, measure from the top of the pressure plate to the top of the disc. Call this dimension "B".

A-B = Clutch pack clearance; the distance the piston travels to compress the discs in the fully applied condition.

It may be advantageous to pre-align the clutch discs and hold them in position for assembly. To do this, remove the two flush plugs (1) from the back side of the clutch housing. Next, install the clutch onto the end of the clutch shaft splines. Install the brake hub onto the clutch shaft and into the clutch assembly, aligning all disc splines. Then, install two 3/8 in. NF x 1 capscrews through the flush plug

holes to push the clutch piston against clutch discs and hold them in position. Only tighten the capscrews enough to keep the clutch discs from moving in the housing. Remove the brake hub and clutch shaft. The clutch assembly is now ready for installation.

CAUTION

After installation of the clutch, be sure to remove the two 3/8 in. NF X 1 capscrews from the back side of the clutch housing and install the two flush plugs (1) in their place. Failure to remove the capscrews or install the flush plugs will result in clutch assembly damage.

BRAKE ASSEMBLY SERVICE

The brake system consists of a multi-disc, spring-applied, hydraulically released oil brake. Under normal conditions, no periodic brake adjustment is required.

STANDARD BRAKE

The brake may be used on an **intermittent** basis to lower a load. However, partially releasing the brake and lowering the load through the brake causes excessive heat build-up after repeated cycles. Allow the brake to cool between lowering cycles to avoid overheating and brake damage. Lowering of loads should be accomplished by moving the powershift lever to the reel-out position, completely engaging the reel-out clutch and using the tractor throttle to vary the lowering speed.

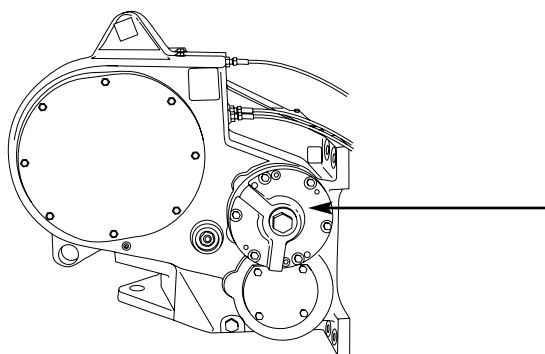

The brake assembly is located on the right hand side of the winch in the upper winch case bore.

The winch gear train is connected to the brake assembly by the brake hub, attached to the end of the clutch shaft. The brake hub is splined to eight friction discs (15). The friction discs are alternately stacked between steel discs (16), which are contained in the brake housing (14). The brake housing is anchored to the winch case.

Two large disc type springs (18) exert a tremendous force against the brake piston (13) and pressure plate (11) to hold the brake disc pack compressed, locking the winch gear train to the winch case.

Whenever the operator applies a clutch or shifts to "Brake-Off", hydraulic pressure is directed to the brake chamber to overcome the spring force and relieve the compression of the discs. When released, the brake hub and gear train can turn as the brake friction discs slip freely between the brake steel discs.

If the operator returns the controls to the neutral "Brake-On" position, the hydraulic pressure will be exhausted from the brake chamber and the brake springs will quickly reapply to lock the winch gear train to the brake housing through the brake discs.

In most applications, the brake assembly may be removed for service with the winch mounted on the tractor.

BRAKE ASSEMBLY REMOVAL

Drain oil from the winch into a suitable container and recycle or dispose of used oil in an environmentally responsible manner.

Remove the six 1/2 in. capscrews securing the brake assembly to the winch case. Do not remove the two 3/8-in. capscrews (2) which secure the bearing carrier to the brake housing at this time.

The brake housing has two through-tapped holes which may be used with 1/2 in. NC jackscrews to push the brake housing out of the winch case bore.

If jackscrews are not available, the brake may be removed from the winch case by carefully using a prybar between the brake housing and winch case. Be careful not to damage the shim set.

Remove the brake assembly from the winch case. The brake assembly weighs approximately 50 lbs (22.7 kg). Retain the shim set for reassembly.

DISASSEMBLY

Place the brake assembly onto a work bench with the disc end down. Remove the two 3/8 in. capscrews (2) securing the bearing carrier (17) to the brake housing (14) and remove the carrier. Remove the retaining ring from inside of the carrier and remove the rotary seal and O-Ring assembly; replace as required. Inspect the bearing cup in the bearing carrier; replace as required.

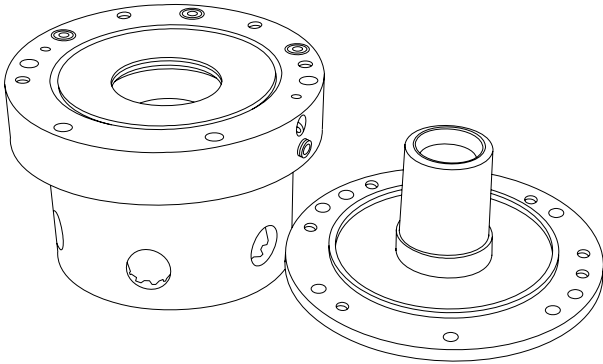

Remove and discard the three O-Rings (4) from the oil port grooves in the brake housing. Remove the two brake springs (18). Note the position of the springs for reassembly.

Place the brake assembly on the work bench with the disc end facing up.

Remove retaining ring (10) and pressure plate (9).

Remove the friction discs and steel discs (15 & 16).

Inspect the friction discs for wear and flatness. Original friction disc thickness is .138-.144 in. (3.5-3.8 mm). The oil groove depth of a new disc is .015 in. (.38 mm) minimum. Replace friction discs if oil groove is .005 in. (.13 mm) or less, the disc is not flat or friction material is worn unevenly.

Inspect the steel discs (16) for scoring and warping. Replace steel discs if they are not flat beyond .015 in. (.4 mm), heat discolored, or show signs of friction material transfer.

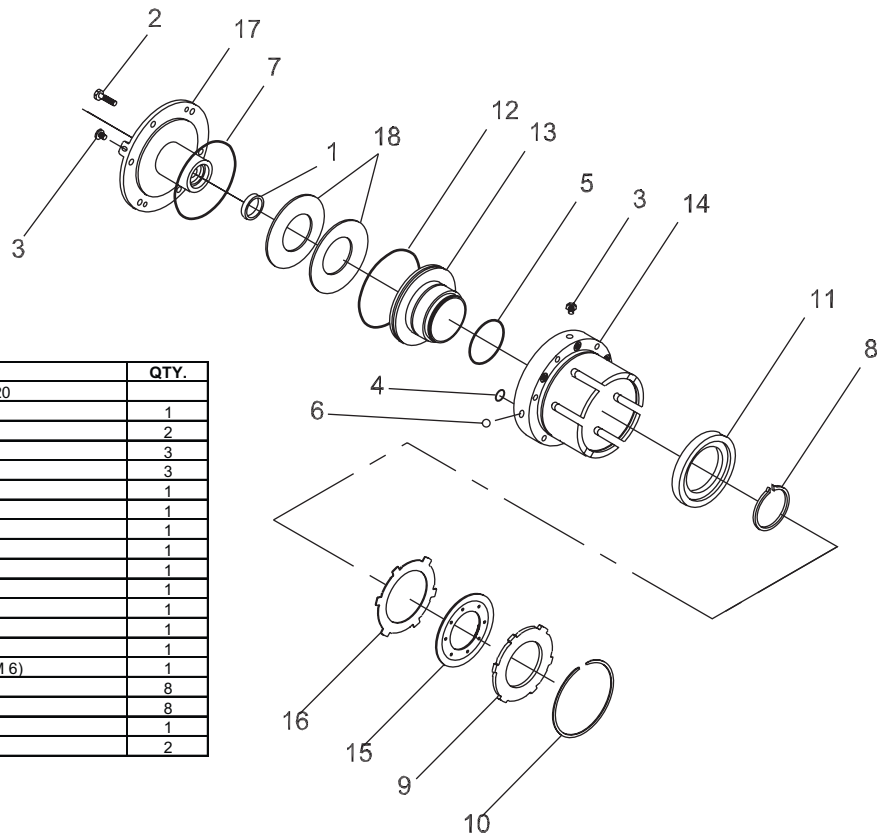

ITEM	PART NO.	DESCRIPTION	QTY.
-	82896	BRAKE ASSEMBLY, STD - INCLUDES 1 - 20	
1	18049	BEARING CUP	1
2	104309	CAPSCREW, HEX HEAD (3/8 - 16 X 1)	2
3	26686	PLUG, HEX SOCKET (-6 ORB)	3
4	22454	O-RING	3
5	31579	O-RING	1
6	70126	STEEL BALL (PRESSED INTO HOUSING)	1
7	22358	O-RING	1
8	69807	RETAINING RING	1
9	103108	PRESSURE PLATE	1
10	103111	RETAINING RING	1
11	103000	PRESSURE PLATE	1
12	70140	O-RING	1
13	102999	BRAKE PISTON	1
14	102931	BRAKE HOUSING - (REQUIRES 1 OF ITEM 6)	1
15	101378	DISC - FRICTION - BRONZE	8
16	101377	DISC - STEEL - .104 in. (2.64 mm)	8
17	103414	BRAKE CARRIER	1
18	70255	BRAKE SPRING	2

Remove retaining ring (8) and pressure plate (11). Push brake piston (13) free of brake housing. Remove and discard O-Rings (5 & 7) from the inner grooves of the brake housing.

ASSEMBLY

Thoroughly clean and carefully inspect all components for wear or damage prior to reassembly. Replace components as required.

Install brake piston O-Rings (5,7) into grooves of brake housing. Lubricate O-Rings after installation with winch oil or light general purpose grease.

Lubricate brake piston sealing surfaces and install brake piston (13) into the brake housing until fully seated.

Install pressure plate (11) over piston hub (13) with the large diameter end facing up. Secure in place with retaining ring (8).

BRAKE DISC PACK INSTALLATION

The brake pack requires no adjustment.

Position the brake housing with the disc end of the housing facing up.

If the clutch shaft group has been disassembled, install the brake hub into the brake housing to keep the friction discs aligned.



NOTE: *Pre-lubricate the discs in winch lubricant prior to assembly.*

Install the discs by starting with a friction disc (15) (teeth on inside diameter) and alternate with a steel disc (16) (lugs on outside diameter) until a total of eight friction and eight steel discs have been installed.

Install the outer pressure plate (9) and secure in place with a retaining ring (10).

BRAKE SPRING INSTALLATION

Position the brake housing with the disc end facing down.

⚠ WARNING ⚠

One brake spring must “nest” within the shallow cavity on the outside of the brake piston while the other brake spring will “nest” in the shallow cavity in the bearing carrier. If the springs slip out of the cavities during assembly, brake component damage and improper brake operation may occur. Improper brake operation may lead to loss of load control which may result in property damage, injury or death.

Install the two brake springs (18) into the housing against the brake piston with the dished (concave) side of the springs facing away from each other.

Install three o-rings (4) into the oil port grooves on the outer end of the brake housing.

Lubricate and install the rotary seal with o-ring into the bore of the bearing carrier cover, with the flat side of the rotary seal facing toward the back-up washer and retaining ring. Secure in place with the retaining ring.

If the bearing cup was removed, install a new bearing cup (1) into the bearing carrier cover.

Install o-ring (7) into the groove on the pilot of the bearing carrier.

Install the brake carrier (17) onto the brake housing while aligning the oil ports between the two housings. Install the two 3/8 in. capscrews (2) and tighten to 31 lb•ft (42 N•m) torque.

BRAKE ASSEMBLY TEST PROCEDURE

The following test procedure may be used to check the condition of the brake piston seals and the actual pressure required to fully release the brake.

Lubricate and install an o-ring (4) into the grooved brake housing port labeled with a “B” cast onto the bearing carrier.

Clamp a piece of steel bar over the port now sealed by the o-ring.

Locate the external brake release port next to the “B” cast into the bearing carrier. The port is 1/4 in. NPT on early units and -6 ORB on current units. Attach a hand pump with an accurate 0-500 psi (0-3450 kPa) gauge teed into the line.

With the hand pump, slowly increase pressure applied to the brake and record what pressure is required to fully release the brake and permit free movement of the brake discs with a screwdriver.

The brake should be fully released at approximately 230 - 250 psi (1590 - 1720 kPa).

Continue to increase pressure to 350 psi (2410 kPa). Close the hand pump valve and let stand for five minutes. If there is any loss of pressure in five minutes, the brake cylinder should be disassembled for inspection of the seals and sealing surfaces.

INSTALLATION

Refer to “Clutch Shaft Service” for additional information.

Install three o-rings in the grooves on the brake housing and three o-rings in the grooves on the winch case.

Install the original shim set between the brake housing and winch case. If the shim set must be replaced, refer to the “Clutch Shaft Service” section for additional information.

Lubricate and install the o-ring into the groove on the outer diameter of the brake housing.

Install the brake assembly into the winch case, aligning all ports of winch case, shim set and brake assembly.

Install the six capscrews which secure the brake housing to the winch case. Tighten to 75 lb•ft (102 N•m) torque.

Refill winch to proper level with recommended oil.

IDLER SHAFT GROUP

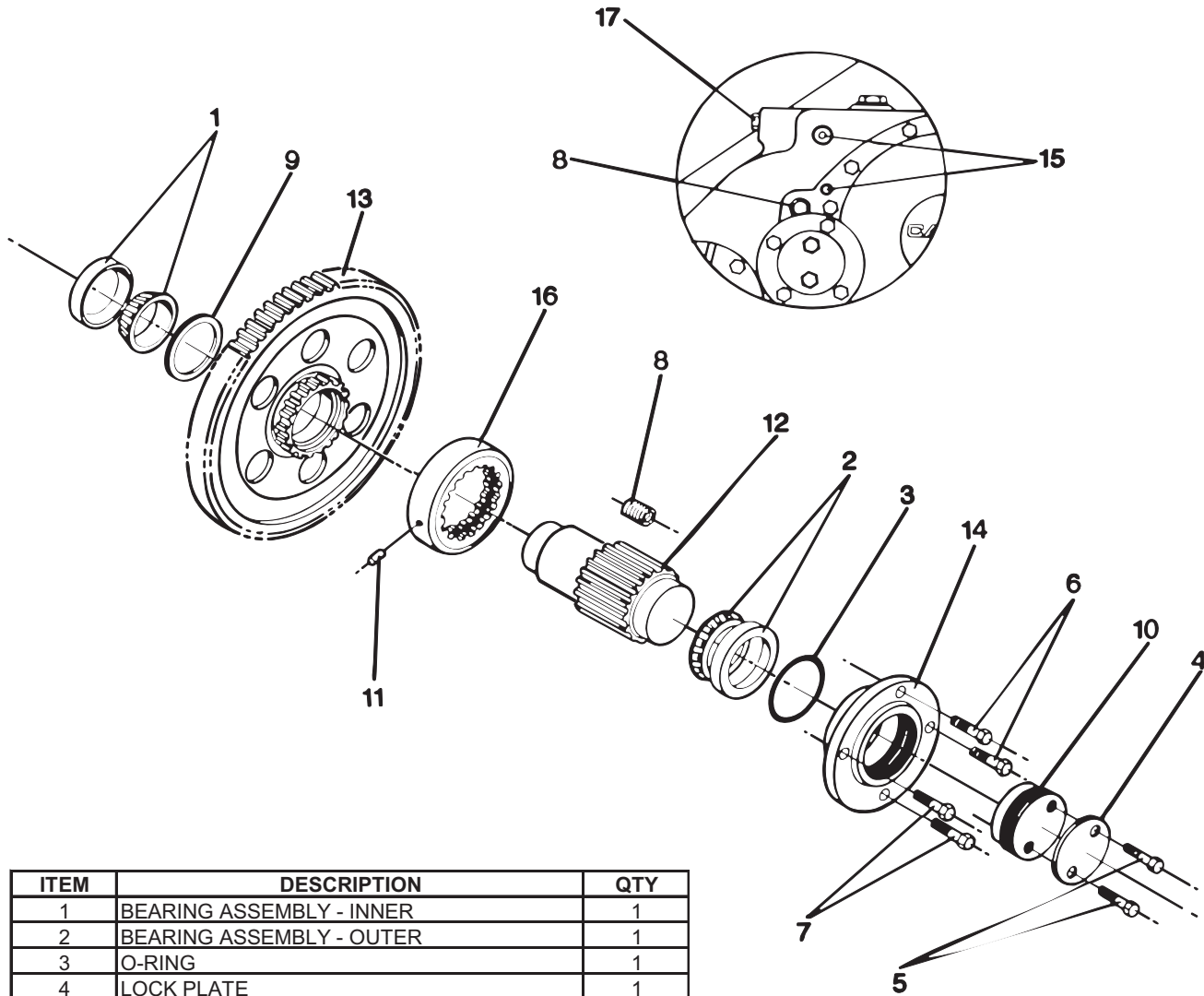

ITEM	DESCRIPTION	QTY
1	BEARING ASSEMBLY - INNER	1
2	BEARING ASSEMBLY - OUTER	1
3	O-RING	1
4	LOCK PLATE	1
5	CAPSCREW, HEX HEAD (1/2 - 13 X 3/4 G5)	2
6	CAPSCREW, HEX HEAD (1/2 - 13 x 1-1/4 G5)	2
7	CAPSCREW, HEX HEAD (1/2 - 13 X 2 G5)	2
8	PLUG, SOCKET HEAD	1
9	THRUST WASHER	1
10	ADJUSTER	1
11	ROLLPIN	1
12	PINION, SECOND REDUCTION	1
13	GEAR, FIRST REDUCTION	1
14	CARRIER, IDLER SHAFT	1
15	SCREW, SOCKET HEAD	2
16	COLLAR	1
17	CAPSCREW HEX HEAD (3/4 - 16 X 1-1/4 G5)	1

The idler shaft components, which include the first reduction gear and second reduction pinion are located on the left hand side of the winch, when viewed from the rear.

Removal of these components for repair may be accomplished with the winch mounted to the tractor.

REMOVAL

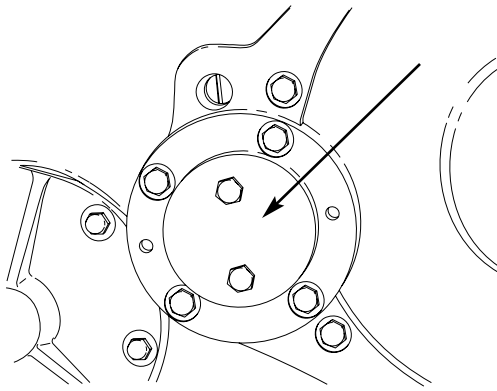

Drain oil from winch as described in the "Preventive Maintenance" section of this manual.

Remove the two capscrews (5) and lock plate (4) from the idler shaft bearing carrier (14) and adjuster assembly.

Remove the four capscrews (6,7) securing the idler shaft bearing carrier (14) and adjuster to the winch. Use two capscrews as jackscrews and remove the carrier and adjuster assembly.

Note the location of the two long capscrews for reassembly.

Inspect the bearing cup and replace as required.

Turn the adjuster (10) counter-clockwise and remove it from the bearing carrier. Remove and discard the o-ring (3) from the carrier.

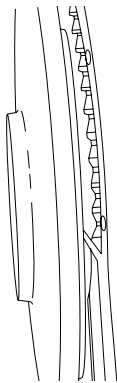

Remove the capscrews from the large diameter second reduction shaft bearing carrier cover (16) and carefully remove the cover.

CAUTION

Use a pry bar between the bearing carrier cover and the second reduction drum drive gear to unseat the ball bearing from the cover.

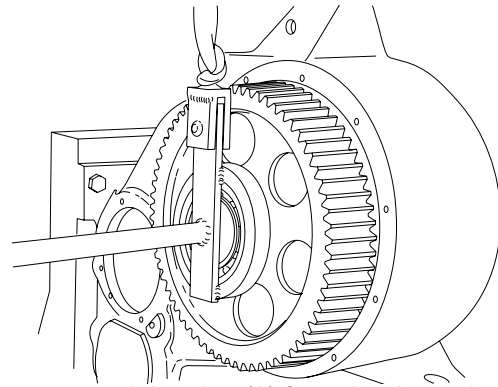

Remove retaining ring (8) from the drum shaft. With a lifting fixture or suitable sling, remove the drum drive gear from the drum shaft. Gear weighs approx. 110 lbs. (50 kg).

Remove cable drum shaft. Refer to Cable Drum Group for shaft removal.

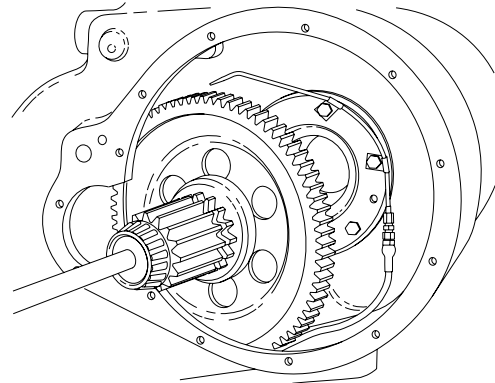

Move the first reduction gear and pinion assembly (12, 13) outward to unseat the inner bearing cone from the bearing cup in the winch case wall.

Carefully move the gear and pinion assembly into the drum drive gear opening and remove from winch case.

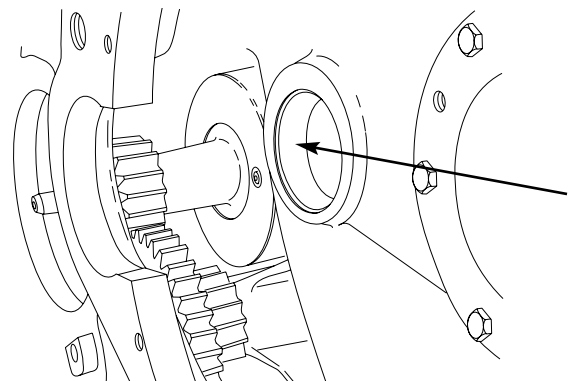

Inspect the bearing cup in the winch case wall and replace as required.

Support the first reduction gear (13) in the suitable hydraulic press and press the second reduction pinion (12) free of the inner bearing cone.

Support the second reduction pinion and remove the outer bearing cone.

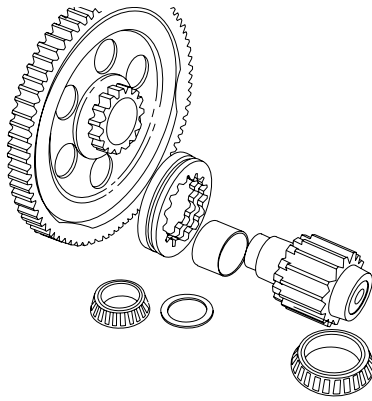

Inspect the bearing cone (1) and thrust washer (9) for wear or damage and replace as required.

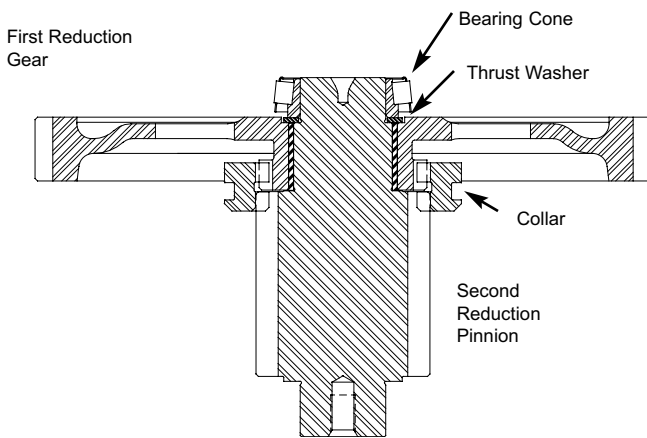

ASSEMBLY

Place the second reduction pinion (12) on a flat surface with the stepped end facing up.

Install the splined collar over the first reduction gear. Secure the collar in place with a $\frac{1}{4} \times 1 \frac{1}{4}$ in. roll pin. The roll pin will protrude $\frac{1}{2}$ in. (13 mm) from the outer diameter of the collar and be driven into the groove behind the gear teeth of the first reduction gear.

Install the first reduction gear and collar over the bushing, aligning the second reduction pinion (12) teeth with the splined collar teeth.

Install thrust washer (9) over the second reduction pinion and into the recess of the first reduction gear.

Install the inner bearing cone over the end of the second reduction pinion. Press the bearing cone until firmly seated against thrust washer (9).

Install the outer bearing cone over the second reduction pinion. Press the bearing cone until firmly seated against the pinion shoulder.

Lubricate and install the bearing cup into the inner wall of the winch case.

Place the first reduction gear and second reduction pinion assembly into the winch case opening, aligning the inner bearing cone within the bearing cup.

Install the drum shaft and drum drive gear. Refer to Cable Drum Group.

Make certain that the lube tube is aimed toward the second reduction pinion gear before installing the second reduction gear and drum drive shaft. Make certain that the lube tube will not rub against any gears.

Apply silicone sealant 730 RTV or equivalent to the sealing surface of the large diameter second reduction gear bearing carrier cover and install it into the winch case. Apply thread sealant to the capscrews and install them finger tight. DO NOT tighten capscrews at this time.

Lubricate and install o-ring (3) into the groove of the bearing carrier (14). Install threaded adjuster (10) into the bearing carrier until the adjuster passes through the o-ring.

Install the bearing cup into the bearing carrier until it is seated against the threaded adjuster.

Apply silicone sealant 730 RTV or equivalent to the mounting surface of the bearing carrier.

Install the bearing carrier assembly into the winch case. Apply thread sealant to the capscrews and tighten to 75 lb•ft (102 N•m) torque. Tighten the capscrews around the large bearing carrier cover to 75 lb•ft (102 N•m) torque.

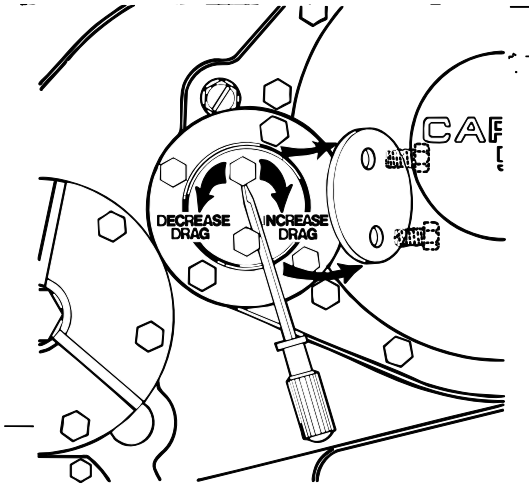

⚠ CAUTION ⚠

Do not back off adjuster more than 1/4 turn as this allows excessive shaft end-play and may cause gear train misalignment, accelerated wear and noise.

Refill winch to the proper level with recommended oil.

Using a long screwdriver or pry bar, turn the threaded adjuster clockwise until tight. Tap the adjuster with a hammer to seat the bearing and continue turning until the adjuster can no longer be tightened. Back the adjuster out no more than 1/16 turn maximum and secure with lock plate and capscrews. Tighten capscrews to 75 lb•ft (102 N•m) torque.

i **NOTE:** Tightening the threaded adjuster pushes the tapered bearing cup (outer race) into closer contact with the bearing cone and increases the bearing drag; much like tightening a wheel bearing nut on an automobile or truck. The snug fitting bearing cup will NOT move outward with the threaded adjuster when the adjuster is loosened. The winch must be operated under load for a brief period to allow the gear train load to push the outer bearing cup out against the threaded adjuster before a reduction in bearing drag can be noticed.

FOURTH SHAFT GROUP

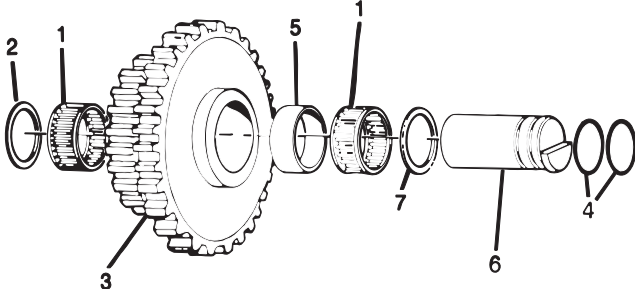

ITEM	DESCRIPTION	QTY.
1	Roller Bearing	2
2	Thrust Washer - 0.062 in. (1.58 mm)	2
3	Cluster Gear	1
4	O-Ring	1
5	Spacer	1
6	Countershaft Pin	1
7	Thrust Washer - 0.217 in. (5.5 mm) - 50B/70A	1

This group contains a cluster gear which provides additional reduction in the gear train.

DISASSEMBLY

Drain oil from winch as described in the “Preventive Maintenance” section of this manual.

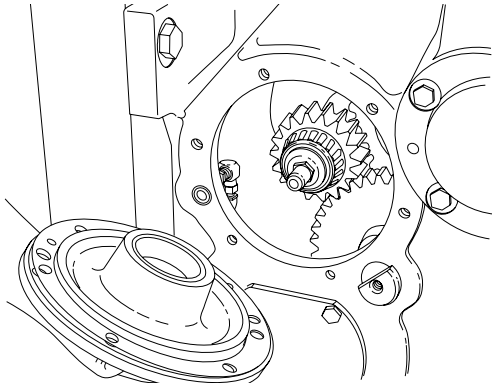

Remove the six capscrews then remove the left-hand clutch shaft bearing carrier. Retain the shim set for reassembly.

Remove the first reduction drum drive gear, second reduction gear and pinion, freespool shift rail and yoke, if equipped with freespool. Refer to “Idler Shaft Group” section of this manual for additional information.

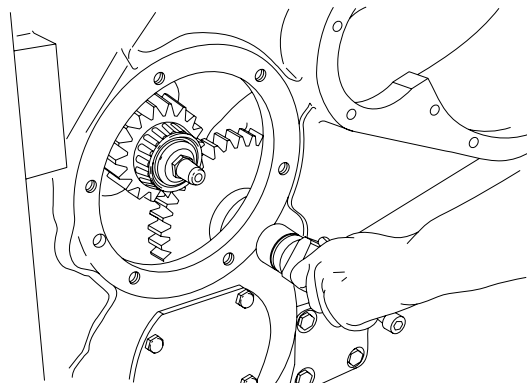

Install a long, ½ in. NC, capscrew into the end of the countershaft pin (6) to serve as a handle. Support the cluster gear (3) and remove the countershaft pin.

⚠ CAUTION ⚠

The inner and outer thrust washers (2 & 7) will drop down into the winch case when the fourth shaft is removed. Be sure to retrieve them prior to assembly. Gear train damage will occur if these thrust washers are omitted or left in the bottom of the winch case.

Thoroughly clean all parts and inspect for damage and wear. The bearing rollers should not exhibit any irregularities. If the rollers show any sign of spalling, corrosion, discoloration, material displacement or abnormal wear, the bearing should be replaced. Likewise, the cage should be inspected for unusual wear or deformation, particularly the cage bars. If there is any damage that will impair the cage’s ability to separate, retain and guide the rollers properly, the bearing should be replaced. The thrust washer contact areas should be free from any surface irregularities that may cause abrasions or friction. The gears and shaft should be inspected for abnormal wear or pitting. Replace if necessary.

ASSEMBLY

Lubricate and install new o-ring (4) into the groove on the countershaft pin (6). Lubricate and install two roller bearings (1) separated by a spacer (5) into the bore of the cluster gear (3).

Position the cluster gear (3) and outer thrust washer (2 or 7) in the winch case and at the same time, insert countershaft pin (6) through the bore into the thrust washer and cluster gear.

Position the inner thrust washer (2) in the winch case between the cluster gear and the inner case wall then fully install the countershaft pin.

Rotate the countershaft pin so that the slotted end is properly positioned to permit clutch shaft bearing carrier installation.

Install the first and second reduction gears and freespool linkage, if equipped. Refer to the “Idler Shaft Group” section for additional information. Install the shim set onto the clutch shaft bearing carrier and install the bearing carrier into the winch case. Tighten the capscrews to 75 lb•ft (102 N•m) torque.

i **NOTE:** Be careful to properly align the clutch pressure oil port in the winch case, shims and bearing carrier.

Refill winch to the proper level with recommended oil.

CABLE DRUM GROUP

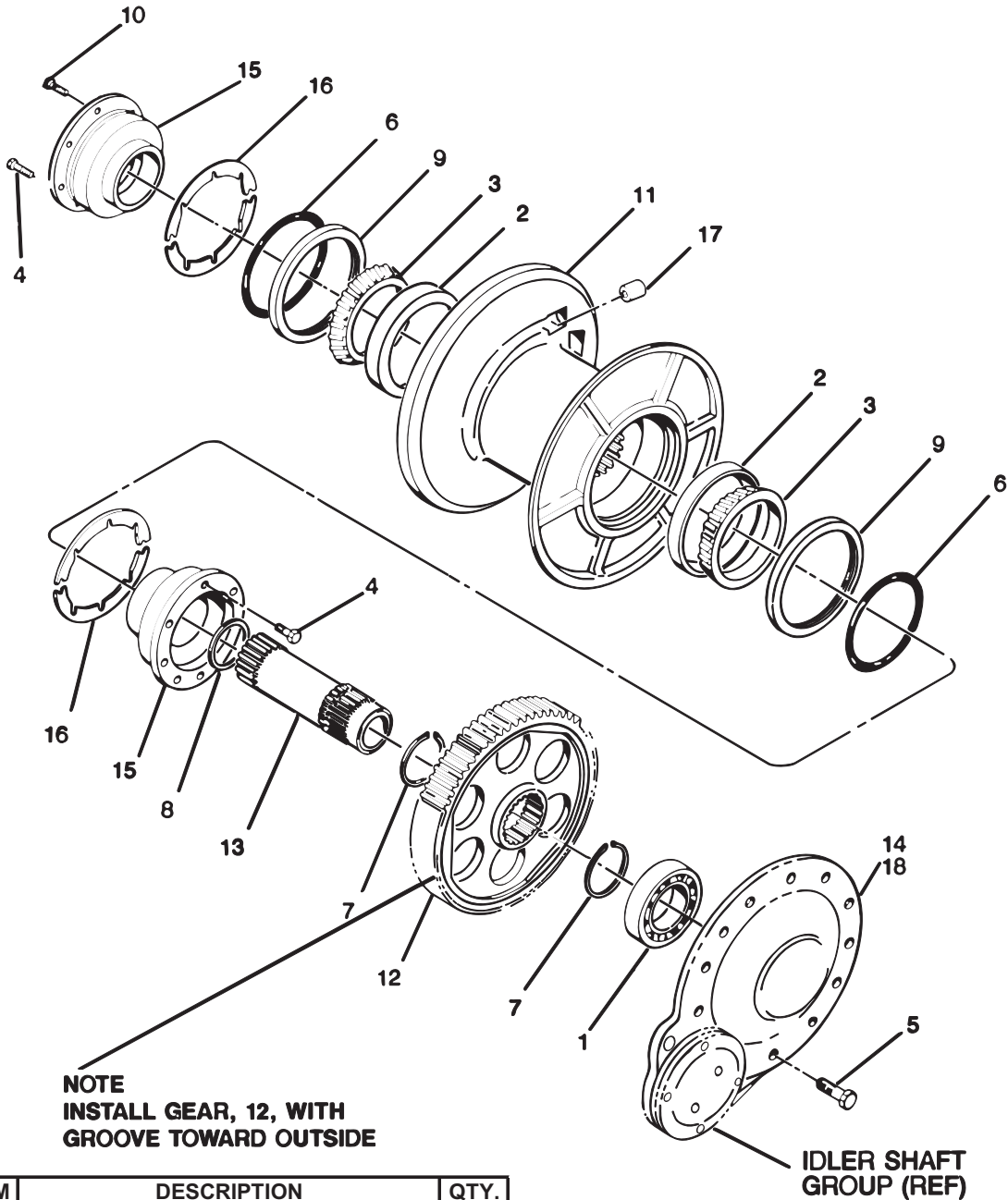

NOTE
INSTALL GEAR, 12, WITH
GROOVE TOWARD OUTSIDE

ITEM	DESCRIPTION	QTY.
1	Ball Bearing	1
2	Bearing Cup	2
3	Bearing Cone	2
4	Capscrew, Hex Head	10
5	Capscrew, Hex Head	11
6	O-Ring	2
7	Retaining Ring	2
8	Retaining Ring	1
9	Oil Seal	2
10	Capscrew, Socket Head	1
11	Cable Drum	1
12	Gear, Second Reduction	1
13	Shaft, Second Reduction	1
14	Bearing Carrier/Cover	1
15	Drum Bearing Carrier	2
16	Shim Set	1
17	Cable Ferrule	1
18	NO GASKET, Use RTV 730 or equivalent	---

DISASSEMBLY

⚠ WARNING ⚠

Discharge accumulator oil supply before removing any hydraulic lines or servicing winch. Personal injury may result from sudden release of oil pressure. To discharge the accumulator, stop engine, slowly cycle power shift control handle into full Reel-In then Reel-Out positions a minimum of five (5) times.

⚠ WARNING ⚠

Hot oil may cause injury. Make certain the oil has cooled to a safe temperature (less than 110°F/43°C) before servicing the winch.

Remove the right hand winch housing cover.

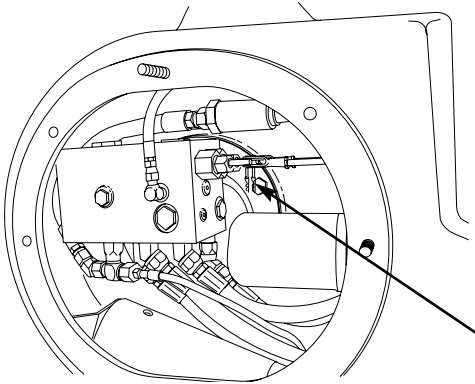

Remove the clevis pins securing the control cables to the valve spools. Remove the capscrew (19) securing the control valve to the winch case and lower the control valve in the winch case. Disconnect the pressure gauge line from the control valve. Remove the control valve from the winch case while attached to the remaining hoses.

Remove the two capscrews and lock plate from the idler shaft bearing carrier and adjuster assembly.

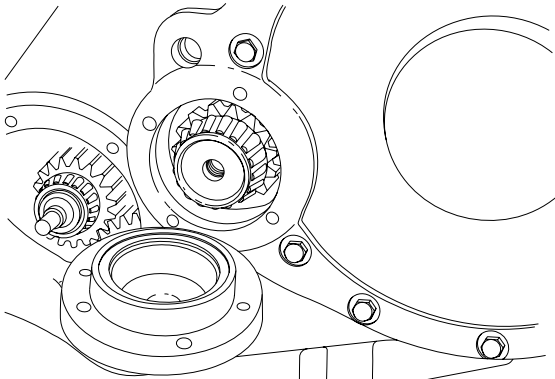

Remove the four capscrews securing the idler shaft bearing carrier and adjuster to the winch. Use two capscrews as jackscrews to remove the carrier from the winch.

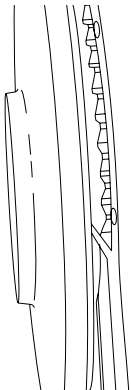

Remove the capscrews (5) from the large diameter bearing carrier cover (14) and remove the cover.

⚠ CAUTION ⚠

Use a pry bar between the bearing carrier cover and the second reduction drum drive gear to unseat the ball bearing from cover. Do not allow the cable drum drive gear to slide free of the winch case. The gear assembly may fall from the cover and cause personal injury. Gear and shaft weigh approximately 125 lb (56 kg).

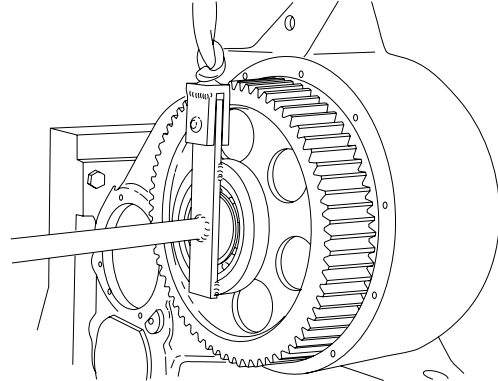

Remove the 2nd reduction drum drive gear and shaft assembly (12,13) from the winch.

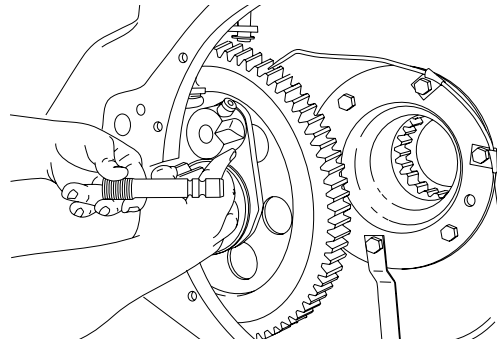

If the winch is equipped with freespool, remove the shift rail and freespool shift collar and yoke assembly from the first reduction gear.

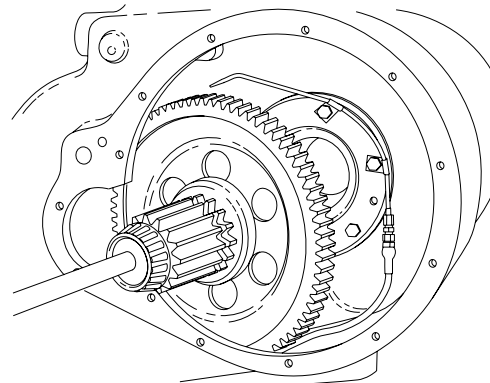

Move the first reduction gear and pinion assembly outward to unseat the bearing cone from the bearing cup in the case wall. Carefully move the gear and pinion assembly into the drum drive gear opening and remove them from the winch case.

Support the cable drum with a nylon sling and remove capscrews (4) from the right hand drum bearing carrier (15). Note the location of the socket head capscrew (10) necessary for control valve alignment. Using jackscrews,

remove the drum bearing carrier.

Remove capscrews (4) from the left hand drum bearing carrier (15) and lube tube clamps. Using jackscrews, remove the drum bearing carrier.

i **NOTE:** *Split shims (16) are located between bearing carriers (15) and the winch case. Retain the shims in their original location for reassembly.*

Inspect bearing cones (3) and replace as required.

Remove and discard o-rings (6) from the drum bearing carriers.

Remove cable drum oil seals (9).

Inspect bearing cups (2) and replace as required.

Check the condition of snap ring (8) in the splined bore of the cable drum and replace as required.

ASSEMBLY

Install bearing cups (2) into cable drum (11). With a .002 in. (.05 mm) feeler gauge, make certain cups are fully seated against the shoulder in the cable drum bore.

Install oil seals (9) into the cable drum with the spring side of the seal facing toward the cable drum.

If it was removed earlier, install snap ring (8) into the groove in the splined bore of cable drum with sharp edge of the snap ring toward the center of the drum.

Lubricate and install o-rings (6) onto the cable drum bearing carriers.

Lightly lubricate bearing cones (3) with multi-purpose bearing grease and install onto the bearing carriers.

Suspend the cable drum in the winch case with the cable ferrule pocket on the right hand side. Lubricate the bearing cups (2) and oil seals (9) with general purpose grease. Install the right hand bearing carrier into the winch case and cable drum using the original shim pack (16), if available. Apply non-hardening thread sealant to the capscrews and tighten to 75 lb•ft (102 N•m) torque. Make certain the socket head capscrew (10) is in the proper location for control valve clearance.

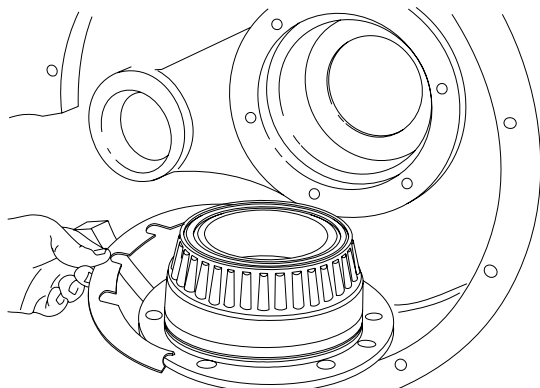

Install the left hand drum bearing carrier (15) with the original shim pack, if available. Secure the lubrication tube and oil line into proper position with clamps. Apply non-hardening thread sealant to capscrews and tighten to

75 lb•ft (102 N•m) torque.

Attach a dial indicator to the left hand bearing carrier and position the indicator stem against the retaining ring (8) in the cable drum bore. With a large screwdriver, pry drum from side to side to check for end play of .005 - .010 in. (.13 - .25 mm). Add or remove shims (16) as required, while keeping the cable drum centered in the winch case.

i **NOTE:** *It is best to keep the drum end play close to the minimum value given above.*

Install the first reduction gear and pinion assembly into the winch. If the winch is equipped with freespool, install the shift rail and freespool shift collar and yoke. Refer to the "Idler Shaft Group" section of this manual for additional information.

If the second reduction gear and shaft had been disassembled, install the second reduction gear (12) onto shaft (13) and secure in place with two retaining rings (7). Lightly pack bearing (1) with general purpose bearing grease and press onto shaft (13).

Install second reduction gear and shaft assembly into the winch while meshing the gear teeth with the pinion and the shaft splines with the drum.

Clean the mating surface of the winch case and bearing carrier cover (14). Apply silicone sealant 730 RTV or equivalent to the winch case.

Install the bearing carrier cover into the winch. Apply non-hardening thread sealant to the capscrews (5) and install finger tight.

Apply silastic sealant to the cleaned surfaces of the idler shaft bearing carrier. Install the idler shaft bearing carrier and tighten the capscrews to 75 lb•ft (102 N•m) torque. Tighten all remaining cover capscrews to 75 lb•ft (102 N•m) torque.

Adjust the idler shaft bearing adjuster per instructions found in "Idler Shaft Group" section of this manual. Install adjuster lock plate and tighten capscrews to 75 lb•ft (102 N•m) torque.

Install the pressure gauge line on the control valve. Place the control valve into position over the special socket head capscrew (10). Apply non-hardening thread sealant to capscrew (19) and tighten to 75 lb•ft (102 N•m) torque. Install the control cables to the valve spools and verify proper adjustment as described in the "Winch Removal and Installation" section of this manual.

Install the winch housing cover with a new gasket as required. Apply non-hardening thread sealant to the capscrews and tighten to 75 lb•ft (102 N•m) torque.

Refill winch with recommended lubricant.

CONTROL VALVE SERVICE

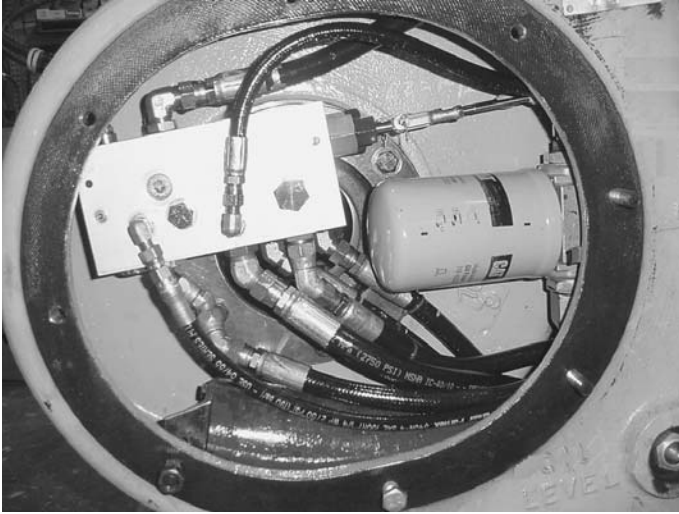

The control valve performs two essential duties:

1. Maintains a relatively constant pressure oil supply for reliable operation of the brake and clutches.
2. Converts the operator's mechanical signals, from control levers and cables, into hydraulic force to apply the directional clutches and release the spring applied brake.

The control valve contains several poppets, spools and check valves built into sub-assembly cartridges to perform these duties. These cartridges are installed into a precisely machined, solid aluminum housing. All oil ports and cartridge ports are labeled with the letter codes mentioned in the text below. The function of these components can best be explained by dividing them into two "systems":

- A. Pressure Maintenance System
- B. Directional Control System

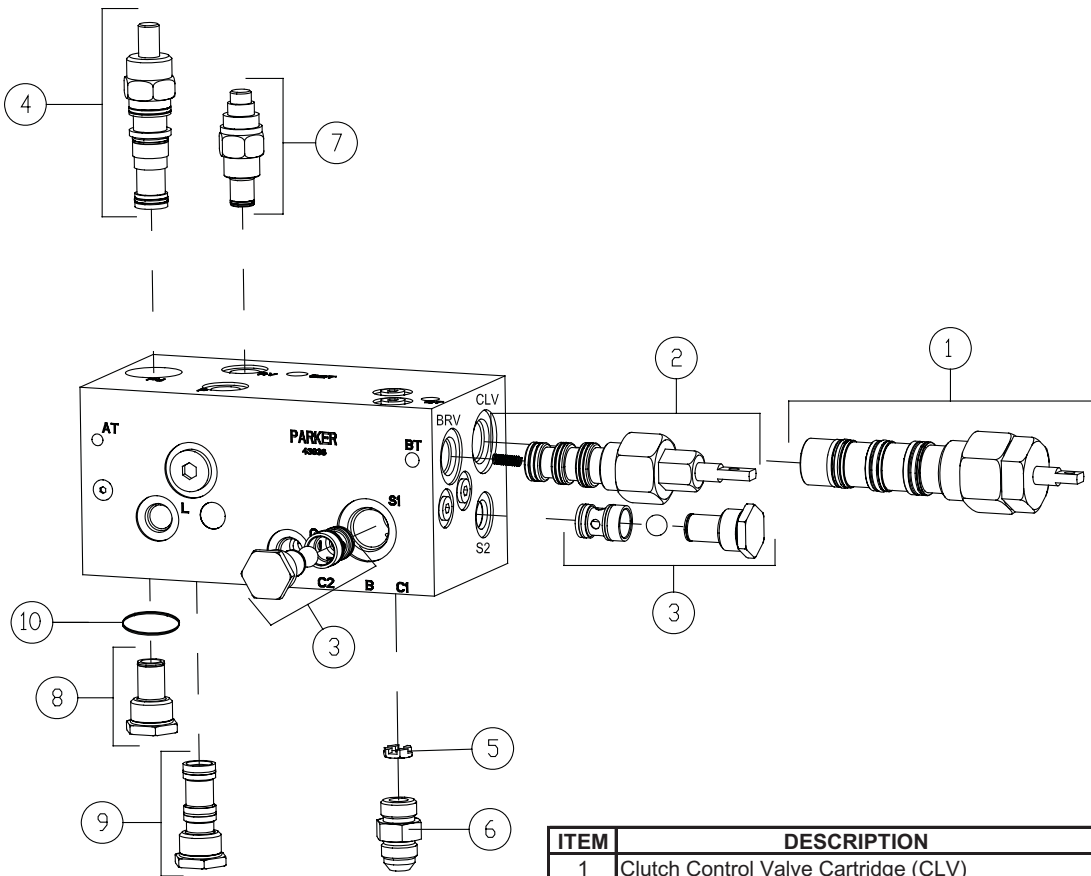

ITEM	DESCRIPTION	QTY	TORQUE VALUE	
			lb-ft	N-m
1	Clutch Control Valve Cartridge (CLV)	1	55	75
2	Brake Control Valve Cartridge (BRV)	1	35	48
3	Shuttle Valve Assembly (S1/S2)	2	25	34
4	Differential Pressure Unloading Cartridge (PU)	1	20	27
5	Orifice (B)	1	-	-
6	Adapter - -8 ORB -8 JIC (B)	1	20	37
7	Relief Valve Cartridge (RV)	1	20	27
8	Check Valve Cartridge (CV)	1	30	41
9	Logic Control Cartridge (LC)	1	30	41
-	Plug -8 ORB	1	28	38
-	Plug -6 ORB	2	13	18
-	Plug -4 ORB	7	7	10
-	Plug -2 ORB	3	3.7	5

Pressure Maintenance System

The pressure maintenance system operates continuously to keep the directional control system supplied with oil at 320-400 PSI (2210-2760 kPa) for reliable brake release and clutch application. The pressure maintenance system consists of the following components:

- CV – Check valve cartridge
- PU – Differential pressure unloading cartridge
- RV – Relief valve cartridge
- LC – Logic control cartridge
- A – Accumulator

CHARGING

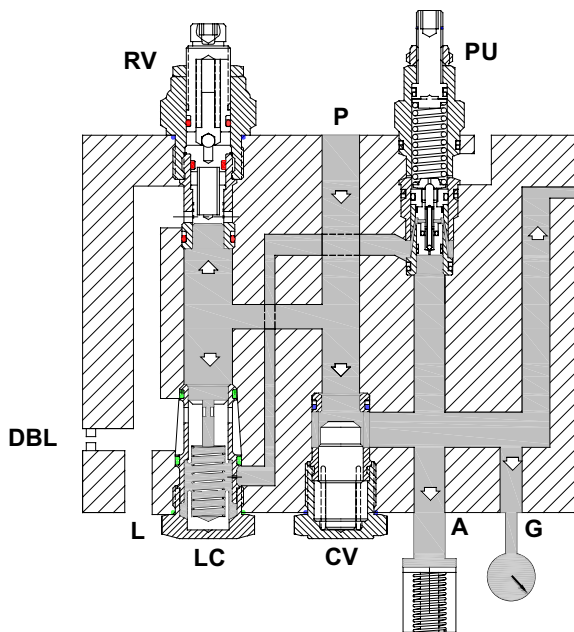

Supply oil from the pump passes through the filter and enters the top of the control valve housing at port “P”. The oil flows toward the relief valve (RV), logic cartridge (LC) and past the check valve (CV). After opening the check valve (CV) the oil pushes against the differential pressure unloading valve (PU) cartridge and continues on to the brake and directional control spool valves. The oil also exits the control valve at port “A” to fill the accumulator.

As the accumulator fills with oil, the pressure acting on all the cartridges increases. The relief spool in the logic control cartridge (LC) is held closed by a light spring. In addition to the spring force, a small amount of oil will pass through the orifice in the relief spool to fill the spring cavity behind the spool. A small passage through the side of the LC cartridge directs oil from the spring cavity to the center cavity of the differential pressure unloading cartridge (PU). The center cavity of the PU cartridge is closed at this time. Whatever pressure is seen at port “A” is also seen at port “P” and in the spring cavity of the LC cartridge.

UNLOADING

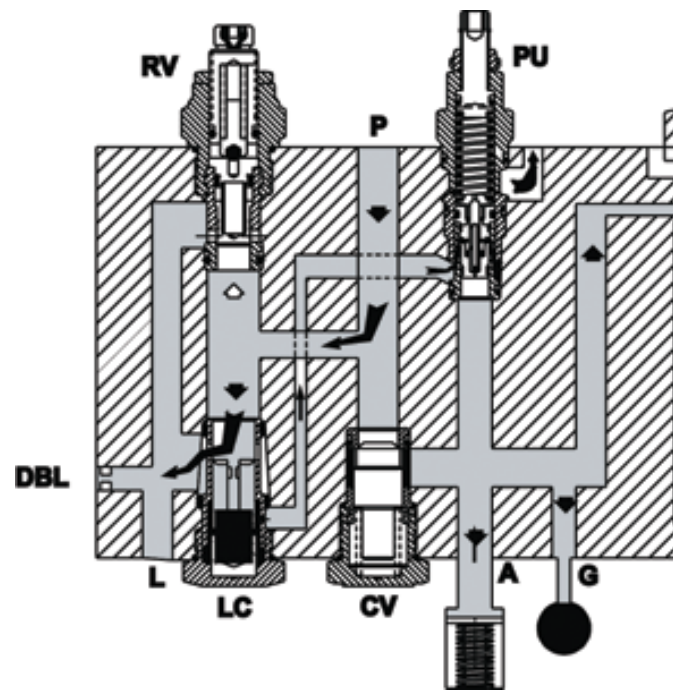

As the accumulator fills and the oil pressure in the control circuit increases, the oil pressure acting on the lower cavity of the PU cartridge also increases. When the pressure reaches the preset value, 400 PSI (2760 kPa), the small pilot spool is moved off its seat to allow a small amount of oil to pass through the cartridge to exit the valve at port AT. This oil flow signals the poppet inside PU to open the center cavity to the winch sump, also at port AT. The oil that was holding the relief poppet closed in the LC cartridge is now exhausted to the sump and the relief poppet opens to direct all of the oil from the pump to exit the valve through port T. The oil in the control circuit holds the check valve (CV) closed preventing a loss of stored oil in the accumulator. All the oil from the pump will continue to flow into port P, past the relief poppet in LC and out of the valve to the winch sump through port T until the relief poppet in LC closes.

Return to Charging

When the operator shifts the control lever to reel in, reel out or brake off, some of the oil stored in the accumulator will be used to apply the clutch and release the brake. The loss of oil from the accumulator will result in less pressure in the control circuit and port A. The differential pressure unloading valve spool will close with spring force. When PU closes, the oil in the center cavity can not escape to port TA and the pilot pressure increases in the passage leading to the spring cavity of the logic control cartridge, LC. This increase in pressure behind the spool causes the spool to shift and close the passage to the winch sump at port T. All the oil from the pump must now open the check valve CV, and refill the accumulator through port A and charge the control circuits.

The pressure maintenance system will cycle between “Charging” and “Unloading” every 30 seconds to more than ten minutes depending on PTO speed (pump flow) and control functions selected.

⚠ WARNING ⚠

Discharge accumulator oil supply before removing any hydraulic lines or servicing winch. Personal injury may result from sudden release of oil pressure. To discharge the accumulator, stop engine, slowly cycle power shift control handle into full Reel-In then Reel-Out positions a minimum of five (5) times.

Directional Control System

The directional control system consists of the following sub-assemblies:

CLV – Clutch Control Valve Cartridge

BRV – Brake Control Valve Cartridge

S1 & S2 – Shuttle valve assemblies (2)

The clutch control valve cartridge (CLV) contains a closed center, open port, spring centered spool valve. When pushed or pulled by the control cables, the clutch control spool will direct control oil pressure from the center port to apply either the Reel –in or Reel-out clutch and release the spring applied brake.

When the operator returns the control lever to the center, brake-on position, the spool moves to exhaust the control pressure from the clutch and brake ports to the winch sump. The spool traps the control oil pressure in the “closed” center cavity.

The brake control valve cartridge (BRV) contains a closed center, open port, spring centered, proportional spool valve. When pushed inward by the control cable to the brake-off position, control oil pressure is directed through a shuttle valve to release the spring applied brake. The

pressure sent to release the brake will increase steadily as the operator begins to move the lever from the center, brake-on position to the fully released position where a detent mechanism in the control lever will hold the BRV spool fully shifted.

When the control lever is returned to the center, brake-on position, springs will return the spool to the center position within the BRV cartridge to exhaust the control oil from the brake assembly and to seal off the control oil supply passage.

Two shuttle valves (S1 & S2), or double check valves are used in the circuits between the control cartridges (CLV & BRV) and the brake port B. The shuttle valves permit the brake to be released by three different control circuits; Reel-in, Reel-out and Brake-off.

When the check ball of the shuttle valve is seated by the force of the control oil pressure, it must seal tightly, for the back side of the ball will be open to sump through an unused circuit. If the ball does not seal tightly, due to contamination or wear, control oil pressure, needed for clutch application and brake release, will be lost and the clutch or brake could slip.

BRAKE ON

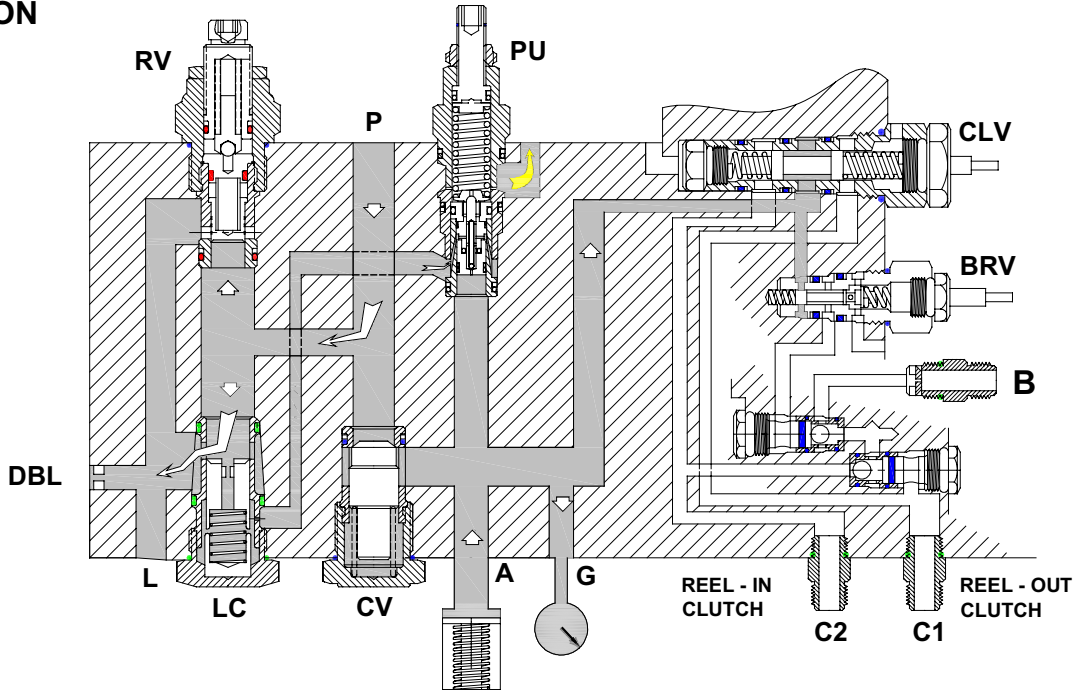

The operator's control lever is in the centered, brake-on, "neutral" position. Supply oil from the pump, flows through the filter and enters the valve at port P. The control valve is in the "Unloading" mode and all the oil from the pump flows through the logic control cartridge, LC and to the winch sump through port T. Most of the oil that flows out

of the valve through port T will pass through the brake assembly port F to cool and lubricate the brake discs. The check valve cartridge holds the control oil pressure stored in the accumulator and control passages in the control valve. No control oil is being used by the clutches or brake at this time.

BRAKE OFF

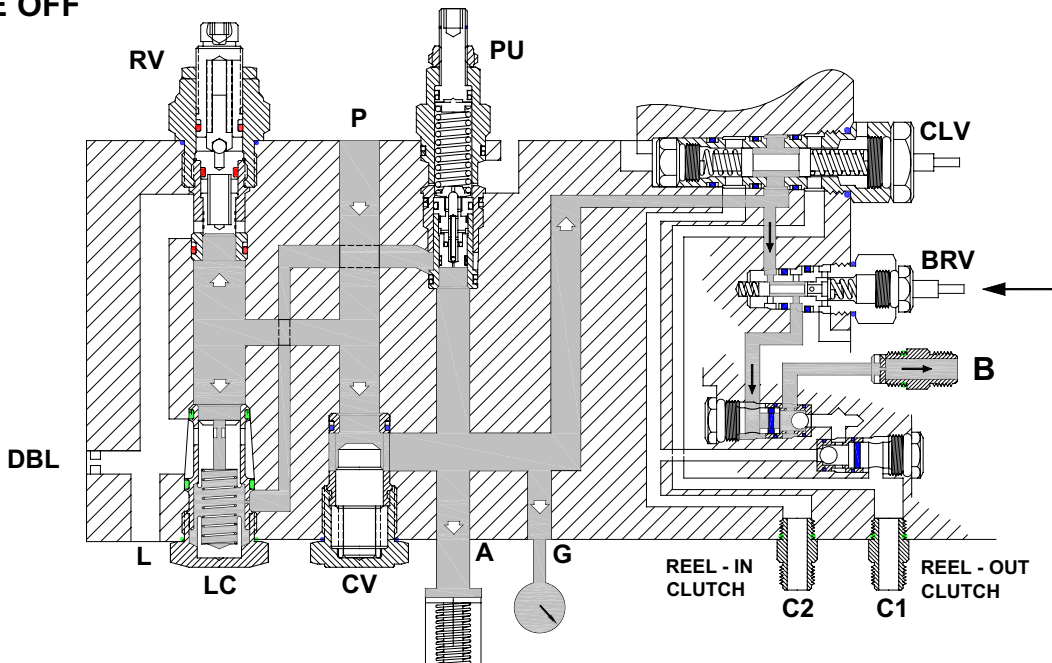

The winch cable is attached to a load and the operator needs to move the tractor away from the load. As the operator moves the control lever into the brake-off position, the control cable pushes against the spool of the proportional brake valve (BRV). The spool opens a path from the control oil supply passage toward the brake port B. The control oil pressure will push the shuttle valve

check ball onto a seat and flow through a metering orifice and out the valve housing through port B. The oil pressure acts on the piston of the brake assembly to overcome the spring force and allow the brake discs to turn freely. The BRV cartridge is proportional and will increase the brake release oil pressure as the control valve spool is pushed further into the cartridge.

The act of releasing the brake consumed some of the control oil stored in the accumulator and caused a momentary drop in pressure. This pressure drop signaled the differential pressure unloading valve (PU) to close which changes the pressure maintenance system from UNLOADING mode to CHARGING mode as previously described.

When the operator returns the control lever to the brake-on position, the brake control valve spool will spring center and exhaust the brake release oil pressure from the brake circuit. The spring applied brake will quickly apply to hold the load.

REEL-IN

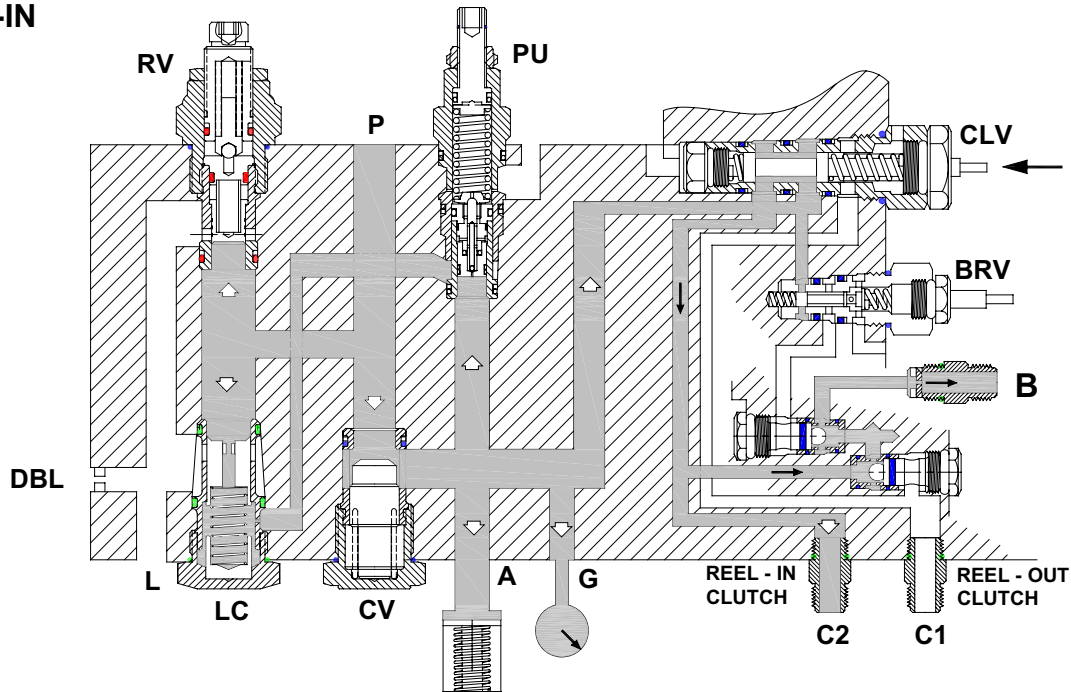

Pulling the winch control lever toward the operator has pushed the clutch control valve (CLV) spool inward. The CLV spool directs control oil from the center cavity toward the reel-in clutch. The control oil will shift shuttle valve S1 and S2 from the BRV side to the CLV side to release the brake through port B. The control oil pressure will then flow out of the valve through port C2 and on to the reel-in clutch. (The description given is for a four-shaft winch and CCW, PTO shaft rotation). A restrictor/check disc is installed between the valve housing and the hose adapter in port B. This restrictor controls the overlap or timing of the brake release compared with clutch application.

The act of applying the reel-in clutch and releasing the spring applied brake consumed some of the control oil stored in the accumulator and caused the momentary drop in control oil pressure. The pressure drop signaled the PU to change from UNLOADING to CHARGING mode.

When the operator returns the control lever to the brake-on position, the spring centered clutch control valve spool will return to the center position and exhaust the clutch application and brake release oil through port C2T. The spring applied brake will apply quickly to hold the load securely.

REEL-OUT

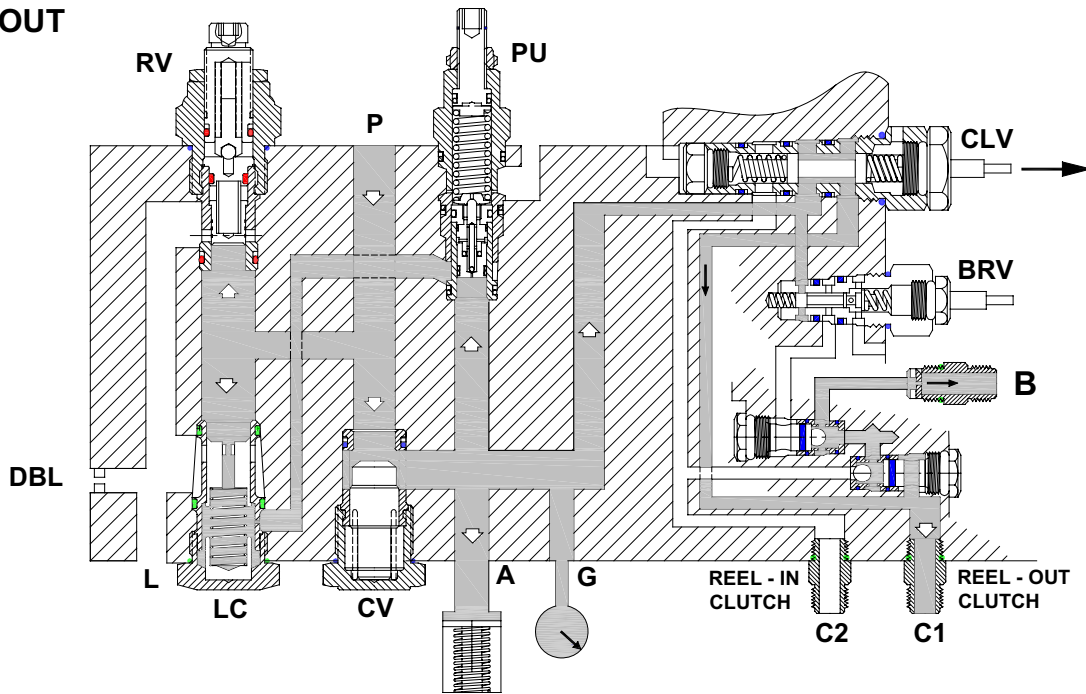

When the control lever is pushed away from the operator into the reel-out position, the spool of the CLV is pulled outward to direct control oil pressure from the center pressure cavity toward the reel-out clutch, port C1. Control oil pressure will flow through shuttle valve S1 and S2 to release the brake through port B to apply the reel-out clutch through port C1. (The description given is for a four-shaft winch and CCW, PTO shaft rotation). As described earlier, any loss of control oil pressure from the

stored supply in the accumulator will signal the pressure maintenance system to refill the accumulator and the control oil pressure to 320 - 400 PSI (2210 – 2760 kPa).

When the control lever returns to neutral, the oil holding the brake released and the reel-out clutch applied will be quickly exhausted through port C2. As the clutch releases, the brake applies to hold the load securely.

CONTROL VALVE REMOVAL

⚠ WARNING ⚠

Discharge accumulator oil supply before removing any hydraulic lines or servicing winch. Personal injury may result from sudden release of oil pressure. To discharge the accumulator, stop engine, slowly cycle power shift control handle into full Reel-In then Reel-Out positions a minimum of five (5) times.

Remove the right hand winch housing cover. Carefully tag and remove the oil lines from the control valve. Cap the ends of the hoses and the open adapters in the control valve to prevent the entry of contamination. Remove the clevis pins that attach the control cables to the control valve spools. Remove the capscrew securing the control valve to the winch case then remove the control valve from the winch case.

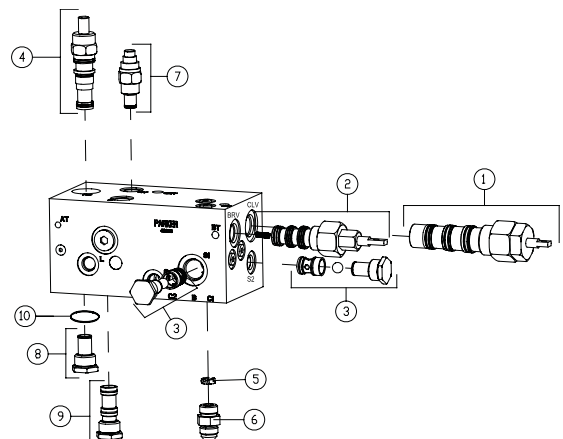
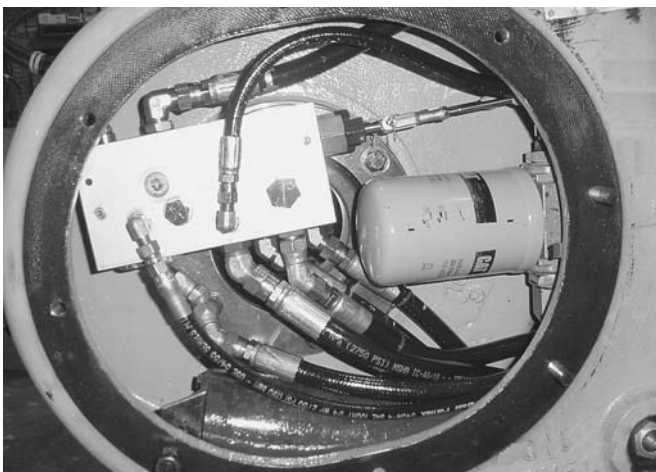

COMPONENT INSPECTION

Make certain work area is clean as cleanliness is of utmost importance when working on hydraulic equipment. If a control valve problem has been thoroughly diagnosed, complete valve disassembly and cleaning is recommended to ensure all components have been inspected and contaminants have been removed.

Clutch Control Valve (CLV) and Brake Control Valve (BRV) Cartridges

Turn the large hex counter-clockwise (CCW) to remove the cartridges from the control valve housing. Hold the cartridge and remove the spool end nut CCW to remove the spool from the valve body.

Carefully inspect the spool for scoring or excessive wear which may cause binding or leakage. If spools are damaged, the entire cartridge must be replaced.

Inspect the o-rings and back-up rings for cuts and flat-spots that would cause leakage. Cartridge seal kits are available through PACCAR Service Parts. Due to close tolerances, the seals are difficult to replace without damage. Wrap a small sheet of .005 in. (.13 mm) shim stock around the cartridge to provide a smooth ramp to slide seal rings into place.

Lubricate seals and the valve housing bore with winch lubricant and install the cartridges into the valve housing. To install the brake control valve cartridge in the housing, stand the valve on end with the spools facing up. Carefully install the small brake spool spring into the bore at the bottom of the housing cavity then install the cartridge into the housing.

Shuttle Valves (S1 & S2)

Remove the shuttle valve cartridges from the valve housing. The inner body will remain in the valve housing due to seal drag. Use external lock ring pliers to retrieve the inner body. Inspect the check ball seats in the outer and inner valve bodies. If there is any sign of rounding or flaring of the seat, the shuttle valve must be replaced. Inspect the o-rings and back-up rings for cuts or flat-spots that may cause leakage. Shuttle valve seal kits are available through PACCAR Service Parts.

Lubricate the seal rings with winch lubricant and install the check ball in the cavity between the inner and outer body. Install the shuttle valves into the valve housing.

Check Valve Cartridge (CV)

Remove the check valve cartridge from the bottom of the valve housing. Remove the inner valve section from the cap to inspect the condition of the check poppet and seats. If the seats are rounded or flared, the check valve cartridge must be replaced. Inspect the o-rings and back-up rings for cuts or flat spots that may result in leakage.

Replace the seal rings as required.

Differential Pressure Unloading (PU) and Relief Valve (RV) Cartridges

Remove the unloading and relief cartridges from the valve housing. These cartridges can not be disassembled. Inspect the condition of the o-rings and back-up rings for cuts or flat-spots that may cause leakage. Cartridge seal kits are available from PACCAR Service Parts. If there is any evidence of contamination damage to the cartridges, they must be replaced.

Logic Control Cartridge (LC)

Remove the cartridge from the bottom of the control valve housing. Remove the inner valve body from the outer body. Carefully inspect the condition of the spool and body for scoring or damage from contamination. If there are any signs of scoring, the cartridge must be replaced. Replace the seal rings as required.

If the entire control valve has been disassembled, be sure to install the restrictor/check disc into the valve housing above the hose adapter in the B port. The cross-cut side of the disc must face toward the valve housing.

CONTROL VALVE INSTALLATION & ADJUSTMENT

Place the control valve in the winch case opening and align the machined pocket on the back side of the valve with the special dowel bolt in the winch case. Apply non-hardening thread sealant to the long capscrew that secures the valve to the case. Install the capscrew and tighten it to 75 lb-ft (102 N-m) torque.

Install the hoses to the valve.

Make certain the operators control lever is in the center, neutral position. Install the control cables to the valve spools and secure with clevis and hitch pins. The clevis pins should slip easily into the bores of the yokes and spools without binding. The control valve spools are spring-centered. If any binding is observed, turn the cable adjusters on the front of the winch case in or out as needed until a "free pin" condition is achieved.

Install an accurate 0-600 PSI (0-5000 kPa) pressure gauge onto the gauge port quick-disconnect adapter, located next to the control cables on the right hand, front of the winch. Start the tractor and operate the engine at approximately 800 – 1000 RPM. The maximum pressure during the "charging" mode should peak at 390 – 410 PSI (2690 – 2830 kPa) when the valve changes to the "unloading" mode.



TIP: Place the control lever in brake-off to use some of the oil stored in the accumulator which will cause the control valve to cycle from "unloading" into "charging" so that peak pressure can be observed.

During normal operation, the control pressure will decay approximately 15-20% from the peak pressure then charge back up to 390 – 410 PSI when the valve cycles. If the maximum peak pressure needs adjustment, locate the differential pressure unloading (PU) cartridge on top of the control valve. Loosen the jam nut and, with a 3/16 in. hex key, turn the adjusting screw clock wise (CW) to increase peak pressure and counter-clock wise (CCW) to decrease peak pressure.

CAUTION

The control valve has several exhaust ports that will spray oil out toward the technician when the control valve is operated. Install the cover between tests or use a piece of cardboard to deflect the oil spray.

Stop the engine, discharge the stored oil pressure from the accumulator as described earlier and move the test gauge to the “B” port on the brake assembly. A -6 ORB adapter is needed.

Start the tractor engine and operate at approximately 800-1000 RPM. Move the control lever into the brake-off position and observe the brake release pressure at port “B” on the brake.

Adjust the control cable to achieve the highest pressure, approximately the same as the main system pressure, when the control lever is latched in the brake-off position. The pressure gauge **MUST** read 0 PSI (0 kPa) in the brake-on position.

CAUTION

If the brake release pressure does NOT return to 0 PSI (0 kPa) when the control lever is in the brake-on position, the brake may slip when holding a heavy load which may result in loss of load control, property damage, injury or death. This condition indicates that the control cable is not adjusted correctly and may also result in excessive heat and accelerated wear of brake and hydraulic components.

Place the control lever in brake-on position, remove the pressure gauge from the brake test port and install the plug.

Operate the engine at approximately 1200 RPM for five minutes to recharge the hydraulic system. Check for proper operation of all functions and check for leaks. Install the access cover and tighten the eight fasteners to 75 lb-ft (102 N-m) torque.

ACCUMULATOR SERVICE

The accumulator stores oil at system pressure. The primary function of the accumulator is to cushion pressure surges in the hydraulic system and aid in brake release and clutch application. The accumulator also stores enough oil for the operator to release the brake when the tractor PTO is stalled or the tractor engine stops.

WARNING

Discharge accumulator oil supply before removing any hydraulic lines or servicing winch. Personal injury may result from sudden release of oil pressure. To discharge the accumulator, stop engine, slowly cycle power shift control handle into full Reel-In then Reel-Out positions a minimum of five (5) times.

The spring-type accumulator **DOES NOT** require any periodic recharging or servicing.

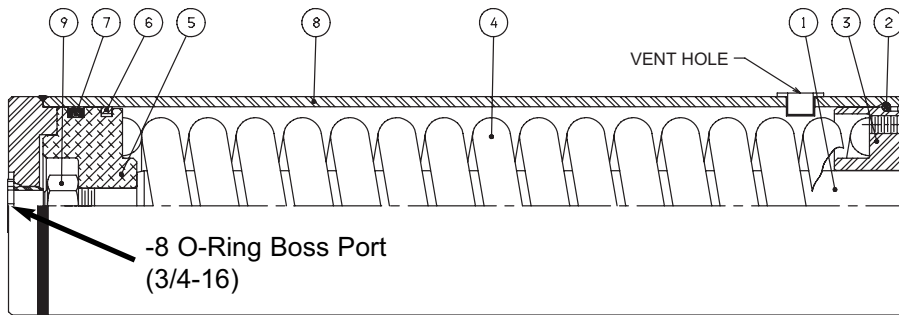

Rod extension at no pressure is 0.06 in. (1.5 mm).

Rod extension at 400 psi (2760 kPa) is approximately 1.57 in. (40 mm)

ITEM	DESCRIPTION	QTY.
1	Rod	1
2	Retaining Ring	1
3	Rod Guide	1
4	Spring	1
5	Piston	1
6	Cast Iron Piston Ring	1
7	Seal Assembly	1
8	Tube Assembly	1
9	Nut	1

⚠ WARNING ⚠

Discharge accumulator oil supply before removing any hydraulic lines or servicing winch. Personal injury may result from sudden release of oil pressure. To discharge the accumulator, stop engine, slowly cycle power shift control handle into full Reel-In then Reel-Out positions a minimum of five (5) times.

PISTON SEAL TEST PROCEDURE

1. If the accumulator is installed in the winch case, remove the accumulator hose from the "A" port of the control valve. The accumulator may then be tested in the winch case.
2. Connect a hand pump with accurate 0-600 psi (0-4137 kPa) gauge and shut-off valve to the accumulator. Apply 400 psi (2758 kPa) to the accumulator. Close shut-off valve securely. Measure rod extension beyond rod guide. If rod extension decreases more than 1/8 in. (3 mm) in one minute, the accumulator should be disassembled and new seals installed.

⚠ WARNING ⚠

2,000 lb (900 kg) spring preload! ALWAYS use a press for disassembly per service instructions given below. If rod guide removal is attempted without using a press, property damage, injury or death may result.

If piston seal ring inspection or replacement are required, carefully follow the procedure listed below.

1. Secure the accumulator tube in a hydraulic press in such a manner to prevent side movement.
2. With a tubular mandrel, press rod guide (3) approximately 1/2 in. (13 mm) into tube (8) to provide access to retaining ring (2). Carefully remove retaining ring (2) from the groove in the tube. Discard retaining ring.
3. Slowly release pressure on the press and remove rod guide (3), spring (4) and piston/rod assembly.

i TIP: The cast iron piston ring (6) will attempt to expand into the retaining ring groove when the piston is removed from the tube. To reduce the chances of this happening, pack the groove with heavy grease and withdraw the piston rod assembly quickly past the groove.

4. Inspect or replace piston seals (6 & 7) as required. While the accumulator is disassembled, check the piston retaining nut (9). It should be tightened to 120 lb•ft (163 N•m) torque.
5. Lubricate tube and piston seals with winch lubricant. Install an automotive type piston ring compressor around the piston making certain the step cut piston ring is properly compressed.
6. Press piston into tube and push to bottom of tube. Install spring and rod guide.
7. With the tube secured in a press, press rod guide into tube approximately 1/2 in. (13 mm) below the outer edge of the tube. Install a **new** retaining ring (2) securely into the groove in the tube.
8. Slowly release pressure on the press. Observe that the rod guide has fully seated the retaining ring into the groove.
9. Retest piston seals to make certain seals were not damaged during installation.